

### Introduction

The timing of the rising edge of active video with respect to the falling edge of the horizontal sync tip is an important parameter in an analog composite video signal. It affects the screen position of the image on the television monitor. If it's too large, then the image is shifted right. If too small, the image goes left.

The use of digital video encoders provides great flexibility in adjusting the timing, and thus the position, of the image. At the same time, it adds some confusion since the standard definitions of digital and analog video do not match. The BT.601 recommendation for digital video defines an active region that's larger than the active region in BT.470 analog video.

This Tech Brief describes the differences between the BT.601 and BT.470 line timing and shows how Intersil digital video encoders (HMP8154, HMP8156A, HMP8170-73, and HMP8190-91) meet the timing requirements. This Tech Brief also describes the timing differences found for the master and slave modes for blanking and sync that the Intersil encoders provide.

### Digital Overscan

Most common definitions of digital video data are based on ITU-R BT.601. The BT.601 recommendation specifies the data sampling rates shown in Table 1. The table shows the active and blanked portions of each line in terms of samples and also microseconds.

TABLE 1. BT.601 DIGITAL VIDEO LINE TIMING

VIDEO STANDARD	TOTAL SAMPLES	ACTIVE SAMPLES	BLANKED SAMPLES
NTSC 525/60	858 (63.56μs)	720 (53.33μs)	138 (10.22μs)
PAL 625/50	864 (64.00μs)	720 (53.33μs)	144 (10.67μs)

NOTE: Sampling rate is 13.5MHz for all standards.

The ITU-R BT.470 defines the line timing for analog video signals. The blanking and active regions it recommends are shown in Table 2.

Comparing Tables 1 and 2, we see that the active region of digital video is longer than that of the analog video. The active digital samples overscan the analog active region.

TABLE 2. BT.470 ANALOG VIDEO LINE TIMING

VIDEO STANDARD	TOTAL LINE TIME	ACTIVE TIME	BLANKED TIME
NTSC 525/60	63.5μs (15.734kHz)	52.6 ± 0.2μs	10.9 ± 0.2μs
PAL 625/50	64.0μs (15.625kHz)	52.0 ± 0.3μs	12.0 ± 0.3μs

The overscanned portions of the line in the digital data allow for slight errors in any digital processing without losing any of the sampled active analog video. Typical errors include sampling offsets, filter pre-load, or pipeline delay mismatch.

Since the overscanned samples extend into the front and back porch regions of the analog video, they are known as front overscan (FOS) and back overscan (BOS). BT.601 specifies the number of samples from the end of the digital active video (EAV) to the 50% point of the horizontal sync tip. This positions the digital data with respect to the analog line and defines the number of FOS and BOS samples. The values are shown in Table 3.

TABLE 3. DIGITAL OVERSCAN AMOUNTS

VIDEO STANDARD	DIGITAL END TO ANALOG SYNC	FOS SAMPLES	BOS SAMPLES
NTSC 525/60	16 (1.19μs)	4 (0.30μs)	5 (0.37μs)
PAL 625/50	12 (0.89μs)	8 (0.59μs)	10 (0.74μs)

NOTE: Sampling rate is 13.5MHz for all standards.

The values shown in the tables above are summarized in Figure 1. The sample counts and times shown in the figure are nominal since some measurements are made from the 50% point of the start or end of the analog video while others are measured from the 4 IRE point.

### H Sync and Blank Timing

The Intersil digital encoders provide a very flexible video control interface. The horizontal and vertical syncs may be input or output, the blanking signal may be input or output, and all may be active low or active high. In addition, the timing of blank with respect to H sync is programmable.

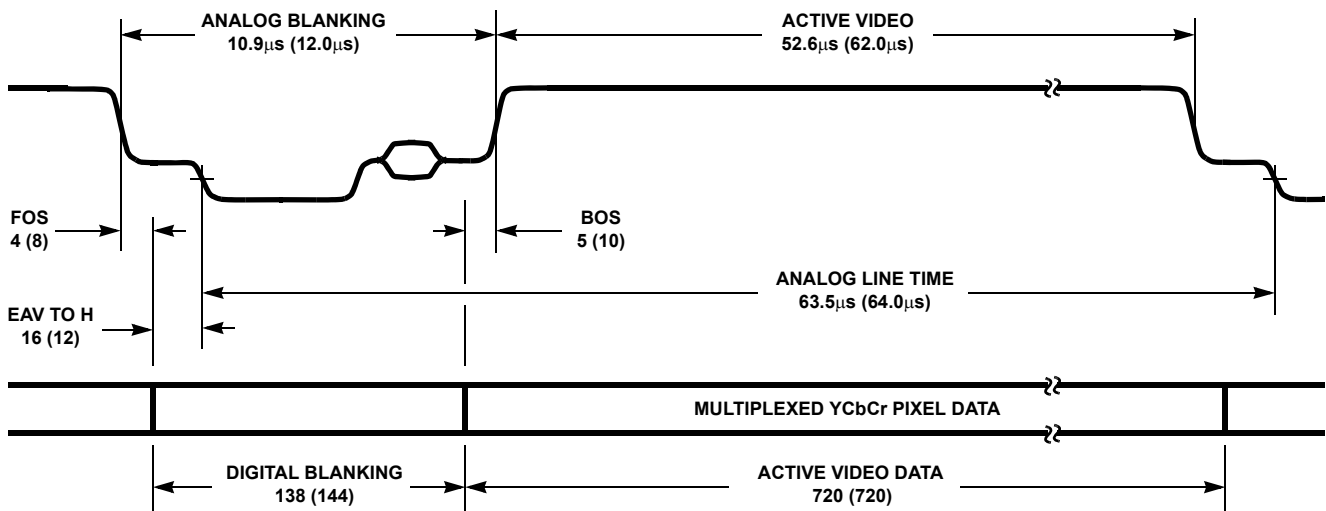

FIGURE 1. BT.601 AND BT.470 TIMING COMPARISON AND SUMMARY 525/60 (625/50)

Although the timing of H sync and blank is programmable with respect to each other, the timing relationship between the digital control signals and the output video is fixed when generating standard video waveforms. The four important timing parameters are shown in Figure 2. Note that the figure shows the BT.601 digital blanking and the longer BT.470 analog blanking intervals.

Blank delay is the number of clocks from the edge of blank to the end or start of video. Since the encoder provides edge rate control, the start (end) of video will appear to be slightly after (before) the expected time. The blank delay reflects the data pipeline delay through the part. The pipeline delay is constant throughout the line.

Sync delay is the number of clocks from the active edge of the signal at the HSYNC I/O pin and the 50% point of the falling edge of the analog sync tip.

The end of blank to H sync and H sync to start of blank measurements position the blanking signal around H sync and thus the active video within the line time.

The timing of the video with respect to the control signals depends on their I/O directions. There are four combinations of sync and blank I/O directions: both input, both output, or mixed input and output. The timing of the output video with respect to the control signals is summarized in Table 4.

When the values from Table 4 are combined with Figure 2, the resulting waveforms show the signal timing required to generate standard NTSC video. (This assumes that the overscanned samples in the digital data are input as black pixels.)

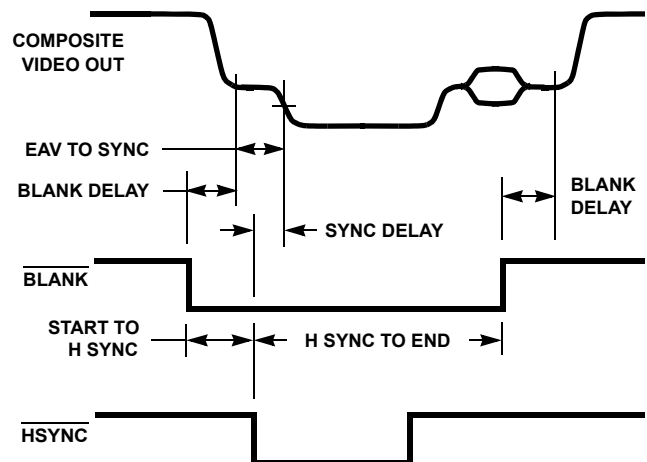

FIGURE 2. H SYNC, BLANK, AND VIDEO TIMING

Because of the pipe line delays through the encoder for sync and data, the signals do not line up exactly as shown in Figure 1. However, the difference between the delays is such that the output video timing is correct. For example, the digital blanking interval is given by the sum of the blanking start to H sync and H sync to end times or 276 clocks. The sum is the same as the 138 BT.601 samples. Also, the blanking start to H sync time plus the sync delay less the blank delay is the same as the end of active video to sync time, or 32 clocks (16 samples).

## Summary

This Tech Brief has shown the timing differences between digital video input and analog composite video output per the ITU recommendations BT.601 and BT.470. This Tech Brief has

also shown the H sync and blanking waveforms required by Intersil encoders in order to generate standard video.

**TABLE 4. H SYNC, BLANK, AND VIDEO TIMING DELAY**

MODE			DELAYS (NOTES 1, 2)							
NAME	SYNC	BLANK	SYNC (NOTE 3)		BLANK (NOTE 4)		START TO H SYNC (NOTE 5)		H SYNC TO END (NOTE 5)	
			T	μs	T	μs	T	μs	T	μs
Master	Output	Output	6.2	0.23	28	1.04	55	2.04	221	8.19
Mixed Mode A	Output	Input	6.2	0.23	26	0.96	53	1.96	223	8.26
Mixed Mode B	Input	Output	15.1	0.56	28	1.04	45	1.67	231	8.56
HV Slave	Input	Input	35.1	1.30	26	0.96	23	0.85	253	9.37
BT.656 Slave (Note 6)	Output	Output								

NOTES:

1. Delay times were measured in microseconds; the number of clocks were calculated. The values are given in pixel clock (CLK2) cycles and in microseconds with an uncertainty of  $\pm 0.01\mu\text{s}$  or about one 27MHz clock cycle.
2. Delay times are given for 8-bit YCbCr mode input. The delays for other input modes are similar but may include extra pixel clock (CLK2) cycles since the inputs are only registered when the input qualifier (CLK) is low.
3. The sync delay time includes fractions of a clock since it is measured with respect to the 50% point of the analog sync tip.
4. The pipe line delays for blank differ by one clock cycle for blank input and output. The second clock cycle shown in the table values occurs since the pixel data must arrive at the part at the same time in all cases. However, when blank is an output, the data follows one clock after the encoder generates blank. When blank is an input, it arrives during the same clock cycle as the data.
5. Delay times for blank w.r.t. H sync are shown for NTSC 525/60 line rates. The net delays for PAL are different but the relative positions of end and start are the same.
6. When BT.656 mode is selected, the video timing is derived from the input. The slaved encoder also outputs the timing signals derived from the input data stream.

## Notice

1. Descriptions of circuits, software and other related information in this document are provided only to illustrate the operation of semiconductor products and application examples. You are fully responsible for the incorporation or any other use of the circuits, software, and information in the design of your product or system. Renesas Electronics disclaims any and all liability for any losses and damages incurred by you or third parties arising from the use of these circuits, software, or information.
2. Renesas Electronics hereby expressly disclaims any warranties against and liability for infringement or any other claims involving patents, copyrights, or other intellectual property rights of third parties, by or arising from the use of Renesas Electronics products or technical information described in this document, including but not limited to, the product data, drawings, charts, programs, algorithms, and application examples.
3. No license, express, implied or otherwise, is granted hereby under any patents, copyrights or other intellectual property rights of Renesas Electronics or others.
4. You shall not alter, modify, copy, or reverse engineer any Renesas Electronics product, whether in whole or in part. Renesas Electronics disclaims any and all liability for any losses or damages incurred by you or third parties arising from such alteration, modification, copying or reverse engineering.
5. Renesas Electronics products are classified according to the following two quality grades: "Standard" and "High Quality". The intended applications for each Renesas Electronics product depends on the product's quality grade, as indicated below.  
"Standard": Computers; office equipment; communications equipment; test and measurement equipment; audio and visual equipment; home electronic appliances; machine tools; personal electronic equipment; industrial robots; etc.  
"High Quality": Transportation equipment (automobiles, trains, ships, etc.); traffic control (traffic lights); large-scale communication equipment; key financial terminal systems; safety control equipment; etc.  
Unless expressly designated as a high reliability product or a product for harsh environments in a Renesas Electronics data sheet or other Renesas Electronics document, Renesas Electronics products are not intended or authorized for use in products or systems that may pose a direct threat to human life or bodily injury (artificial life support devices or systems; surgical implantations; etc.), or may cause serious property damage (space system; undersea repeaters; nuclear power control systems; aircraft control systems; key plant systems; military equipment; etc.). Renesas Electronics disclaims any and all liability for any damages or losses incurred by you or any third parties arising from the use of any Renesas Electronics product that is inconsistent with any Renesas Electronics data sheet, user's manual or other Renesas Electronics document.
6. When using Renesas Electronics products, refer to the latest product information (data sheets, user's manuals, application notes, "General Notes for Handling and Using Semiconductor Devices" in the reliability handbook, etc.), and ensure that usage conditions are within the ranges specified by Renesas Electronics with respect to maximum ratings, operating power supply voltage range, heat dissipation characteristics, installation, etc. Renesas Electronics disclaims any and all liability for any malfunctions, failure or accident arising out of the use of Renesas Electronics products outside of such specified ranges.
7. Although Renesas Electronics endeavors to improve the quality and reliability of Renesas Electronics products, semiconductor products have specific characteristics, such as the occurrence of failure at a certain rate and malfunctions under certain use conditions. Unless designated as a high reliability product or a product for harsh environments in a Renesas Electronics data sheet or other Renesas Electronics document, Renesas Electronics products are not subject to radiation resistance design. You are responsible for implementing safety measures to guard against the possibility of bodily injury, injury or damage caused by fire, and/or danger to the public in the event of a failure or malfunction of Renesas Electronics products, such as safety design for hardware and software, including but not limited to redundancy, fire control and malfunction prevention, appropriate treatment for aging degradation or any other appropriate measures. Because the evaluation of microcomputer software alone is very difficult and impractical, you are responsible for evaluating the safety of the final products or systems manufactured by you.
8. Please contact a Renesas Electronics sales office for details as to environmental matters such as the environmental compatibility of each Renesas Electronics product. You are responsible for carefully and sufficiently investigating applicable laws and regulations that regulate the inclusion or use of controlled substances, including without limitation, the EU RoHS Directive, and using Renesas Electronics products in compliance with all these applicable laws and regulations. Renesas Electronics disclaims any and all liability for damages or losses occurring as a result of your noncompliance with applicable laws and regulations.
9. Renesas Electronics products and technologies shall not be used for or incorporated into any products or systems whose manufacture, use, or sale is prohibited under any applicable domestic or foreign laws or regulations. You shall comply with any applicable export control laws and regulations promulgated and administered by the governments of any countries asserting jurisdiction over the parties or transactions.
10. It is the responsibility of the buyer or distributor of Renesas Electronics products, or any other party who distributes, disposes of, or otherwise sells or transfers the product to a third party, to notify such third party in advance of the contents and conditions set forth in this document.
11. This document shall not be reprinted, reproduced or duplicated in any form, in whole or in part, without prior written consent of Renesas Electronics.
12. Please contact a Renesas Electronics sales office if you have any questions regarding the information contained in this document or Renesas Electronics products.  
(Note 1) "Renesas Electronics" as used in this document means Renesas Electronics Corporation and also includes its directly or indirectly controlled subsidiaries.  
(Note 2) "Renesas Electronics product(s)" means any product developed or manufactured by or for Renesas Electronics.

(Rev.4.0-1 November 2017)



### SALES OFFICES

Renesas Electronics Corporation

<http://www.renesas.com>

Refer to "<http://www.renesas.com/>" for the latest and detailed information.

**Renesas Electronics America Inc.**  
1001 Murphy Ranch Road, Milpitas, CA 95035, U.S.A.  
Tel: +1-408-432-8888, Fax: +1-408-434-5351

**Renesas Electronics Canada Limited**  
9251 Yonge Street, Suite 8309 Richmond Hill, Ontario Canada L4C 9T3  
Tel: +1-905-237-2004

**Renesas Electronics Europe Limited**  
Dukes Meadow, Millboard Road, Bourne End, Buckinghamshire, SL8 5FH, U.K  
Tel: +44-1628-651-700, Fax: +44-1628-651-804

**Renesas Electronics Europe GmbH**  
Arcadiastrasse 10, 40472 Düsseldorf, Germany  
Tel: +49-211-6503-0, Fax: +49-211-6503-1327

**Renesas Electronics (China) Co., Ltd.**  
Room 1709 Quantum Plaza, No.27 ZhichunLu, Haidian District, Beijing, 100191 P. R. China  
Tel: +86-10-8235-1155, Fax: +86-10-8235-7679

**Renesas Electronics (Shanghai) Co., Ltd.**  
Unit 301, Tower A, Central Towers, 555 Langao Road, Putuo District, Shanghai, 200333 P. R. China  
Tel: +86-21-2226-0888, Fax: +86-21-2226-0999

**Renesas Electronics Hong Kong Limited**  
Unit 1601-1611, 16/F., Tower 2, Grand Century Place, 193 Prince Edward Road West, Mongkok, Kowloon, Hong Kong  
Tel: +852-2265-6688, Fax: +852-2886-9022

**Renesas Electronics Taiwan Co., Ltd.**  
13F, No. 363, Fu Shing North Road, Taipei 10543, Taiwan  
Tel: +886-2-8175-9600, Fax: +886-2-8175-9670

**Renesas Electronics Singapore Pte. Ltd.**  
80 Bendemeer Road, Unit #06-02 Hyflux Innovation Centre, Singapore 339949  
Tel: +65-6213-0200, Fax: +65-6213-0300

**Renesas Electronics Malaysia Sdn.Bhd.**  
Unit 1207, Block B, Menara Amcorp, Amcorp Trade Centre, No. 18, Jln Persiaran Barat, 46050 Petaling Jaya, Selangor Darul Ehsan, Malaysia  
Tel: +60-3-7955-9390, Fax: +60-3-7955-9510

**Renesas Electronics India Pvt. Ltd.**  
No.777C, 100 Feet Road, HAL 2nd Stage, Indiranagar, Bangalore 560 038, India  
Tel: +91-80-67208700, Fax: +91-80-67208777

**Renesas Electronics Korea Co., Ltd.**  
17F, KAMCO Yangjae Tower, 262, Gangnam-daero, Gangnam-gu, Seoul, 06265 Korea  
Tel: +82-2-558-3737, Fax: +82-2-558-5338