

Choosing and Using Bypass Capacitors

Introduction

Bypass capacitors are found in every working piece of electronic equipment. Most engineers know that systems, circuits, and individual chips need to be bypassed. The methods for choosing bypass capacitors typically follow decisions of tradition instead of optimizing for any particular circuit. This application note aims to bring the design aspect back to this seemingly simple component. After discussing the motivation for using bypass caps, we form a vocabulary around the basics; equivalent circuit, dielectrics and types of available capacitors.

The next step is identifying the primary function and environment of the bypass capacitor. Circuits that exhibit large current spikes have different bypassing needs than ones that solely operate at high frequencies. A few special options are discussed, like scaling multiple bypass capacitors, as well as the importance of board layout.

Finally, we present four application examples. These represent circuits with high and low currents as well as those with high and low frequencies.

Motivation

It's far too common (and quite distressing) to breadboard a circuit in an ideal configuration; only to find that it doesn't work well or it doesn't work at all (Figure 1). Noise may have coupled into the circuit from the power supply, internal IC circuitry, or nearby IC. Wires and board connections act like antennas and power supply levels change with current draw.

Taking a look at the power supply pin on the oscilloscope shows the following result (Figure 2).

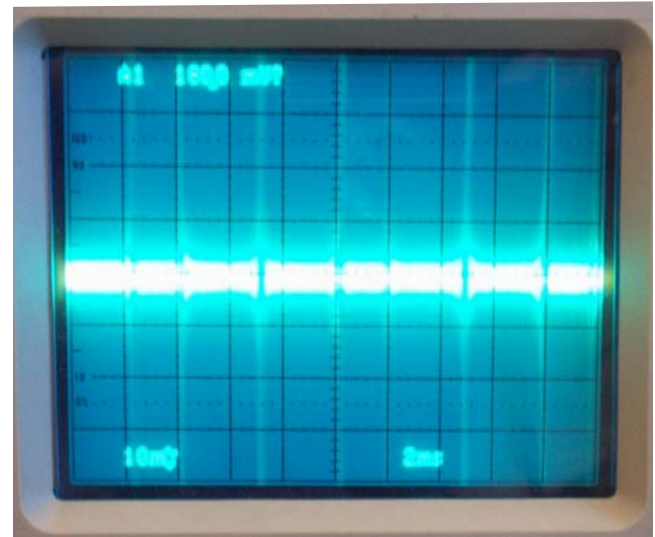

FIGURE 2. OSCILLOSCOPE VIEW OF DC POWER SUPPLY PIN ON NON-INVERTING AMPLIFIER

As one can see, there is a lot of high frequency noise displacing the DC level (approximately 10mV_{p,p}). Then, far more pronounced, there are regular spikes in excess of 50mV. Since power supplies are assumed to be stable (constant DC voltage), any perturbations will couple directly into the circuit and get to the output depending on the PSRR.

The first line of defense against unwanted perturbations on the power supply is the bypass capacitor. A bypass capacitor eliminates voltage droops on the power supply by storing electric charge to be released when a voltage spike occurs. It also provides this service at a wide range of frequencies by creating a low-impedance path to ground for the power supply.

We have four questions to answer before grabbing the closest capacitor:

1. What size bypass capacitor do we need?
2. Where do we place the bypass capacitor for maximum effect?
3. What type of bypass capacitor will work best/adequately in our circuit/system?
4. And a hidden fourth question—what type of package do I need to choose for my bypass capacitor? (which will depend on the size needed, the board area available, and type of capacitor chosen)

The simplest question to answer is #2, placement. A bypass capacitor should be placed as close as possible to the power supply pin of each chip. Any extra distance translates into additional series inductance, which lowers the self-resonant frequency (useful bandwidth) of the bypass capacitor.

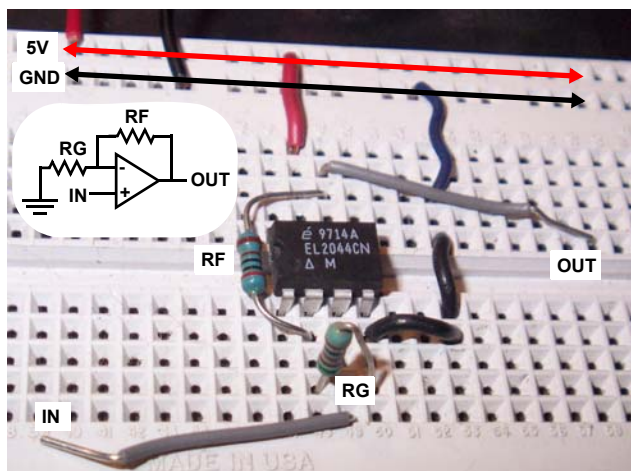

FIGURE 1. BREADBOARDED NON-INVERTING AMPLIFIER CONFIGURATION ($A_v = 2$)

Application Note 1325

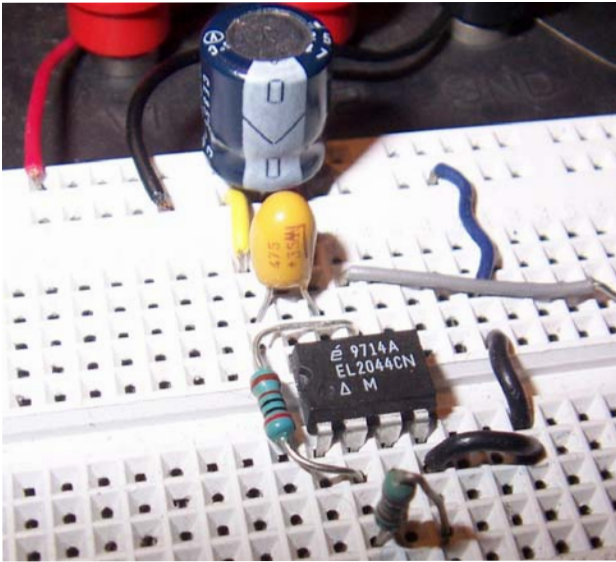

FIGURE 3. BREADBOARD CIRCUIT OF NON-INVERTING AMPLIFIER WITH BYPASS CAPACITORS

The effect of the bypass capacitor on the output of the non-inverting amplifier can be seen in Figure 4.

Further improvements in dealing with the placement and routing of the bypass capacitor will involve discussion of printed circuit board design—the topic of our next in-depth discussion.

The other three questions (about capacitor size, type, and package choice) are the heart of this discussion. These topics will be discussed in detail after first reviewing capacitor basics.

Capacitor Basics

The classic definition of a capacitor is two conductive plates separated by a dielectric material. As charge collects on the plates, an electric field builds across the dielectric. The amount of charge needed to create a certain potential between the plates is referred to as capacitance and is measured in Farads. The capacitance can also be measured by the dimensions of the plates and quality of the dielectric (Figure 5, Equation 1). Capacitance increases as the area of the plates increases since more charge can be stored as the potential is created. The distance between the plates dictates the attraction between charges stored on them. As the distance increases, the interaction is decreased, and therefore so is the capacitance. This discussion also relates the relationship shown in Figure 5, Equation 2.

The last of the basic equations involves current. By definition, current is the movement of charge (Figure 5, Equation 3). Therefore, there can only be movement of charge when the voltage (potential between the plates) is changing. In other words, if the voltage is constant, the charge forming it must also be constant; so no current is flowing.

In summary, the size of a capacitor has a direct effect on its ability to store charge. The second determining factor of capacitance is the quality of the dielectric.

Dielectrics

The dielectric is the material between the two conductors forming a capacitor. It has a high impedance and does not allow significant DC current to flow from one plate to the other. Different materials used as a dielectric have varying amounts of temperature stability, breakdown voltages and loss coefficients. The materials in Table 1 are accompanied by their dielectric constant (ϵ), which is the coefficient that directly relates to the capacitance of a structure through Equation 1 in Figure 5.

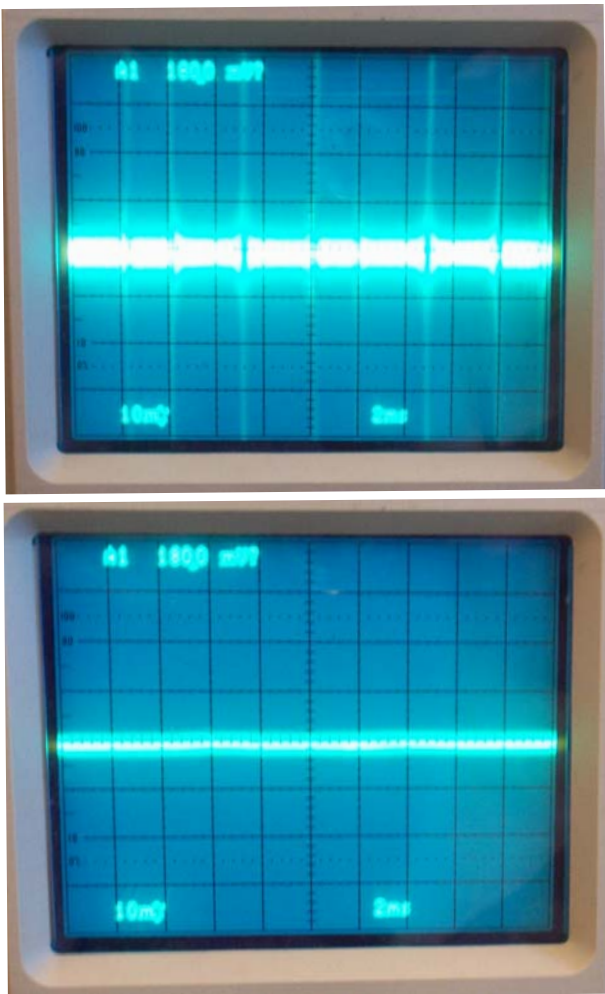

FIGURE 4. OUTPUT OF NON-INVERTING AMPLIFIER SHOWN IN FIGURE 3 WITHOUT BYPASSING (TOP) AND WITH BYPASSING (BOTTOM).

Application Note 1325

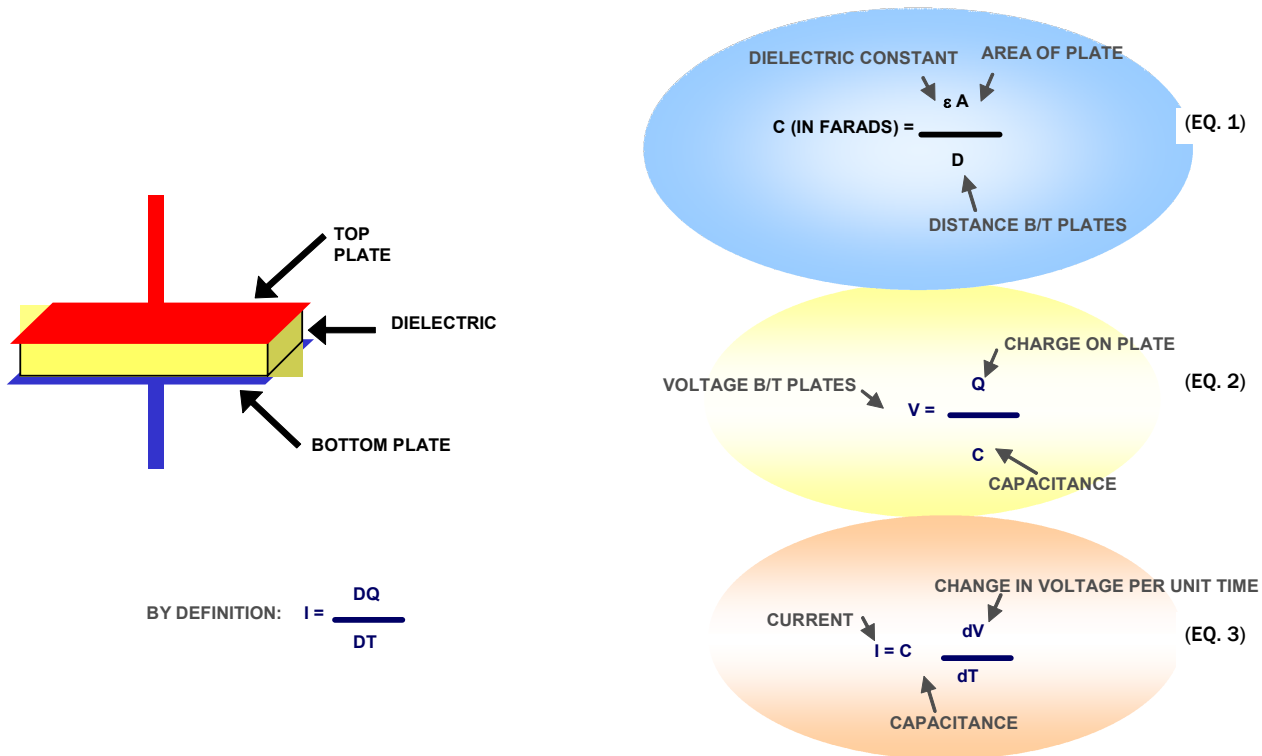

FIGURE 5. CAPACITOR STRUCTURE AND BASIC EQUATIONS

Equivalent Circuit Model

Once the structure is understood, the next logical step is creating an equivalent circuit model to use in simulation. The equivalent circuit model is shown in Figure 6. The main component, the capacitance, has a leakage resistance in parallel with it to represent any losses through the dielectric. In series with that RC pair is another resistive term in addition to an inductive term. These two values (ESR and ESL) represent the entire amount of DC and frequency dependent losses of the capacitive structure. Again, capacitor type and structure will dictate the values of these parasitic components.

FIGURE 6. EQUIVALENT CIRCUIT MODEL WITH COMPONENT DESCRIPTION

ABBREVIATION	EXPLANATION	SOURCE AND DETAILS
ESR	Equivalent Series Resistance	Wire and connections to the plate Produces heat
ESL	Equivalent Series Inductance	Depends on package type Surface mount better Smaller SMD better
RLEAK	Leakage Resistance	Type of dielectric

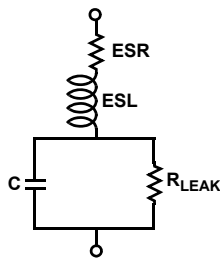







TABLE 1. EXAMPLES OF DIELECTRIC MATERIALS AND THEIR DIELECTRIC CONSTANTS

DIELECTRIC CONSTANT OF MATERIALS	
Air	1.00
Alsimag 196	5.70
Bakelite	4.90
Cellulose	3.70
Fiber	6.00
Formica	1.75
Glass	7.75
Mica	5.10
Mycalex	7.10
Paper	3.00
Plexiglass	2.80
Polyethylene	2.30
Polystyrene	2.60
Porcelain	5.57
Pyrex	4.00
Quartz	3.80
Steatite	5.80
Teflon	2.10

Application Note 1325

TABLE 2. COMMON CAPACITOR SPECIFICATIONS AND TRADE-OFFS

TYPE	PIC	CAP RANGE	ESR	LEAKAGE	VOLTAGE RATING	TEMP RANGE	GENERAL NOTES
Ceramic		pF to μ F	Low	Medium	High	-55 °C to +125 °C	Multipurpose Cheap
Mica (silver mica)		pF to nF	Low 0.01 Ω to 0.1 Ω	Low	High	-55 °C to +125 °C	For RF Filters Expensive Very Stable
Plastic Film (polyethylene polystyrene)		few μ Fs	Medium	Medium	High	Varies	For Low Frequency Inexpensive
Tantalum		μ Fs	High 0.5 Ω to 5.0 Ω	Low	Lowest	-55 °C to +125 °C	Expensive Nonlinear (bad for audio)
OSCON		μ Fs	Low 0.01 Ω to 0.5 Ω	Low	Low	-55 °C to +105 °C	Best Quality Highest Price
Aluminum Electrolytic		High μ Fs	High 0.05 Ω to 2.0 Ω	Medium	Low		For Low to Med. Frequencies Inexpensive Hold Charge for Long Time - Not for Production Test

Common Types of Capacitors and Trade-offs

As described in the previous sections, the materials and structure of a capacitor will dictate its attributes, like parasitics, temperature stability, maximum voltage, linearity, cost and size. A summary of the most popular capacitors available in surface mount packages is given in Table 2.

Ceramic capacitors are the most common capacitor type since they are inexpensive, offer a wide range of values, and provide solid performance. Tantalum, OSCON, and Aluminum Electrolytic capacitors are all polarized (specifically to be used as a bypass capacitor). Tantalum found their niche in low-voltage systems. Aluminum electrolytic capacitors are a common choice for low-to-medium frequency systems, but not switching circuits (they hold their charge too well which doesn't suit them for the rapid cycling of production testing). OSCON is a special capacitor type developed to provide low parasitics, wide frequency range and full temperature range (the best quality available for the highest price tag). If you have the budget, these capacitors will provide quality bypass for any circuit.

Mica and Plastic Film capacitors are included for completeness. Their primary use is in filter design instead of bypass.

Since ceramic capacitors are the most widely used bypass capacitors, it is useful to look at the options available in purchasing. As expected, ceramic caps are available in a wide range of values and in a wide variety of packages. Within these parameters, there are further choices which will determine the final price. An example is set forth in Table 3. In a recent bill of materials, the capacitors were labeled as "X7R". The X and 7 set the widest temperature range. The final letter "R" reports the tolerance of that capacitor over the temperature range. In this case, there would only be a 15% change in capacitor vs temperature. A wider temperature range and tighter tolerance earn higher price tags.

Application Note 1325

TABLE 3. CLASSIFICATION OF CERAMIC CAPACITOR OPTIONS

CERAMIC (EIA CLASS II) CAPACITOR CODE					
LETTER SYMBOL	LOW TEMP. REQUIREMENT	NUMBER SYMBOL	HIGH TEMP. REQUIREMENT	LETTER SYMBOL	MAX. ΔC OVER ΔT
Z	+10 °C	2	+45 °C	A	±1.0%
		4		B	±1.5%
Y	-30 °C	5	+65 °C	C	±2.2%
		6		D	±3.3%
X	-55 °C	7	+85 °C	E	±4.7%
				F	±7.5%
				P	±10.0%
				R	±15.0%
			+105 °C	S	±22.0 -
				T	±22.0 -
				U	±22.0 -
				V	±22.0 -
			+125 °C		

Selecting the Package for the Bypass Capacitor

Once the dielectric material, dielectric quality, temperature range, acceptable leakage and voltage range have been met, the final choice involves package dimensions. Typically, the package size is chosen by “what was used last time” or what is big enough to solder by hand (if a prototype).

What you need to remember is that the equivalent circuit model will change with different packages. The main issue is the equivalent series inductance (ESL). Obviously, a capacitor structure is constant as long as the capacitance value is constant. If that same capacitor is available in a variety of packages, then the connections between the plates and the outer dimensions of the package must change. This appears as additional series resistance and series inductance. The smaller the package is, the smaller the series parasitics. To demonstrate this trend, Table 4 is included. As expected, the effective series inductance decreases monotonically as package size decreases. Special attention should be paid to the 1206 and 0612 case. Although they have the same footprint, the 1206 has connections on the ends while the 0612 has connections on the longer edges. This simple change in orientation allows the inner package connections to be much smaller. Delightfully, the ESL is reduced by 95%. In wide bandwidth circuits, the amount of series inductance sets an upper bound on the ability of the bypass circuit to provide a low impedance for the power supply pin. This will be further discussed in the following sections.

Sizing Bypass Capacitors

Bypass capacitors are usually sized by convention or typical values. For example, common values are 1μF and 0.1μF. In the simplest terms, the larger value handles the lower frequencies and high current issues while the smaller value handles higher frequencies. The need for multiple capacitors comes from the parasitics associated with real capacitors.

TABLE 4. SURFACE MOUNT PACKAGES AND THEIR EQUIVALENT SERIES INDUCTANCES

PACKAGE	ESL (pH)
0201	400
0402	550
0603	700
0805	800
1206	1250
0612	63

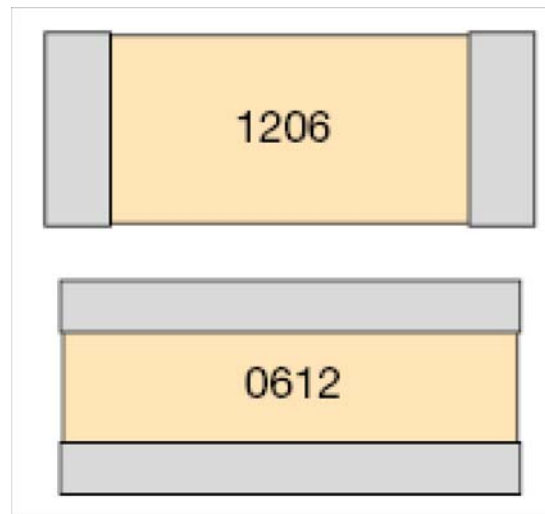

FIGURE 7. EXAMPLE SURFACE MOUNT PACKAGES IN THE 1206 ORIENTATION (TOP) AND THE 0612 ORIENTATION (BOTTOM)

Application Note 1325

Figure 8 plots the impedance of a real capacitor. The axis' are left blank so the values can be scaled to fit any capacitor. The left half of the curve represents the traditional (and ideal) capacitor response—as frequency increases, the impedance of the capacitor decreases. This is desirable, since bypass capacitors provide a low impedance (effectively a short) to AC signals on the power line. The negative slope of the line is constant, but the lateral placement of the line is dependent on the size of the capacitor. For example, a larger capacitor would shift the left half of the curve lower in frequency (farther to the left).

Any inductance in the package of the capacitor will cause a positive slope, as seen in the right half of the plot. In this region of frequencies, the inductance is canceling and then dominating the low impedance provided by the capacitor.

Since the amount of impedance is related to the size and construction of the bypass capacitor, the frequency response is likewise related.

Therefore, you want to check the data sheet to ensure that your choice of bypass capacitor is available in a package that will allow you to provide the low impedance necessary for the frequencies present in your system. Remember, the ESLs quoted in Table 4 are in the range of hundreds of picoHenries. Their rising effect on impedance only emerges when system frequencies are 100MHz.

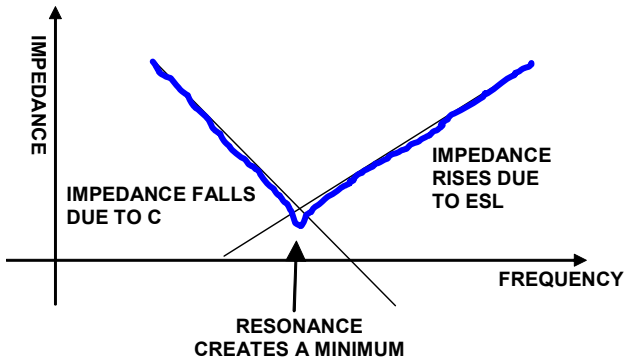

FIGURE 8. IMPEDANCE OF AN ACTUAL CAPACITOR (NON-IDEAL)

Bypassing a System with Wide Bandwidth

In some wideband systems, a single capacitor is not sufficient for bypassing. Multiple frequencies couple into the power supply lines and a bypass network must be used to provide a low impedance for a wider range of frequencies. Since the slopes, both negative and positive, of the impedance curves are physical limits, multiple capacitors are connected in parallel.

Of course, care must be taken when selecting the packages of each of the capacitors. A typical bill of materials may dictate that all passive components have the same geometry, all 0805 capacitors. The resulting impedance plot vs frequency for 3 parallel capacitors is plotted in Figure 10.

Since the same package was used for each of the capacitors, their high frequency responses are the same. Effectively, this negates the use of the smaller capacitors!

Of course, this level of detail implies that strict attention has also been paid to the layout of the bypass capacitors. Any additional trace length will also increase the impedance in the bypass path. Each trace also contributes inductance per unit length; Longer traces will lower the useful frequency of the bypass path (shifting the curves of Figures 8 through 11 to the left). Therefore, bypass capacitors should be placed as close to the power supply pins as possible. The opposite side of the capacitor needs a via to the ground plane or a wide ground trace to keep the impedance low.

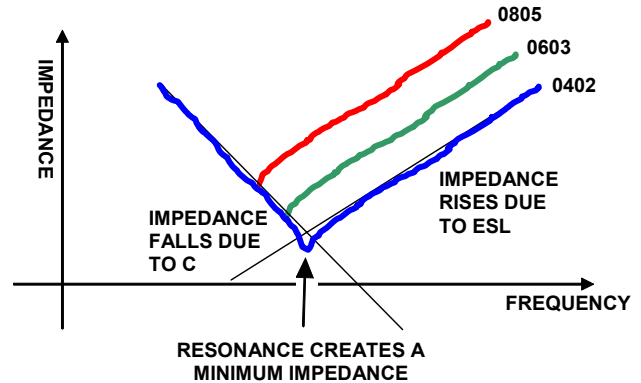

FIGURE 9. IMPEDANCE OF AN ACTUAL CAPACITOR (NON-IDEAL) IN DIFFERENT SURFACE-MOUNT PACKAGES

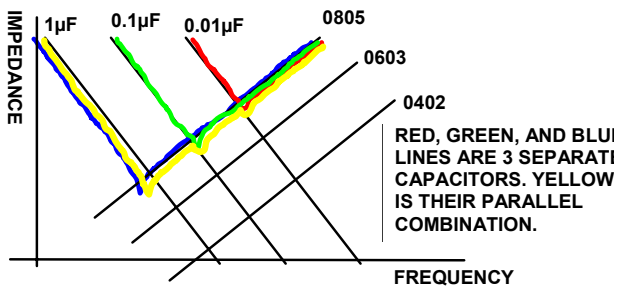

FIGURE 10. IMPEDANCE OF THREE CAPACITORS, THE SAME SURFACE-MOUNT PACKAGES

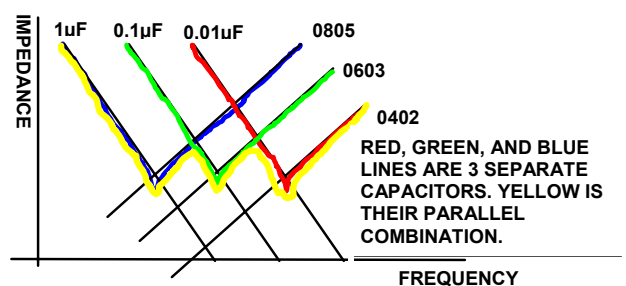

FIGURE 11. IMPEDANCE OF THREE CAPACITORS, SCALED SURFACE-MOUNT PACKAGES

Application Note 1325

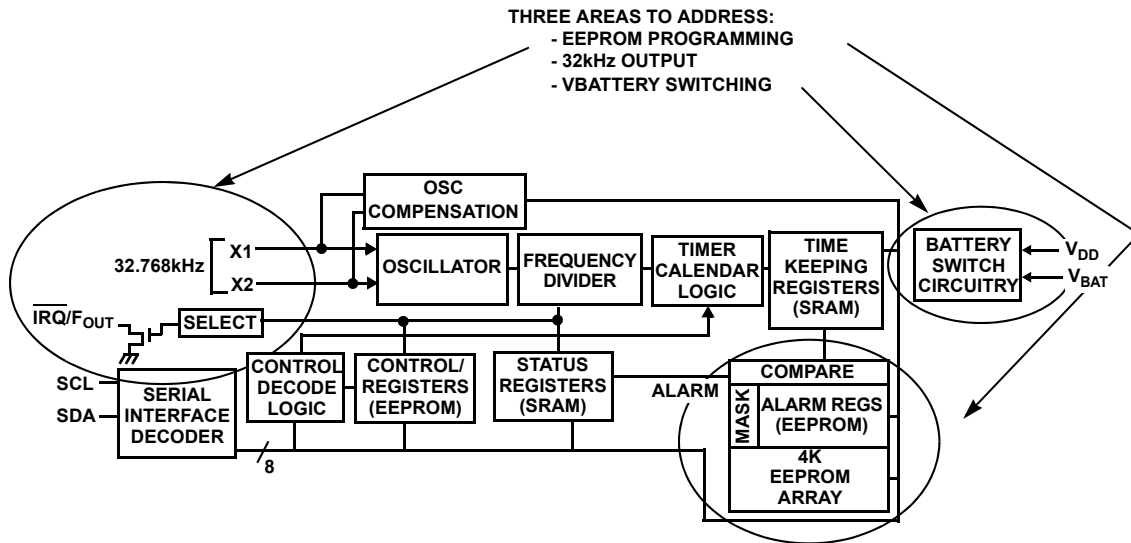

FIGURE 12. BLOCK DIAGRAM OF REAL-TIME CLOCK-CALENDAR WITH EEPROM CIRCUIT

Bypass Capacitor Application Examples

So far we have presented the main issues involved in designing optimum bypass networks. However, each circuit and each system will have specific demands that need to be addressed. The trade-offs involved in each particular instance can frustrate the best designers. Therefore, four different application examples are presented here. These examples have been chosen as representative of low current/low frequency, low current/high frequency, high current/low frequency and high current/high frequency systems. Table 5 shows the chosen circuits.

TABLE 5. APPLICATION EXAMPLES FOR BYPASS CONSIDERATION

	LOW FREQUENCY	HIGH FREQUENCY
LOW CURRENT	Real-time Clock-calendar with EEPROM	Voltage Reference
HIGH CURRENT	DC/DC Converter	DSL Amplifier

EXAMPLE 1 (LOW CURRENT/LOW FREQUENCY): REAL-TIME CLOCK-CALENDAR WITH EEPROM

The block diagram of our first example, the ISL12026 is shown in Figure 12. This system has three separate areas that require special bypass attention. Please note that this discussion assumes the use of an 8 Ld SOIC package.

The first area of concern is the EEPROM program array. To handle programming glitches, two capacitors should be placed in parallel at the supply pin, pin 8 of the SOIC. First, use a small capacitor (0.01 μ F suggested) to handle digital switching transients. Second, use a large capacitor (1 μ F suggested) to compensate for current droops on the power supply. These two capacitors should be placed in parallel between the supply node and ground.

Secondly, crystal (X1) needs to be placed as close to the device as possible to eliminate high frequency coupling. If these traces are not minimized, additional bypass capacitors will be needed on the supply to remove any coupled signals.

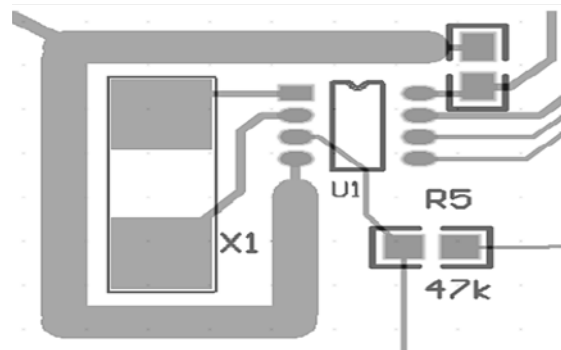

FIGURE 13. SUGGESTED LAYOUT FOR ISL12026

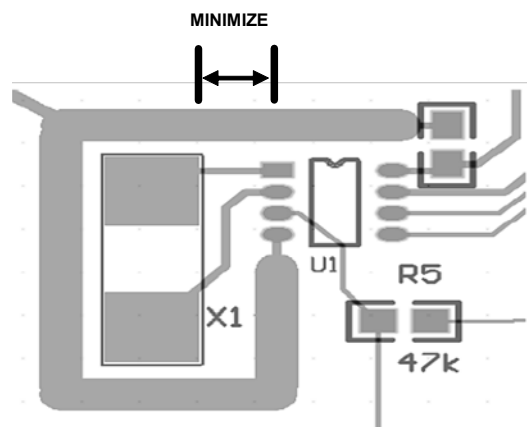

FIGURE 14. SUGGESTED LAYOUT FOR ISL12026 IN REGARDS TO CRYSTAL PLACEMENT

Application Note 1325

This device allows for battery back-up. That feature is designed with a hand-off between line and battery power. Within this hand-off region, there is an overlap where both supplies are connected to the device. This supply overlap may cause switching transients. Adding a 0.1µF capacitor in parallel with the battery will minimize these transients.

EXAMPLE 2 (LOW CURRENT/HIGH FREQUENCY): VOLTAGE REFERENCE

The block diagram of our second example uses the ISL60002 to provide a voltage reference. Although voltage references are typically considered low frequency devices, they must be bypassed over the entire bandwidth of the system they are serving. Figure 15 shows the ISL60002 voltage reference regulating the supply of a high speed ADC.

In this example (Figure 15), the input to the voltage regulator is bypassed with the standard 2-capacitor fashion previously discussed in the “sizing” section. The output of the regulator is also bypassed to provide a low-impedance supply to the ADC.

If the ADC (or any other load) has a large input capacitance, you may need to add an R-C to absorb switching transients and reduce ringing (Figure 16).

EXAMPLE 3 (HIGH CURRENT/LOW FREQUENCY): DC/DC CONVERTER

The simplified block diagram of a DC/DC converter is shown in Figure 17. A pulse-width modulator controls switches to manipulate currents through large inductors to create the desired output voltage.

The DC/DC converter circuit can be further simplified when considering only one of the switching states (Figure 18).

Typically, a lot of attention is paid to choosing the inductor. The quality of the capacitor is often taken for granted. The circuit from Figure 18 is expanded to include the parasitics of the capacitor (Figure 19).

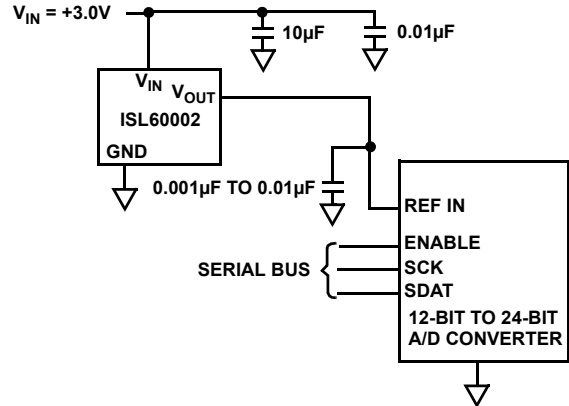

FIGURE 15. VOLTAGE REGULATOR AND ADC BLOCK DIAGRAM

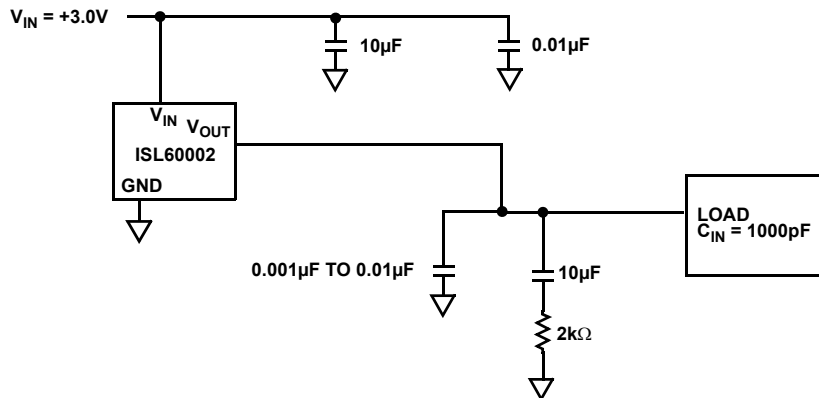

FIGURE 16. VOLTAGE REGULATOR BYPASSING WITH LARGE CAPACITIVE LOAD

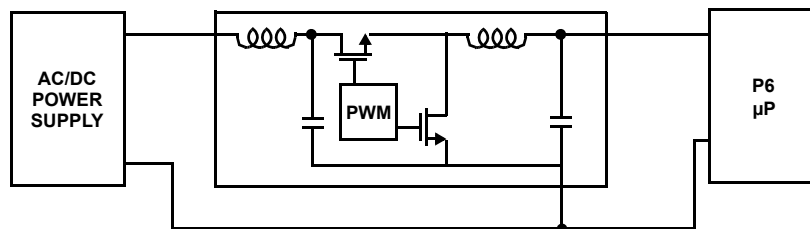

FIGURE 17. SIMPLIFIED BLOCK DIAGRAM OF A DC/DC CONVERTER

Application Note 1325

The effect of these parasitics is more apparent because of the large current through them. A summary is provided in Equation 4:

$$\Delta V_{OUT} = ESR \cdot I_{TRANSIENT} + ESL \cdot \frac{\Delta I}{\Delta T} \quad (EQ. 4)$$

The output voltage will exhibit a ripple proportional to the amount of parasitic resistance (ESR) and parasitic inductance (ESL) associated with the capacitor, C_o . The information in Table 2 allows the designer to choose the best capacitor for the performance of their DC/DC converter.

Of course, this circuit also needs bypassing at both the input and output as in the voltage regulator example. Layout is critical and multiple devices are commonly crowded around both supply terminals.

EXAMPLE 4 (HIGH CURRENT/HIGH FREQUENCY): DSL AMPLIFIER

A DSL amplifier must handle the large currents needed to drive communication lines at high speeds. Many of the same techniques reappear in this example. Again, bypass the amplifier as close to the supply pin(s) as possible. Any extra resistance (ESR) in the bypass path lowers the quality factor (Q). Likewise, any extra series inductance (ESL) lowers the self-resonant frequency of the bypass leg-possibly dipping into the bandwidth

of the system. Note that ESR and ESL are not only generated by the bypass capacitors, they also appear in traces as well as via construction.

As shown in Example 2, it is common to use at least 2 bypass capacitors in parallel. Two capacitors reside on the positive and negative supply. The smaller value capacitor appears in a smaller package and is placed closer to the device. Figure 20 presents the bypass capacitors C_1 through C_4 of the ISL1557.

When the circuit operates at especially high frequencies, a third capacitor (smaller than the other two in size and value) may also be added. The smallest capacitor should be placed closest to the supply pin to minimize parasitics. As the sizes of the capacitors increase, their respective distances from the supply pins can also increase.

Many designers like to add a series resistance to bypass capacitors to lower the quality factor (Q) of the bypass network. The effect is graphed in Figures 21 and 22 using a simple, 2-capacitor bypass network.

Adding a series resistance does indeed flatten the impedance vs frequency of the bypass network, but does not lower the overall impedance at any frequency. It is not recommended unless an especially flat frequency response is needed.

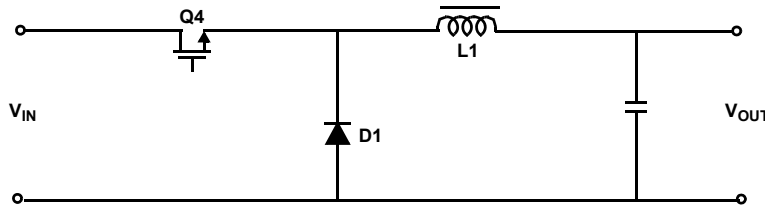

FIGURE 18. ACTIVE DC/DC CONVERTER CIRCUITRY IN ONE SWITCH CONFIGURATION

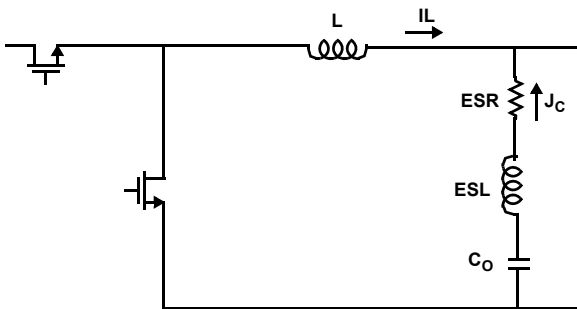

FIGURE 19. SIMPLIFIED DC/DC CONVERTER WITH CAPACITOR PARASITICS

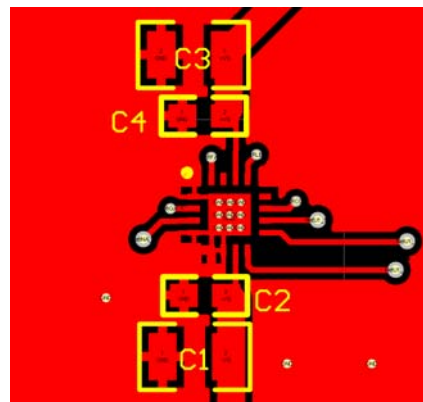

FIGURE 20. LAYOUT OF HIGH SPEED AMPLIFIER HIGHLIGHTING PLACEMENT OF BYPASS CAPACITORS

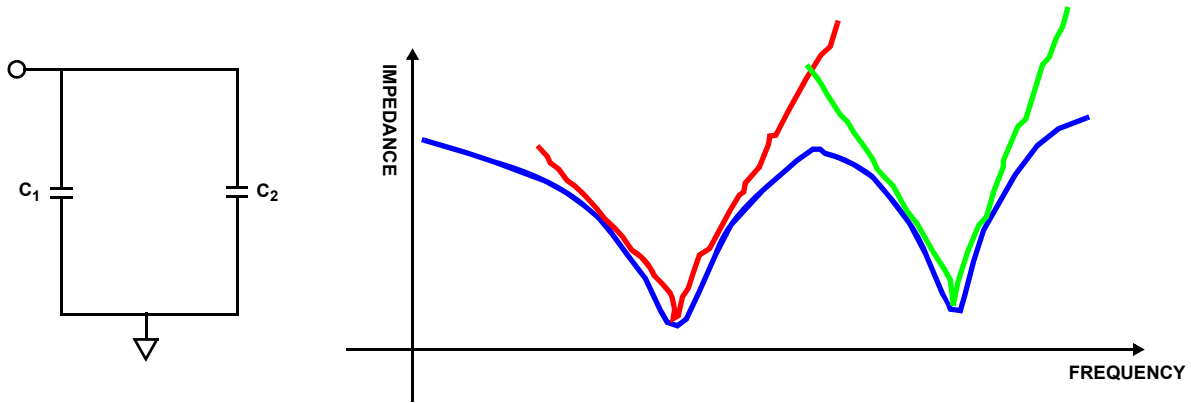

FIGURE 21. FREQUENCY RESPONSE OF TWO SCALED CAPACITORS IN PARALLEL (FOR REFERENCE)

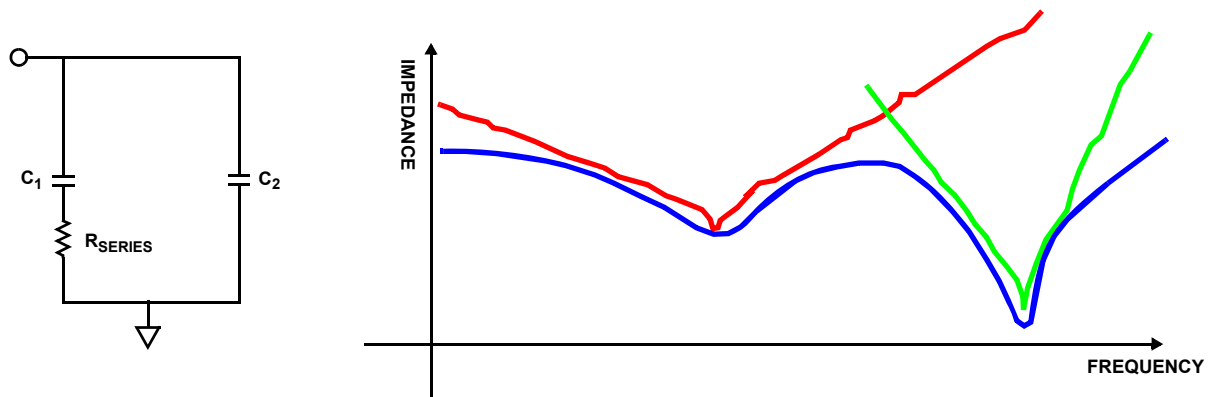

FIGURE 22. FREQUENCY RESPONSE OF TWO SCALED CAPACITORS IN PARALLEL. ONE CAPACITOR HAS BEEN DEQUED BY AN ADDITIONAL SERIES RESISTANCE

Summary

An introduction and overview of bypass capacitor and bypass techniques has been presented. Two main issues have been identified: high currents and high frequencies. Bypass capacitors must be chosen properly to handle the size and speed of transients. Parasitics need to be minimized. Many new specialized products are available for this very function (OSCON or X2Y). The most common solutions, however, use multi layer ceramic chips caps.

No matter which capacitor is chosen, layout is critical for quality bypassing. Bypass capacitors must be placed as close to the pins on the IC as possible to minimize additional ESR and ESL.

Finally, a number of applications examples are discussed. Their specifics provide insight into practical situations. One last resource is also provided (Table 6) which organizes other common circuits into our current/frequency matrix. Please use this guide to identify major issues and confidently design better bypass networks.

TABLE 6. OTHER APPLICATION CIRCUITS WITH SIMILAR CURRENT AND FREQUENCY ISSUES

	LOW FREQUENCY	HIGH FREQUENCY
LOW CURRENT	Precision Amp Light Sensors Real-time Clock/Calendar with EEPROM	High Speed Amplifier RF Amplifiers High Speed DAC/ADC
HIGH CURRENT	Sample and Hold DC Restore Amplifier DC/DC Converter	Switching Regulator RF Amplifiers Precision DAC/ADC DSL Drivers/Receivers High Speed Digital Clock

Intersil Corporation reserves the right to make changes in circuit design, software and/or specifications at any time without notice. Accordingly, the reader is cautioned to verify that the Application Note or Technical Brief is current before proceeding.

For information regarding Intersil Corporation and its products, see www.intersil.com