

LCD screens don't flicker - or do they?

LCD screens don't flicker - or do they?

When comparing CRT to LCD screens, one of the most popular differences is the issue of flicker. It is a common assumption that CRT screens flicker while LCD screens do not. In truth, both screens have some amount of flicker. The mechanisms are different and methods for correction have varying amounts of success. This appnote presents the cause of flicker in LCD screens and offers a solution for avoiding flicker by using our ISL45041/2 LCD Module Calibrator in LCD panels.

LCD screens have an array of pixels constantly lit by a backlight. The constancy of the light removes the type of flicker found in CRT screens (phosphors pulsing with each refresh cycle). Instead, an LCD pixel has upper and lower plates with grooves cut perpendicular to each other as in Figure 1. These grooves align the crystals to form channels for the backlight to pass through to the front of the panel. The amount of light emitted depends upon the orientation of the liquid crystals and is proportional to the applied voltage.

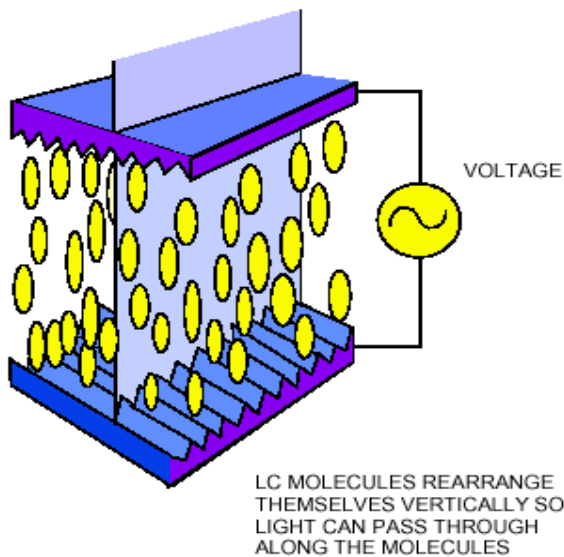

FIGURE 1. SINGLE LCD PIXEL WITH TWO GROOVED PLATES AND LIQUID CRYSTAL MOLECULES

The circuit driving a single LCD pixel is shown in Figure 2. The gate voltage acts as a switch and is commonly amplified to become -5V to 20V. The video source, typically ranging from 0V and 10V, provides the intensity information that appears across the pixel. The bottom of the pixel is commonly connected to the backplane of the panel. The voltage at this node is Vcom.

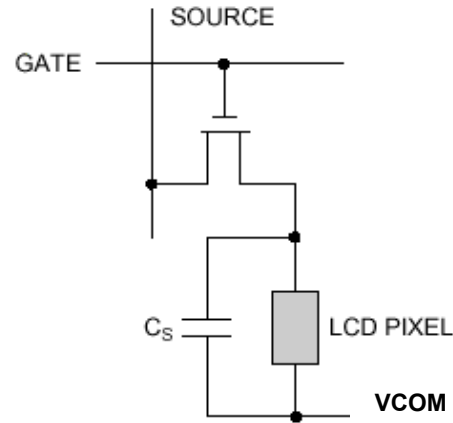

FIGURE 2. CIRCUIT DIAGRAM FOR SINGLE LCD PIXEL

While this set-up is functional, it reduces panel lifetime. Assuming the Vcom voltage is at ground, the voltage across the pixel varies from 0V to 10V. Assuming an average of 5V, there is substantial DC voltage across each pixel. This DC voltage causes charge storage, or memory. In the long term, it is a form of aging, degrading the pixels by electroplating ion impurities onto one of the electrodes of the pixel. This contributes to image retention, commonly known as a sticking image.

The construction of the LCD panel is symmetrical (Figure 1) and either a positive or a negative voltage can be used to align the crystals. One can capitalize on this aspect by moving the common voltage (Figure 2) to the midpoint of the video signal, 5V. Now the video signal swings above and below the common voltage (Vcom), creating a net zero effect on the pixel. This net zero effect on the liquid crystal eliminates the aging and image retention issues. The trade-off for this technique is resolution, since the video signal travels 5V to full brightness instead of 10V.

The Vcom voltage needs to be placed exactly at the midpoint of the video signal to avoid flicker. To illustrate why a panel will flicker, let's assume that due to manufacturing of the panel the Vcom is 5.5V. If the video signal swings between 0V and 10V, the full-scale voltage will be different on each field. On one field, the full-scale voltage will be 4.5V and on the other, the full-scale voltage will be 5.5V. This difference in full-scale voltage translates to a difference in intensity, experienced as flicker.

Due to the variations in construction of each panel, the optimal Vcom voltage can differ from panel to panel or across a single panel. Original Equipment Manufacturers must therefore adjust each of the panels coming out of the

factory to eliminate flicker. For small screens where the backplane can be considered a low-impedance ground, a single potentiometer can be added for common voltage adjustment. Traditionally, this was achieved by using mechanical potentiometers that required additional man-hours (Figure 3). This is acceptable for small panels, even though it is big in size, has low precision, and could easily break during assembly—requiring the replacement of the whole module.

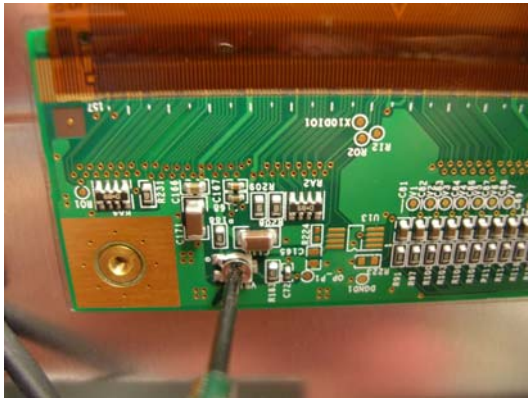

FIGURE 3. ADJUSTMENT OF POTENTIOMETER TO REDUCE FLICKER

For panels exceeding 19", the backplane cannot be considered a single low-impedance node. Multiple corrections are needed in various locations of the screen. There may be up to 5 localized compensation networks, four in the corners and one in the center. In this case, Digitally Controlled Potentiometers

(DCPs) allow the manufacturer to automate the process, a necessity for larger panels where a manual adjustment is not practical.

The system implementation and conversion from a mechanical POT to a DCP is simple. Figure 4 illustrates the system application implementation of a buffered DCP Vcom driver. The ISL45041/2 is a current output, non-volatile DCP that can operate with an AVDD of up to 20V. The ISL45041/2 uses a two-wire, up and down interface. It is an extremely accurate 7-bit device with a resolution of 128 steps. The desired Vcom value can be stored in an on-board EEPROM. The digital circuit voltage range is from 2.25V to 3.6V, this enables it to interface with many controllers used today. The analog voltage supply, running the analog resistor ladder of the device, can operate from 4.5V to 20V. This is an important characteristic for small panels that typically require less than 10V of analog supply, as well as the large panels that may require supply greater than 15V. The DCP output voltage is buffered to the Vcom bus through the EL5111 (180mA output current) amplifier.

Contrary to popular belief, LCD panels do exhibit flicker. Simple potentiometer adjustments can be made to minimize the effect since LCD flicker arises from an offset of the common voltage, not a refresh signal. As LCDs grow in popularity and in size, manual adjustment of a single point on the backplane is no longer possible. Using ISL45041/2 DCP and EL5411 Vcom buffer allow automatic correction of Vcom offsets at multiple sites on the backplane.

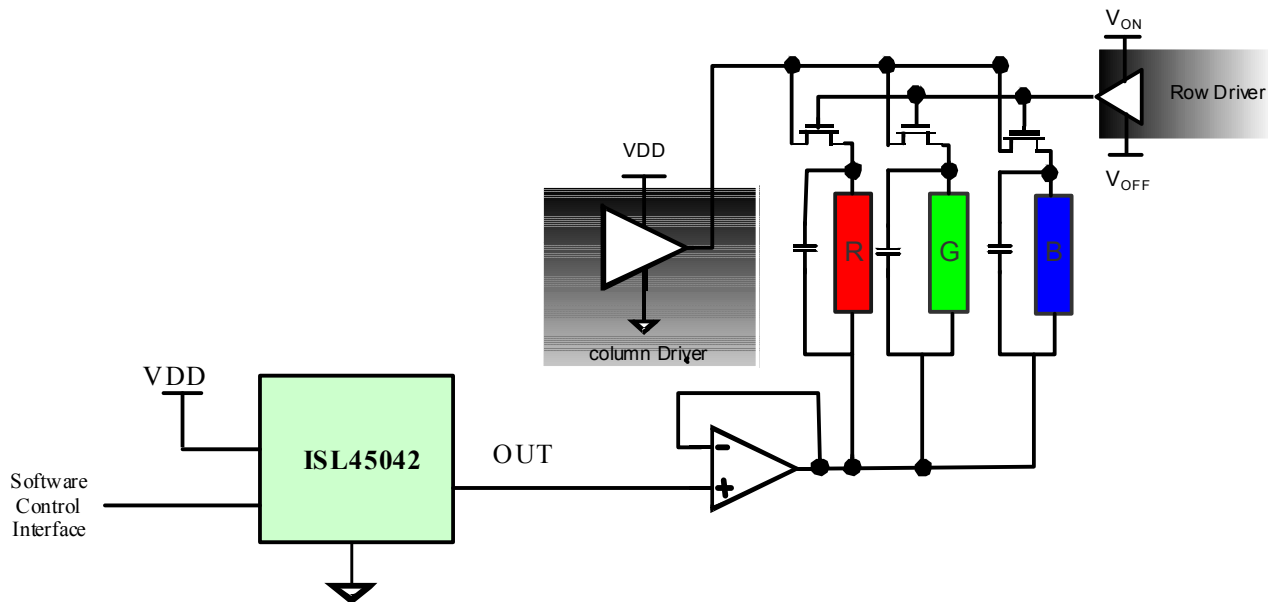

FIGURE 4. DCP SOFTWARE PROGRAMMABLE VCOM IMPLEMENTATION

Notice

1. Descriptions of circuits, software and other related information in this document are provided only to illustrate the operation of semiconductor products and application examples. You are fully responsible for the incorporation or any other use of the circuits, software, and information in the design of your product or system. Renesas Electronics disclaims any and all liability for any losses and damages incurred by you or third parties arising from the use of these circuits, software, or information.
2. Renesas Electronics hereby expressly disclaims any warranties against and liability for infringement or any other claims involving patents, copyrights, or other intellectual property rights of third parties, by or arising from the use of Renesas Electronics products or technical information described in this document, including but not limited to, the product data, drawings, charts, programs, algorithms, and application examples.
3. No license, express, implied or otherwise, is granted hereby under any patents, copyrights or other intellectual property rights of Renesas Electronics or others.
4. You shall not alter, modify, copy, or reverse engineer any Renesas Electronics product, whether in whole or in part. Renesas Electronics disclaims any and all liability for any losses or damages incurred by you or third parties arising from such alteration, modification, copying or reverse engineering.
5. Renesas Electronics products are classified according to the following two quality grades: "Standard" and "High Quality". The intended applications for each Renesas Electronics product depends on the product's quality grade, as indicated below.
"Standard": Computers; office equipment; communications equipment; test and measurement equipment; audio and visual equipment; home electronic appliances; machine tools; personal electronic equipment; industrial robots; etc.
"High Quality": Transportation equipment (automobiles, trains, ships, etc.); traffic control (traffic lights); large-scale communication equipment; key financial terminal systems; safety control equipment; etc.
Unless expressly designated as a high reliability product or a product for harsh environments in a Renesas Electronics data sheet or other Renesas Electronics document, Renesas Electronics products are not intended or authorized for use in products or systems that may pose a direct threat to human life or bodily injury (artificial life support devices or systems; surgical implantations; etc.), or may cause serious property damage (space system; undersea repeaters; nuclear power control systems; aircraft control systems; key plant systems; military equipment; etc.). Renesas Electronics disclaims any and all liability for any damages or losses incurred by you or any third parties arising from the use of any Renesas Electronics product that is inconsistent with any Renesas Electronics data sheet, user's manual or other Renesas Electronics document.
6. When using Renesas Electronics products, refer to the latest product information (data sheets, user's manuals, application notes, "General Notes for Handling and Using Semiconductor Devices" in the reliability handbook, etc.), and ensure that usage conditions are within the ranges specified by Renesas Electronics with respect to maximum ratings, operating power supply voltage range, heat dissipation characteristics, installation, etc. Renesas Electronics disclaims any and all liability for any malfunctions, failure or accident arising out of the use of Renesas Electronics products outside of such specified ranges.
7. Although Renesas Electronics endeavors to improve the quality and reliability of Renesas Electronics products, semiconductor products have specific characteristics, such as the occurrence of failure at a certain rate and malfunctions under certain use conditions. Unless designated as a high reliability product or a product for harsh environments in a Renesas Electronics data sheet or other Renesas Electronics document, Renesas Electronics products are not subject to radiation resistance design. You are responsible for implementing safety measures to guard against the possibility of bodily injury, injury or damage caused by fire, and/or danger to the public in the event of a failure or malfunction of Renesas Electronics products, such as safety design for hardware and software, including but not limited to redundancy, fire control and malfunction prevention, appropriate treatment for aging degradation or any other appropriate measures. Because the evaluation of microcomputer software alone is very difficult and impractical, you are responsible for evaluating the safety of the final products or systems manufactured by you.
8. Please contact a Renesas Electronics sales office for details as to environmental matters such as the environmental compatibility of each Renesas Electronics product. You are responsible for carefully and sufficiently investigating applicable laws and regulations that regulate the inclusion or use of controlled substances, including without limitation, the EU RoHS Directive, and using Renesas Electronics products in compliance with all these applicable laws and regulations. Renesas Electronics disclaims any and all liability for damages or losses occurring as a result of your noncompliance with applicable laws and regulations.
9. Renesas Electronics products and technologies shall not be used for or incorporated into any products or systems whose manufacture, use, or sale is prohibited under any applicable domestic or foreign laws or regulations. You shall comply with any applicable export control laws and regulations promulgated and administered by the governments of any countries asserting jurisdiction over the parties or transactions.
10. It is the responsibility of the buyer or distributor of Renesas Electronics products, or any other party who distributes, disposes of, or otherwise sells or transfers the product to a third party, to notify such third party in advance of the contents and conditions set forth in this document.
11. This document shall not be reprinted, reproduced or duplicated in any form, in whole or in part, without prior written consent of Renesas Electronics.
12. Please contact a Renesas Electronics sales office if you have any questions regarding the information contained in this document or Renesas Electronics products.
(Note 1) "Renesas Electronics" as used in this document means Renesas Electronics Corporation and also includes its directly or indirectly controlled subsidiaries.
(Note 2) "Renesas Electronics product(s)" means any product developed or manufactured by or for Renesas Electronics.

(Rev.4.0-1 November 2017)



SALES OFFICES

Renesas Electronics Corporation

<http://www.renesas.com>

Refer to "<http://www.renesas.com/>" for the latest and detailed information.

Renesas Electronics America Inc.
1001 Murphy Ranch Road, Milpitas, CA 95035, U.S.A.
Tel: +1-408-432-8888, Fax: +1-408-434-5351

Renesas Electronics Canada Limited
9251 Yonge Street, Suite 8309 Richmond Hill, Ontario Canada L4C 9T3
Tel: +1-905-237-2004

Renesas Electronics Europe Limited
Dukes Meadow, Millboard Road, Bourne End, Buckinghamshire, SL8 5FH, U.K
Tel: +44-1628-651-700, Fax: +44-1628-651-804

Renesas Electronics Europe GmbH
Arcadiastrasse 10, 40472 Düsseldorf, Germany
Tel: +49-211-6503-0, Fax: +49-211-6503-1327

Renesas Electronics (China) Co., Ltd.
Room 1709 Quantum Plaza, No.27 ZhichunLu, Haidian District, Beijing, 100191 P. R. China
Tel: +86-10-8235-1155, Fax: +86-10-8235-7679

Renesas Electronics (Shanghai) Co., Ltd.
Unit 301, Tower A, Central Towers, 555 Langao Road, Putuo District, Shanghai, 200333 P. R. China
Tel: +86-21-2226-0888, Fax: +86-21-2226-0999

Renesas Electronics Hong Kong Limited
Unit 1601-1611, 16/F., Tower 2, Grand Century Place, 193 Prince Edward Road West, Mongkok, Kowloon, Hong Kong
Tel: +852-2265-6688, Fax: +852-2886-9022

Renesas Electronics Taiwan Co., Ltd.
13F, No. 363, Fu Shing North Road, Taipei 10543, Taiwan
Tel: +886-2-8175-9600, Fax: +886-2-8175-9670

Renesas Electronics Singapore Pte. Ltd.
80 Bendemeer Road, Unit #06-02 Hyflux Innovation Centre, Singapore 339949
Tel: +65-6213-0200, Fax: +65-6213-0300

Renesas Electronics Malaysia Sdn.Bhd.
Unit 1207, Block B, Menara Amcorp, Amcorp Trade Centre, No. 18, Jln Persiaran Barat, 46050 Petaling Jaya, Selangor Darul Ehsan, Malaysia
Tel: +60-3-7955-9390, Fax: +60-3-7955-9510

Renesas Electronics India Pvt. Ltd.
No.777C, 100 Feet Road, HAL 2nd Stage, Indiranagar, Bangalore 560 038, India
Tel: +91-80-67208700, Fax: +91-80-67208777

Renesas Electronics Korea Co., Ltd.
17F, KAMCO Yangjae Tower, 262, Gangnam-daero, Gangnam-gu, Seoul, 06265 Korea
Tel: +82-2-558-3737, Fax: +82-2-558-5338