

X4C105 NOVRAM Features and Applications

AN1146
Rev 0.00
April 21, 2005

Introduction

Have you ever experienced a power failure during a “save to disk” operation, then wondered, “Is my file saved correctly?” Have you had the need to track a critical process where a power glitch can cause the loss of status and result in production loss? Are you using a microprocessor or microcontroller and need some outputs for controlling external circuitry? If these outputs can remember their last state and configure the circuitry very fast, even before the processor initializes, would that be useful? For these, and many other applications, the X4C105 is the device to choose.

Features

The low voltage X4C105 combines several functions into one device. The first is a 2-wire, 4Kbit serial EEPROM memory with write protection. A Write Protect (WP) pin provides hardware protection for the upper half of the EEPROM against inadvertent writes.

The X4C105 contains a 4bit wide NOVRAM. A NOVRAM is a static RAM with a shadow EEPROM. The static RAM part accesses very quickly, with reads and writes taking 150nS maximum. During a power fail condition, the contents of the static RAM are saved to the shadow EEPROM. When power is restored, the EEPROM is recalled to the static RAM. The static RAM provides a convenient way to save fast changing status bits that must remain true in the event of a power failure.

During a power fail or brown out condition, a low voltage detect circuit activates a /RESET pin when Vcc drops below 3V. This signal also blocks new read or write operations to minimize EEPROM corruption and initiates a NOVRAM AUTOSTORE.

The value contained in the four NOVRAM bits also appear on four separate output pins to allow continuous control of external circuitry, such as ASICs. These outputs can serve as DIP switch replacements or can “pre-configure” the hardware, prior to microprocessor initialization.

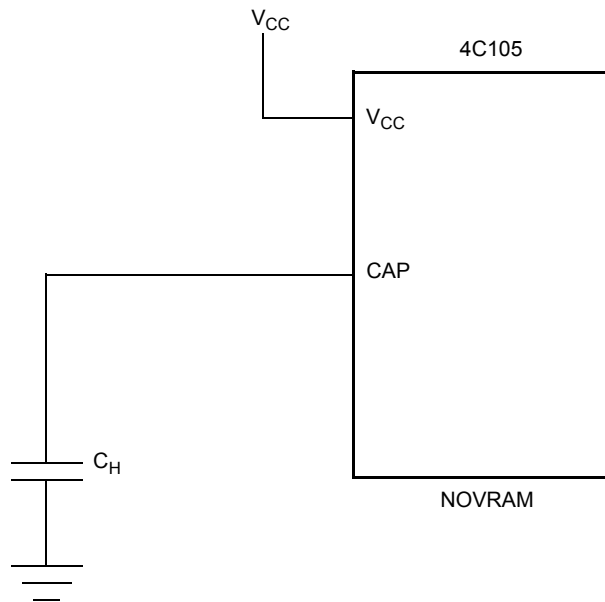

FIGURE 1. CAPACITOR SWITCH CIRCUIT

How Autostore Works

The X4C105 includes an Autostore feature that utilizes an external capacitor to supply enough power to perform the store operation when system V_{CC} drops below approximately 2.95 volts. Data is automatically stored and is guaranteed nonvolatile for a maximum of 10 years at operating temperature.

The X4C105 was designed to use only a single capacitor to provide the voltage for the NOVRAM backup operation, as shown in Figure 1. This "hold-up" capacitor must be capable of supplying the maximum Autostore current (I_{CC} max.) for the maximum Autostore period (T_{ASTO} max.) as V_{CC} falls to a level between the Autostore threshold voltage (V_{ASTH} min.) and the Autostore end voltage (V_{ASEND} min.).

The "hold-up" capacitor value (C_H) is calculated using the equation:

$$C_H = \frac{(I_{CC3} \text{ max}) (T_{ASTO} \text{ max})}{V_{ASTH} \text{ min} - V_{ASEND} \text{ min}}$$

$$C_H = \frac{(3\text{mA}) (5\text{mS for NOVRAM}^*)}{2.8\text{V} - 2.0\text{V}} \approx 43\mu\text{F}$$

* add 5mS more if doing a serial store when power fails

and is derived by taking the integral of:

$$i = C \frac{dV}{dt}$$

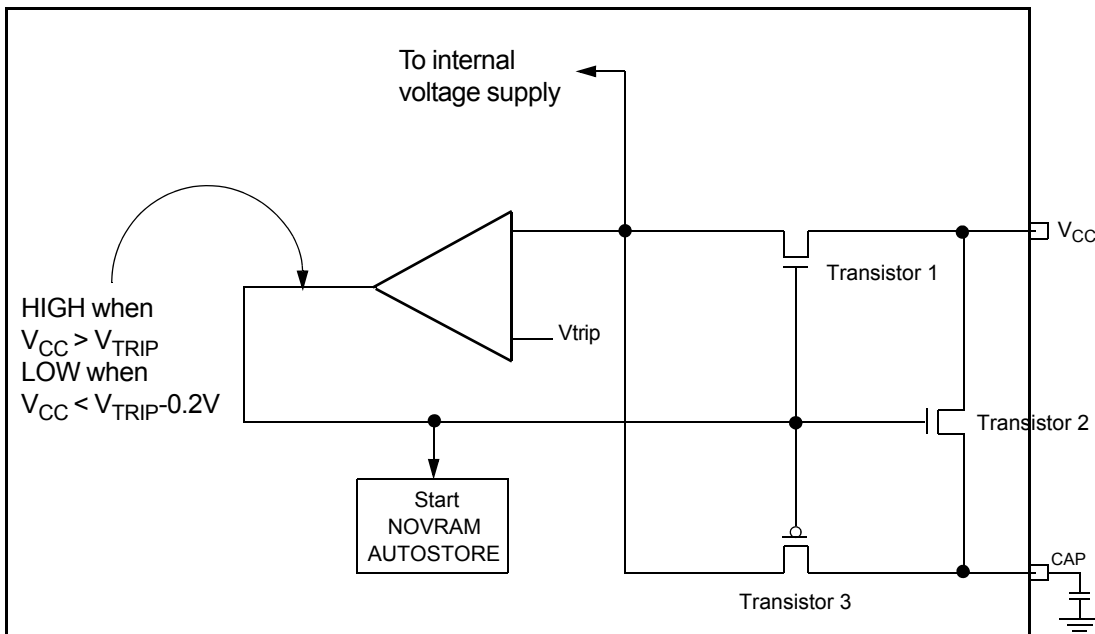

FIGURE 2. LOW POWER SENSE CIRCUIT

How the Low Power Sense Circuit Works

At system power-up, V_{cc} ramps up and exceeds V_{trip} that is set at between 2.8 to 2.95 volts. The low power sense circuitry creates a high level output signal which turns on transistors 1 and 2, and turns off transistor 3 as shown in Figure 2. While transistor 1 and 2 are ON, power goes to all internal circuits and also charges the external capacitor. When power fails, transistors 1 and 2 are off to prevent the capacitor from discharging into the system circuitry. Transistor 3 is on to supply power from the cap to the device internal circuits.

RAID Server Application

The term RAID (Redundant Array of Independent Disks) first appeared 5 years ago in papers written by Garth Gibson, Randy Katz, and Dave Patterson of the University of California at Berkeley.

The major task for the designer of RAID systems is to assure that data stored in the array can never be lost due to hardware failure. Major users of disk array systems such as banks, airlines, and credit agencies must be certain that they can never lose a disk in such a manner that the data stored on that disk is not recoverable. Even frequent and conscientious backing up of all disk storage does not recover new data that has been written since the last backup cycle was performed. The primary problem with the RAID systems is that if a power failure occurs, and the system's microcontroller volatile system memory is lost, the entire disk array must be scanned upon power-up to reestablish configuration and to redefine data locations. A solution to this data reliability problem is the use of the X4C105, CPU Supervisor with EEPROM, NOVRAM and Ports.

First, the X4C105 offers a separate serial 4Kbit nonvolatile EEPROM with write protection capability that can be used to store the system configuration data. When the low power sense circuitry detects the system power fails, no writes are allowed to the serial memory to prevent any data corruption. This will ensure that the system configuration data can be easily recovered after the system power was interrupted to avoid any system's down time.

Second, the X4C105 also has a 4bits NOVRAM utilized parallel interface for fast access. The four NOVRAM bits also appear on four separate output pins to allow continuous control of external circuitry such as monitoring the cache memory within the RAID. In the RAID server application, a 64Mb cache is used to temporarily store the data before it transfers to the hard disk. Just prior to the backup of the cache to the hard disk, the microcontroller sets one of the SRAM bits to "1". When the write operation is completed, microcontroller sets SRAM bit back to "0". If there is a power interruption during the write operation, the SRAM bit indicating a backup was in progress will be automatically saved into EEPROM memory. So

when the system recovers from power loss, the X4C105 auto-recall of the backup in progress flag indicates that there was an incomplete write operation and the data written into the hard disk has been corrupted. This will prevent the ambiguous "Your data may have been lost" message and prevent unnecessary disk restoration operations.

Dip Switch Control Application

In many systems, printed circuit boards use dip switches or jumpers to allow users to alter settings for different configurations. The X4C105 offers four NOVRAM bits that appear on four separate output pins to allow continuous control external circuitry. For example, the user can preprogram the dip switch control setting using the four NOVRAM bits. Then, every time at power-up the preset values are automatically recalled and the outputs set to the preassigned desired settings. This eliminates the use of the dip switches and allows the user to change the setting from a remote area using a modem.

Re-Write Application

The X4C105 can improve process control systems. For example, a blood analyzer that needs to run through several preprogrammed tests could use the X4C105 NOVRAM to track the progress of the analysis. At each step a reagent is added for a particular test. If power fails the system and can't tell where it was, so must run the test again. By using the 16 NOVRAM states, the equipment knows where it was when power fails and can continue as if there was no interruption. The same could apply to chemical or manufacturing processes. It could even apply to software operations.

Conclusion

The X4C105 is a highly integrated device that combines CPU Supervisor with EEPROM, NOVRAM and output buffers and latches. The 4Kbit serial EEPROM stores configuration data for calibration. Low power sense circuitry monitors the level of the supply voltage. In the event of power failure, the device signals the microcontroller to shut down before the system locks up. In addition, the NOVRAM performs an autostore to save data into the EEPROM to preserve the condition just prior to power failure.

Notice

1. Descriptions of circuits, software and other related information in this document are provided only to illustrate the operation of semiconductor products and application examples. You are fully responsible for the incorporation or any other use of the circuits, software, and information in the design of your product or system. Renesas Electronics disclaims any and all liability for any losses and damages incurred by you or third parties arising from the use of these circuits, software, or information.
 2. Renesas Electronics hereby expressly disclaims any warranties against and liability for infringement or any other claims involving patents, copyrights, or other intellectual property rights of third parties, by or arising from the use of Renesas Electronics products or technical information described in this document, including but not limited to, the product data, drawings, charts, programs, algorithms, and application examples.
 3. No license, express, implied or otherwise, is granted hereby under any patents, copyrights or other intellectual property rights of Renesas Electronics or others.
 4. You shall not alter, modify, copy, or reverse engineer any Renesas Electronics product, whether in whole or in part. Renesas Electronics disclaims any and all liability for any losses or damages incurred by you or third parties arising from such alteration, modification, copying or reverse engineering.
 5. Renesas Electronics products are classified according to the following two quality grades: "Standard" and "High Quality". The intended applications for each Renesas Electronics product depends on the product's quality grade, as indicated below.
"Standard": Computers; office equipment; communications equipment; test and measurement equipment; audio and visual equipment; home electronic appliances; machine tools; personal electronic equipment; industrial robots; etc.
"High Quality": Transportation equipment (automobiles, trains, ships, etc.); traffic control (traffic lights); large-scale communication equipment; key financial terminal systems; safety control equipment; etc.
Unless expressly designated as a high reliability product or a product for harsh environments in a Renesas Electronics data sheet or other Renesas Electronics document, Renesas Electronics products are not intended or authorized for use in products or systems that may pose a direct threat to human life or bodily injury (artificial life support devices or systems; surgical implantations; etc.), or may cause serious property damage (space system; undersea repeaters; nuclear power control systems; aircraft control systems; key plant systems; military equipment; etc.). Renesas Electronics disclaims any and all liability for any damages or losses incurred by you or any third parties arising from the use of any Renesas Electronics product that is inconsistent with any Renesas Electronics data sheet, user's manual or other Renesas Electronics document.
 6. When using Renesas Electronics products, refer to the latest product information (data sheets, user's manuals, application notes, "General Notes for Handling and Using Semiconductor Devices" in the reliability handbook, etc.), and ensure that usage conditions are within the ranges specified by Renesas Electronics with respect to maximum ratings, operating power supply voltage range, heat dissipation characteristics, installation, etc. Renesas Electronics disclaims any and all liability for any malfunctions, failure or accident arising out of the use of Renesas Electronics products outside of such specified ranges.
 7. Although Renesas Electronics endeavors to improve the quality and reliability of Renesas Electronics products, semiconductor products have specific characteristics, such as the occurrence of failure at a certain rate and malfunctions under certain use conditions. Unless designated as a high reliability product or a product for harsh environments in a Renesas Electronics data sheet or other Renesas Electronics document, Renesas Electronics products are not subject to radiation resistance design. You are responsible for implementing safety measures to guard against the possibility of bodily injury, injury or damage caused by fire, and/or danger to the public in the event of a failure or malfunction of Renesas Electronics products, such as safety design for hardware and software, including but not limited to redundancy, fire control and malfunction prevention, appropriate treatment for aging degradation or any other appropriate measures. Because the evaluation of microcomputer software alone is very difficult and impractical, you are responsible for evaluating the safety of the final products or systems manufactured by you.
 8. Please contact a Renesas Electronics sales office for details as to environmental matters such as the environmental compatibility of each Renesas Electronics product. You are responsible for carefully and sufficiently investigating applicable laws and regulations that regulate the inclusion or use of controlled substances, including without limitation, the EU RoHS Directive, and using Renesas Electronics products in compliance with all these applicable laws and regulations. Renesas Electronics disclaims any and all liability for damages or losses occurring as a result of your noncompliance with applicable laws and regulations.
 9. Renesas Electronics products and technologies shall not be used for or incorporated into any products or systems whose manufacture, use, or sale is prohibited under any applicable domestic or foreign laws or regulations. You shall comply with any applicable export control laws and regulations promulgated and administered by the governments of any countries asserting jurisdiction over the parties or transactions.
 10. It is the responsibility of the buyer or distributor of Renesas Electronics products, or any other party who distributes, disposes of, or otherwise sells or transfers the product to a third party, to notify such third party in advance of the contents and conditions set forth in this document.
 11. This document shall not be reprinted, reproduced or duplicated in any form, in whole or in part, without prior written consent of Renesas Electronics.
 12. Please contact a Renesas Electronics sales office if you have any questions regarding the information contained in this document or Renesas Electronics products.
- (Note 1) "Renesas Electronics" as used in this document means Renesas Electronics Corporation and also includes its directly or indirectly controlled subsidiaries.
(Note 2) "Renesas Electronics product(s)" means any product developed or manufactured by or for Renesas Electronics.

(Rev.4.0-1 November 2017)



SALES OFFICES

Renesas Electronics Corporation

<http://www.renesas.com>

Refer to "<http://www.renesas.com/>" for the latest and detailed information.

Renesas Electronics America Inc.
1001 Murphy Ranch Road, Milpitas, CA 95035, U.S.A.
Tel: +1-408-432-8888, Fax: +1-408-434-5351

Renesas Electronics Canada Limited
9251 Yonge Street, Suite 8309 Richmond Hill, Ontario Canada L4C 9T3
Tel: +1-905-237-2004

Renesas Electronics Europe Limited
Dukes Meadow, Millboard Road, Bourne End, Buckinghamshire, SL8 5FH, U.K.
Tel: +44-1628-651-700, Fax: +44-1628-651-804

Renesas Electronics Europe GmbH
Arcadiastrasse 10, 40472 Düsseldorf, Germany
Tel: +49-211-6503-0, Fax: +49-211-6503-1327

Renesas Electronics (China) Co., Ltd.
Room 1709 Quantum Plaza, No.27 ZhichunLu, Haidian District, Beijing, 100191 P. R. China
Tel: +86-10-8235-1155, Fax: +86-10-8235-7679

Renesas Electronics (Shanghai) Co., Ltd.
Unit 301, Tower A, Central Towers, 555 Langao Road, Putuo District, Shanghai, 200333 P. R. China
Tel: +86-21-2226-0888, Fax: +86-21-2226-0999

Renesas Electronics Hong Kong Limited
Unit 1601-1611, 16/F., Tower 2, Grand Century Place, 193 Prince Edward Road West, Mongkok, Kowloon, Hong Kong
Tel: +852-2265-6688, Fax: +852-2886-9022

Renesas Electronics Taiwan Co., Ltd.
13F, No. 363, Fu Shing North Road, Taipei 10543, Taiwan
Tel: +886-2-8175-9600, Fax: +886-2-8175-9670

Renesas Electronics Singapore Pte. Ltd.
80 Bendemeer Road, Unit #06-02 Hyflux Innovation Centre, Singapore 339949
Tel: +65-6213-0200, Fax: +65-6213-0300

Renesas Electronics Malaysia Sdn.Bhd.
Unit 1207, Block B, Menara Amcorp, Amcorp Trade Centre, No. 18, Jln Persiaran Barat, 46050 Petaling Jaya, Selangor Darul Ehsan, Malaysia
Tel: +60-3-7955-9390, Fax: +60-3-7955-9510

Renesas Electronics India Pvt. Ltd.
No.777C, 100 Feet Road, HAL 2nd Stage, Indiranagar, Bangalore 560 038, India
Tel: +91-80-67208700, Fax: +91-80-67208777

Renesas Electronics Korea Co., Ltd.
17F, KAMCO Yangjae Tower, 262, Gangnam-daero, Gangnam-gu, Seoul, 06265 Korea
Tel: +82-2-558-3737, Fax: +82-2-558-5338