

## **Introduction**

The intense, heavy ion environment encountered in space applications can cause a variety of effects in electronic circuitry, including Single Event Transient (SET), Single Event Latchup (SEL) and Single Event Burnout (SEB). These Single Event Effects (SEE) can lead to system-level performance issues including disruption, degradation and destruction. For predictable and reliable space system operation, individual electronic components should be characterized to determine their SEE response. This report discusses the results of SEE testing performed on the ISL7457SRH non-inverting, quad CMOS driver.

## **Product Description**

The ISL7457SRH is a monolithic, non-inverting, quad CMOS driver fabricated on a Bi-CMOS junction isolated process. The ISL7457SRH has a Total Ionizing Dose (TID) capability of 10 krads(Si) at both high and low dose rates.

Functionally, the ISL7457SRH is a high speed, non-inverting, quad CMOS driver featuring 2 A peak drive currents and tri-stable outputs. Typical applications include clock/line driver, CCD driver and level-shifter.

## **SEE Test Objectives**

The ISL7457SRH was tested for SEE to determine its susceptibility to SEL/SEB and to characterize its SET behavior.

## **SEE Test Facility**

Testing was performed at the Texas A&M University Cyclotron Institute heavy ion facility. This facility is coupled to a K500 super-conducting cyclotron, which is capable of generating a wide range of test particles with the various energy, flux and fluence levels needed for advanced radiation testing.

## **SEE Test Plan**

A schematic of the ISL7457SRH SEE test circuit is shown in Figure 1. The inputs to the A and B drivers were tied to VS through a 10 k $\Omega$  resistor, so the A and B driver outputs were normally high. The inputs to the C and D drivers were tied to ground, so the C and D driver outputs were normally low. Also, the outputs of the A and B drivers were tied to VS through 1 k $\Omega$  resistors, while the outputs of the C and D drivers were tied to ground through 1 k $\Omega$  resistors. In this circuit configuration, a transient on any of the driver outputs caused the VS supply current to increase, which was detected by measuring an increase in voltage drop

across diode, D1. Average supply voltage and average supply current were monitored using digital multimeters. The voltage across D1 and all four driver outputs were monitored using digitizing oscilloscopes. The voltage across D1 provided the trigger source for all testing. All connections from the test circuit to the test equipment were made through approximately 20 feet of coaxial cable.

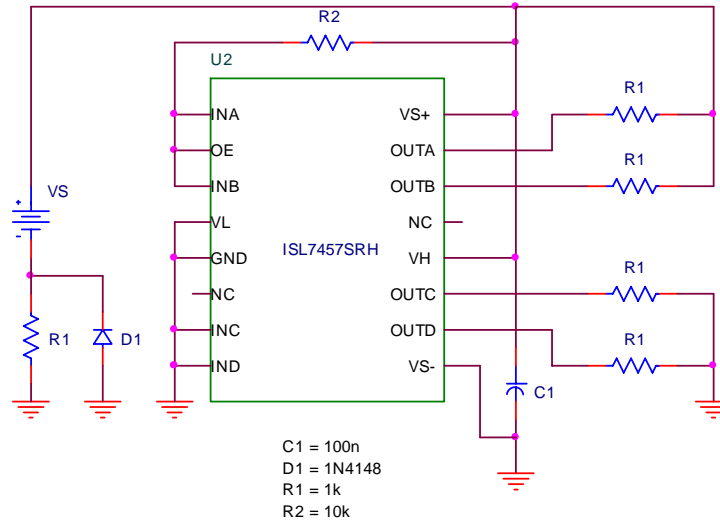

**Figure 1: ISL7457SRH SEE Test Circuit Schematic**

Table 1 shows the beam characteristics used during SEE testing.

Ion Species	Incident Angle (°)	LET (MeV/mg/cm <sup>2</sup> )	LET <sub>eff</sub> (MeV/mg/cm <sup>2</sup> )	Flux (ions/cm <sup>2</sup> /s)	Fluence (ions/cm <sup>2</sup> )	Effective Fluence (ions/cm <sup>2</sup> )
Au	0	85.4	85.4	1 x 10 <sup>4</sup>	1.95 x 10 <sup>6</sup>	1.95 x 10 <sup>6</sup>
Ag	0	42.2	42.2	1 x 10 <sup>4</sup>	3.9 x 10 <sup>6</sup>	3.9 x 10 <sup>6</sup>
Ag	48.2	43.2	64.8	1 x 10 <sup>4</sup>	2 x 10 <sup>6</sup>	1.33 x 10 <sup>6</sup>
Ag	60	43.2	86.4	1 x 10 <sup>4</sup>	2 x 10 <sup>6</sup>	1 x 10 <sup>6</sup>

**Table 1: Beam Characteristics**

Neutron irradiated devices were used for some of the SEE tests in hopes of improving SEL performance. Neutron irradiation reduces the gain of parasitic bipolar transistors that are implicated in latchup. Characteristics of the neutron irradiation are shown in Table 2.

Energy (MeV)	Fluence (neutrons/cm <sup>2</sup> )	Effective Fluence* (neutrons/cm <sup>2</sup> )
1.0 (silicon equivalent)	$3 \times 10^{13}$	$1 \times 10^{13}$

\* Package anneal removes ~2/3 of the neutron damage

**Table 2: Neutron Irradiation Characteristics**

Table 3 shows the SEE tests that were performed. A transient was defined to be a movement of > 50% of the supply voltage on a driver output that was detected as a ~100 mV change in voltage drop across D1.

Test ID	Ion Species	LET <sub>eff</sub> (MeV/mg/cm <sup>2</sup> )	Test Conditions	Transient Count
120	Au	85.4	Per Figure 1 schematic, V <sub>S</sub> = 15 V, T <sub>C</sub> = 25°C	NA*
122	Au	85.4	Per Figure 1 schematic, V <sub>S</sub> = 15 V, T <sub>C</sub> = 25°C	NA*
123	Au	85.4	Per Figure 1 schematic, V <sub>S</sub> = 15 V, T <sub>C</sub> = 25°C	NA*
231	Ag	42.2	Per Figure 1 schematic, V <sub>S</sub> = 15 V, T <sub>C</sub> = 25°C	12
232	Ag	42.2	Per Figure 1 schematic, V <sub>S</sub> = 15 V, T <sub>C</sub> = 25°C	11
233	Ag	42.2	Per Figure 1 schematic, V <sub>S</sub> = 15 V, T <sub>C</sub> = 25°C	12
234	Ag	42.2	Per Figure 1 schematic, V <sub>S</sub> = 15 V, T <sub>C</sub> = 25°C	12
105	Ag	64.8	Per Figure 1 schematic, V <sub>S</sub> = 14.7 V, T <sub>C</sub> = 85°C, neutron irradiated device	NA*
107	Ag	64.8	Per Figure 1 schematic, V <sub>S</sub> = 14 V, T <sub>C</sub> = 85°C, neutron irradiated device	NA*
104	Ag	86.4	Per Figure 1 schematic, V <sub>S</sub> = 6.1 V, T <sub>C</sub> = 125°C, neutron irradiated device	78
108	Ag	86.4	Per Figure 1 schematic, V <sub>S</sub> = 6.1 V, T <sub>C</sub> = 125°C, neutron irradiated device	96
106	Ag	86.4	Per Figure 1 schematic, V <sub>S</sub> = 6.1 V, T <sub>C</sub> = 125°C, neutron irradiated device	97
109	Ag	86.4	Per Figure 1 schematic, V <sub>S</sub> = 6.1 V, T <sub>C</sub> = 125°C, neutron irradiated device	89
111	Ag	86.4	Per Figure 1 schematic, V <sub>S</sub> = 6.1 V, T <sub>C</sub> = 125°C, neutron irradiated device	84

\* Not Applicable due to device failure.

**Table 3: SEE Tests**

### **Au Ion Testing ( $LET_{\text{eff}} = 85.4 \text{ MeV/mg/cm}^2$ )**

Three devices were irradiated with Au ions at an  $LET_{\text{eff}} = 85.4 \text{ MeV/mg/cm}^2$ , a flux of  $1 \times 10^4 \text{ ions/cm}^2/\text{s}$ ,  $V_S = 15 \text{ V}$  and  $T_C = 25^\circ\text{C}$ . The target effective fluence for each test was  $1.95 \times 10^6 \text{ ions/cm}^2$ . All three devices failed after less than one minute of irradiation, so actual effective fluence was  $< 6 \times 10^5 \text{ ions/cm}^2$ . After failure, average supply current on all three devices increased from  $\sim 1 \text{ mA}$  to  $> 800 \text{ mA}$ . Prior to failure, some spiking of the supply current was observed, but this did not appreciably affect the level of the driver outputs. Numerous short ( $< 500 \text{ ns}$ ) low-high-low transients were observed on the C and D driver outputs. Also, a few longer duration ( $> 18 \text{ us}$ ) high-low transients were observed on the A and B driver outputs.

### **Ag Ion Testing ( $LET_{\text{eff}} = 42.2 \text{ MeV/mg/cm}^2$ )**

Four devices were irradiated with Ag ions at an  $LET_{\text{eff}} = 42.2 \text{ MeV/mg/cm}^2$ , a flux of  $1 \times 10^4 \text{ ions/cm}^2/\text{s}$ ,  $V_S = 15 \text{ V}$  and  $T_C = 25^\circ\text{C}$ . The effective fluence during irradiation was  $3.9 \times 10^6 \text{ ions/cm}^2$ . There was negligible change in average supply current after testing, indicating no permanent damage was incurred. Some spiking of the supply current was observed, but this did not appreciably affect the level of the driver outputs. Numerous short ( $< 500 \text{ ns}$ ) low-high-low transients were observed on the outputs of the C and D drivers. The cross section of the device was computed by dividing the total number of transients observed for all four devices by the total effective fluence seen by all four devices. Therefore, cross section = total number of transients / total effective fluence =  $47 / 15.6 \times 10^6 \text{ ions/cm}^2 = 3.01 \times 10^{-6} \text{ cm}^2$ .

### **Ag Ion Testing ( $LET_{\text{eff}} = 64.8 \text{ MeV/mg/cm}^2$ )**

One neutron irradiated device was irradiated with Ag ions at an  $LET_{\text{eff}} = 64.8 \text{ MeV/mg/cm}^2$ , a flux of  $1 \times 10^4 \text{ ions/cm}^2/\text{s}$ ,  $V_S = 14.7 \text{ V}$  and  $T_C = 85^\circ\text{C}$ . The target effective fluence for the test was  $1.33 \times 10^6 \text{ ions/cm}^2$ . The device failed after 67 s, so actual effective fluence was  $4.04 \times 10^5 \text{ ions/cm}^2$ . After failure, average supply current increased from  $< 1 \text{ mA}$  to  $\sim 6 \text{ mA}$ .

One neutron irradiated device was irradiated with Ag ions at an  $LET_{\text{eff}} = 64.8 \text{ MeV/mg/cm}^2$ , a flux of  $1 \times 10^4 \text{ ions/cm}^2/\text{s}$ ,  $V_S = 14 \text{ V}$  and  $T_C = 85^\circ\text{C}$ . The target effective fluence for the test was  $1.33 \times 10^6 \text{ ions/cm}^2$ . The device failed after 132 s, so actual effective fluence was  $8.58 \times 10^5 \text{ ions/cm}^2$ . After failure, average supply current increased from  $< 1 \text{ mA}$  to  $\sim 600 \text{ mA}$ .

### **Ag ion Testing ( $LET_{\text{eff}} = 86.4 \text{ MeV/mg/cm}^2$ )**

Five neutron irradiated devices were irradiated with Ag ions at an  $LET_{\text{eff}} = 86.4 \text{ MeV/mg/cm}^2$ , a flux of  $1 \times 10^4 \text{ ions/cm}^2/\text{s}$ ,  $V_S = 6.1 \text{ V}$  and  $T_C = 125^\circ\text{C}$ . The effective fluence during irradiation was  $1 \times 10^6 \text{ ions/cm}^2$ . There was negligible change in average supply current after testing, indicating no permanent damage was incurred. Some spiking of the supply current was observed, but this did not appreciably affect the level of the driver outputs. Numerous short ( $< 500 \text{ ns}$ ) low-high-low transients were observed on the outputs

of the C and D drivers. The cross section of the device was computed by dividing the total number of transients observed for all five devices by the total effective fluence seen by all five devices. Therefore, cross section = total number of transients / total effective fluence =  $444 / 5 \times 10^6 \text{ ions/cm}^2 = 8.88 \times 10^{-5} \text{ cm}^2$ .

### **Summary (Non-neutron Irradiated Devices)**

When tested with Au ions at an LET = 85.4 MeV/mg/cm<sup>2</sup>, V<sub>IN</sub> = 15 V, T<sub>C</sub> = 25°C, the ISL7457SRH was found to be vulnerable to SEL/SEB.

When tested with Ag ions at an LET = 42.2 MeV/mg/cm<sup>2</sup>, V<sub>IN</sub> = 15 V, T<sub>C</sub> = 25°C, the ISL7457SRH was found to be immune to SEL/SEB. SET behavior consisted of numerous low-high-low transients at the outputs of the C and D drivers that lasted for < 500ns. The capture cross section was computed to be  $3.01 \times 10^{-6} \text{ cm}^2$ .

### **Summary (Neutron Irradiated Devices)**

When tested with Ag ions at an LET = 64.8 MeV/mg/cm<sup>2</sup>, V<sub>IN</sub> = 14.7 V, T<sub>C</sub> = 85°C, the ISL7457SRH was found to be vulnerable to SEL/SEB.

When tested with Ag ions at an LET = 64.8 MeV/mg/cm<sup>2</sup>, V<sub>IN</sub> = 14V, T<sub>C</sub> = 85°C, the ISL7457SRH was found to be vulnerable to SEL/SEB.

When tested with Ag ions at an LET = 86.4 MeV/mg/cm<sup>2</sup>, V<sub>IN</sub> = 6.1V, T<sub>C</sub> = 125°C, the ISL7457SRH was found to be immune to SEL/SEB. SET behavior consisted of numerous low-high-low transients at the outputs of the C and D drivers that lasted for < 500ns. The capture cross section was computed to be  $8.88 \times 10^{-5} \text{ cm}^2$ .

### **Appendix**

Figures 2 - 6 that follow show representative oscilloscope waveforms captured during the SEE testing.

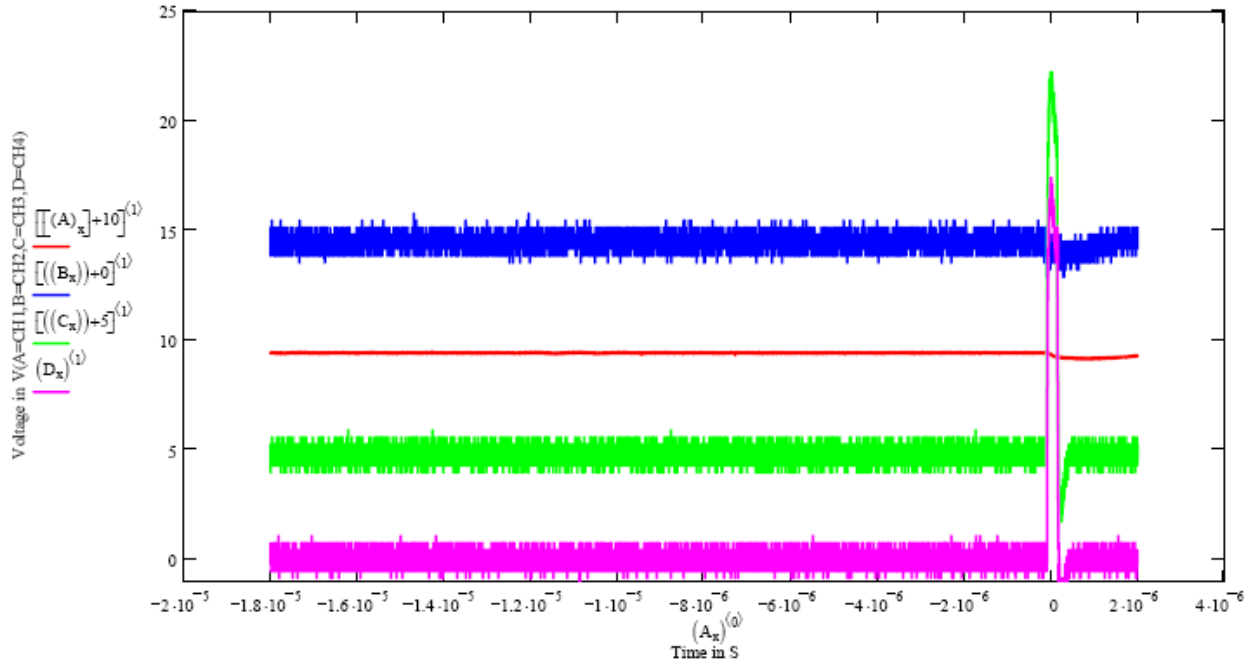

**Figure 2: Short duration (< 500 ns) low-high-low transients on OUTC and OUTD (Au Ions, LET = 85.4 MeV/mg/cm<sup>2</sup>, V<sub>IN</sub> = 15 V, T<sub>C</sub> = 25°C, Ax = V<sub>D1</sub>, Bx = OUTB, Cx = OUTC, Dx= OUTD)**

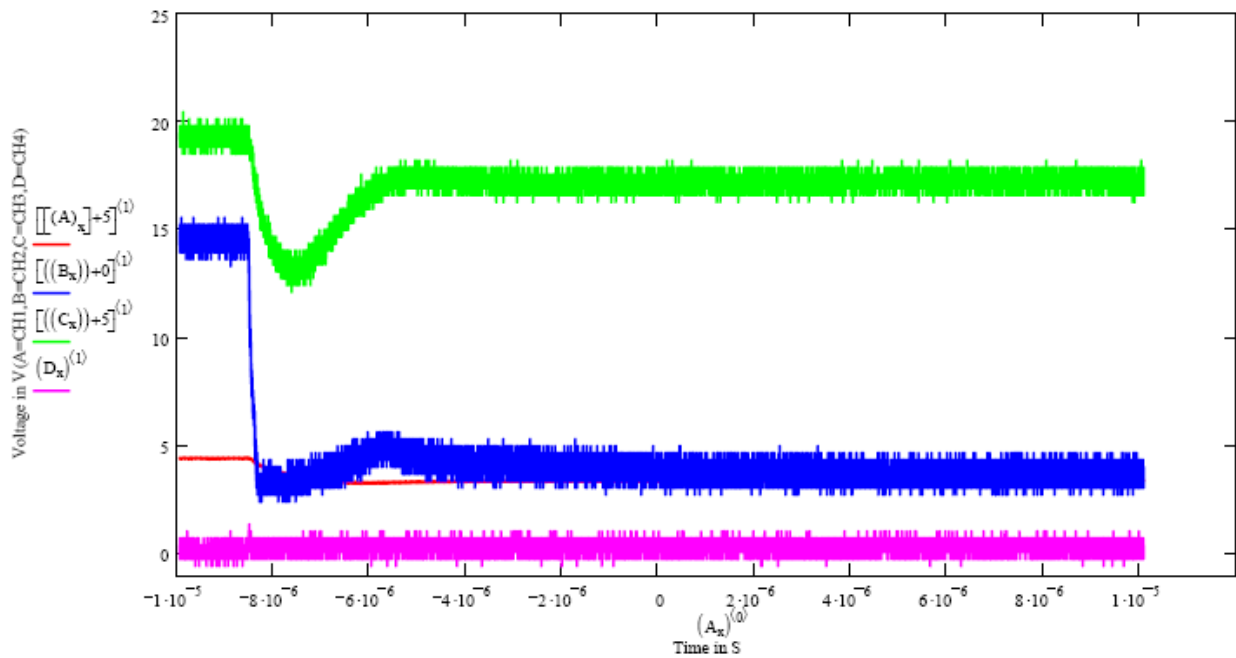

**Figure 3: Long Duration (> 18 us) high-low transient on OUTA (Au ions, LET = 85.4 MeV/mg/cm<sup>2</sup>, V<sub>IN</sub> = 15 V, T<sub>C</sub> = 25°C, Ax = V<sub>D1</sub>, Bx = OUTA, Cx = OUTB, Dx = OUTC)**

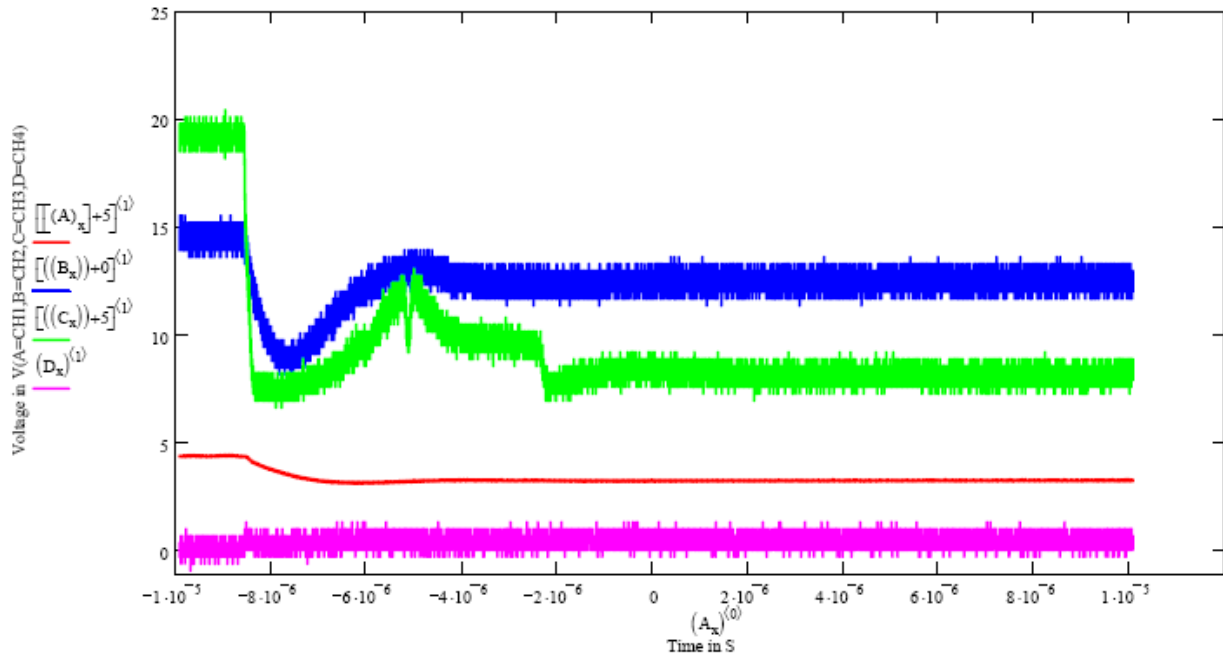

**Figure 4: Long Duration (> 18 us) high-low transient on OUTB (Au ions, LET = 85.4 MeV/mg/cm<sup>2</sup>, V<sub>IN</sub> = 15 V, T<sub>C</sub> = 25°C, Ax = V<sub>D1</sub>, Bx = OUTA, Cx = OUTB, Dx = OUTC)**

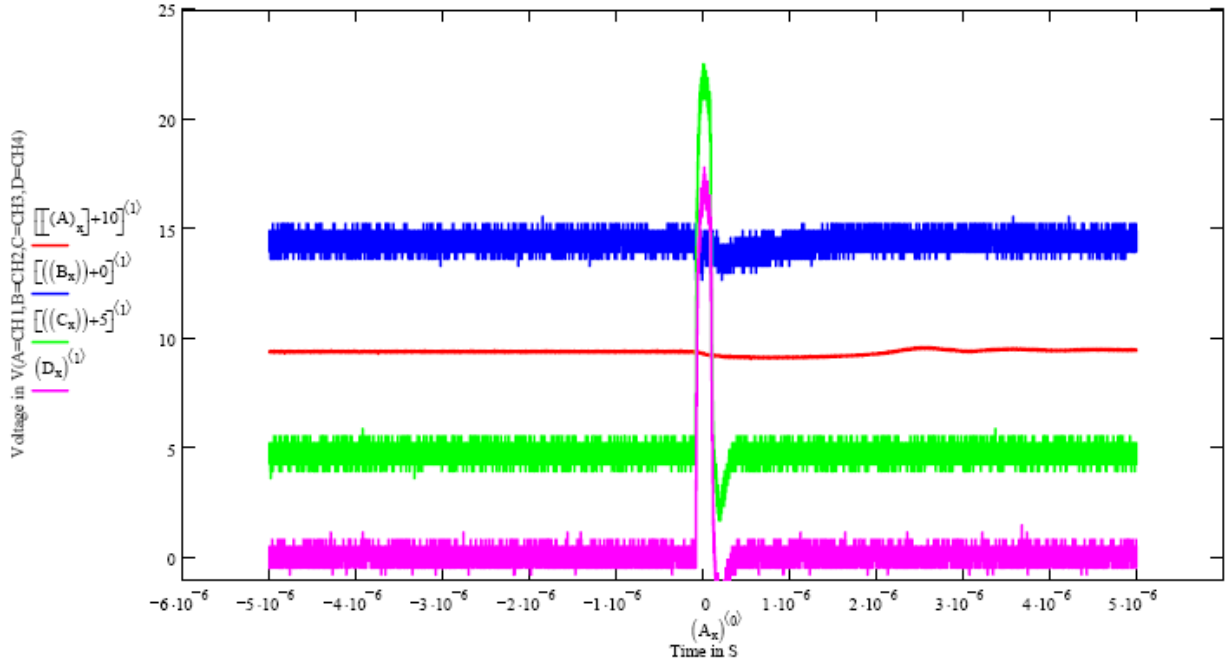

**Figure 5: Short duration (< 500 ns) low-high-low transients on OUTC and OUTD (Ag ions, LET = 42.2 MeV/mg/cm<sup>2</sup>, V<sub>IN</sub> = 15 V, T<sub>C</sub> = 25°C, Ax = V<sub>D1</sub>, Bx = OUTB, Cx = OUTC, Dx= OUTD)**

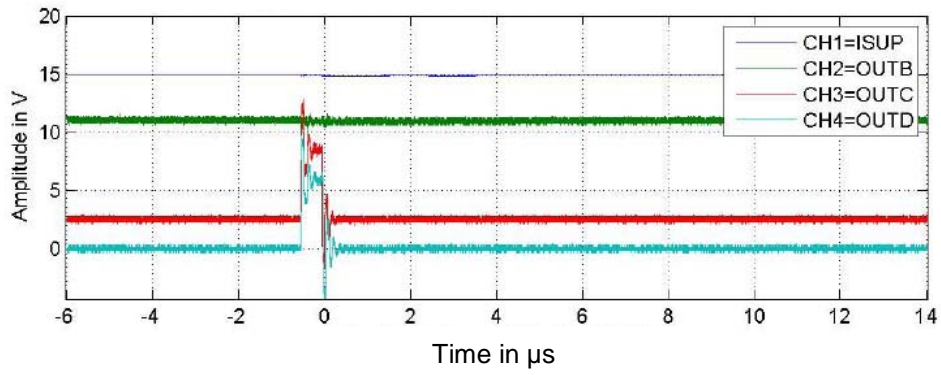

**Figure 6: Short duration (< 500 ns) low-high-low transients on OUTC and OUTD (Ag ions, LET = 86.4 MeV/mg/cm<sup>2</sup>, V<sub>IN</sub> = 6.1 V, T<sub>C</sub> = 125°C)**