

Introduction

The intense, heavy ion environment encountered in space applications can cause a variety of effects in electronic circuitry, including single event transient (SET), single event latchup (SEL) and single event burnout (SEB). These single event effects (SEE) can lead to system-level performance issues including degradation, disruption and destruction. For predictable and reliable space system operation, individual electronic components should be characterized to determine their SEE response. This report discusses the results of SEE testing performed on the ISL72991RH Adjustable Voltage Regulator.

Product Description

The ISL72991RH is a monolithic, linear voltage regulator fabricated using the Intersil Corporation dielectrically isolated (DI), radiation-hardened silicon gate (RSG) process. This process is optimized for power management functions and features complementary high-voltage MOS and bipolar devices as well as various passive components. The ISL72991RH is hardened to a total ionizing dose of 300krads(Si).

Functionally, the ISL72991RH is a low-drop-out (LDO), adjustable, series-pass, negative voltage regulator that is equivalent to commercial 2991 types, except that it features an adjustable, rather than a fixed, output current limit. The device is designed to provide a regulated output voltage from -2.25V to -26V at an output current ranging from 3mA to 1A.

SEE Test Objectives

The ISL72991RH was tested for SEE to verify its immunity to SEL/SEB and to characterize its SET performance under various bias and load conditions.

SEE Test Procedure

Testing was conducted at the Texas A&M University Cyclotron Institute heavy ion facility. This facility is coupled to a K500 super-conducting cyclotron and is capable of generating a wide range of test particles with the various energy, fluence and flux levels needed for advanced radiation testing.

Diagram 1 shows the ISL72991RH SEE test fixture schematic. The fixture enables adjustment of input voltage, output voltage, output load and output capacitance. R3 was adjusted to set the output voltage at precisely -5V for all tests. R1 was selected to program the typical output current limit threshold to 1A. Closing SW1 parallels a 22uF capacitor with the fixed 22uF output capacitor. Closing SW2 increases the output load from 3.75mA to approximately 500mA. An oscilloscope was connected to VIN/VOUT in order to record the

input/output waveforms, and a counter was connected to VOUT to record the number of transients. All input/output capacitors were wet tantalum (CLR) types.

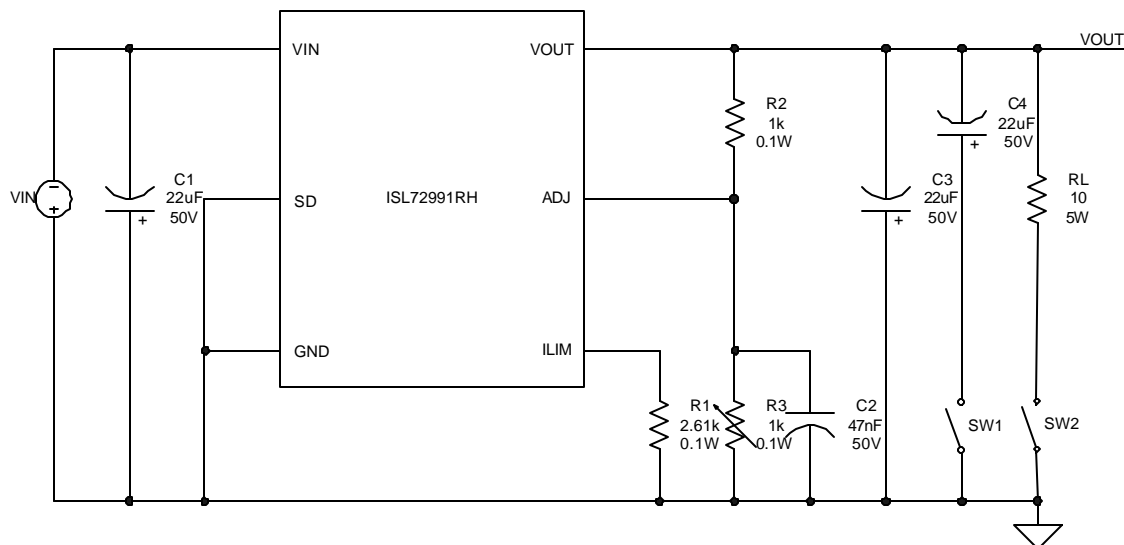

Diagram 1: ISL72991RH SEE Test Fixture Schematic

Table 1 shows the characteristics of the various beams used for SEE testing.

Beam Type	Incident Angle (°)	LET (MeV/mg/cm ²)	Fluence (p/cm ²)	Flux (p/cm ² /s)
Gold	0	87.4	1x10 ⁷	Various
Krypton	0	36	1x10 ⁷	Various
Argon	0	15	1x10 ⁷	Various

Table 1: Beam Type and Characteristics

Table 2 shows the test number, the beam type, the test conditions and the transient count recorded for each of the SEE tests. A transient was defined to be a change in output voltage that exceeded 2% of the nominal output voltage. With the output set to -5V, a transient corresponded to a 100mV magnitude increase in the output voltage.

Test Number	Beam Type	Test Conditions	Transient Count
1	Gold	Vin=-30V; Vout=-5V; Iout=3.75mA; Cout=22uF	74614
2	Gold	Vin=-30V; Vout=-5V; Iout=3.75mA; Cout=44uF	74523
3	Gold	Vin=-10V; Vout=-5V; Iout=3.75mA; Cout=22uF	53548
4	Gold	Vin=-10V; Vout=-5V; Iout=3.75mA; Cout=44uF	54660
5	Gold	Vin=-10V; Vout=-5V; Iout=500mA; Cout=22uF	52919
6	Gold	Vin=-10V; Vout=-5V; Iout=500mA; Cout=44uF	55324
7	Gold	Vin=-7V; Vout=-5V; Iout=3.75mA; Cout=22uF	17024
8	Gold	Vin=-7V; Vout=-5V; Iout=3.75mA; Cout=44uF	18564

9	Gold	Vin=-7V; Vout=-5V; Iout=500mA; Cout=22uF	44653
10	Gold	Vin=-7V; Vout=-5V; Iout=500mA; Cout=44uF	18314
11	Gold	Vin=-6V; Vout=-5V; Iout=3.75mA; Cout=22uF	8012
12	Gold	Vin=-6V; Vout=-5V; Iout=3.75mA; Cout=44uF	5137
13	Gold	Vin=-6V; Vout=-5V; Iout=500mA; Cout=22uF	28671
14	Gold	Vin=-6V; Vout=-5V; Iout=500mA; Cout=44uF	9504
15	Krypton	Vin=-10V; Vout=-5V; Iout=3.75mA; Cout=22uF	13658
16	Krypton	Vin=-10V; Vout=-5V; Iout=3.75mA; Cout=44uF	11304
17	Krypton	Vin=-10V; Vout=-5V; Iout=500mA; Cout=22uF	47373
18	Krypton	Vin=-10V; Vout=-5V; Iout=500mA; Cout=44uF	17994
19	Krypton	Vin=-7V; Vout=-5V; Iout=3.75mA; Cout=22uF	5949
20	Krypton	Vin=-7V; Vout=-5V; Iout=3.75mA; Cout=44uF	8532
21	Krypton	Vin=-7V; Vout=-5V; Iout=500mA; Cout=22uF	36253
22	Krypton	Vin=-7V; Vout=-5V; Iout=500mA; Cout=44uF	8389
23	Krypton	Vin=-6V; Vout=-5V; Iout=3.75mA; Cout=22uF	6120
24	Krypton	Vin=-6V; Vout=-5V; Iout=3.75mA; Cout=44uF	3646
25	Krypton	Vin=-6V; Vout=-5V; Iout=500mA; Cout=22uF	11746
26	Krypton	Vin=-6V; Vout=-5V; Iout=500mA; Cout=44uF	3169
27	Argon	Vin=-10V; Vout=-5V; Iout=3.75mA; Cout=22uF	0
28	Argon	Vin=-10V; Vout=-5V; Iout=3.75mA; Cout=44uF	0
29	Argon	Vin=-10V; Vout=-5V; Iout=500mA; Cout=22uF	0
30	Argon	Vin=-10V; Vout=-5V; Iout=500mA; Cout=44uF	0
31	Argon	Vin=-7V; Vout=-5V; Iout=3.75mA; Cout=22uF	0
32	Argon	Vin=-7V; Vout=-5V; Iout=3.75mA; Cout=44uF	0
33	Argon	Vin=-7V; Vout=-5V; Iout=500mA; Cout=22uF	0
34	Argon	Vin=-7V; Vout=-5V; Iout=500mA; Cout=44uF	0
35	Argon	Vin=-6V; Vout=-5V; Iout=3.75mA; Cout=22uF	0
36	Argon	Vin=-6V; Vout=-5V; Iout=3.75mA; Cout=44uF	0
37	Argon	Vin=-6V; Vout=-5V; Iout=500mA; Cout=22uF	0
38	Argon	Vin=-6V; Vout=-5V; Iout=500mA; Cout=44uF	0

Table 2: SEE Tests

SEL/SEB Testing

The goal of SEL/SEB testing was to apply the highest energy particles to the regulator under worst-case bias conditions to maximize the chance of latchup or burnout. Consequently, gold ions with a Linear Energy Transfer (LET) of 87.4MeV/mg/cm² and a fluence of 1x10⁷ p/cm² were used. Test #1 (Vin=-30V; Vout=-5V; Iout=3.75mA; Cout=22uF) provided the most transients (74,614) for a cross section of 7.46x10⁻³cm². Worst-case negative output excursions were observed to exceed -7V and worst-case positive output excursions increased the output to about -3.8V. Duration of all transients was less than 1us. Test #2 (Vin=-30V; Vout=-5V; Iout=3.75mA; Cout=44uF) added an additional 22uF output capacitor, which reduced the transient count to 74,523 and the cross section to 7.45x10⁻³cm². This

was expected since additional capacitance lowers the output impedance and requires more energy to generate output transients. But it was interesting to note that while output capacitance was doubled, the number of upsets fell by a scant 0.12%. Worst-case negative output excursions still exceeded -7V and worst-case positive output excursions were unchanged at -3.8V. Duration of all transients was also less than 1 μ s. Figures 1-2, corresponding to tests #1-2, show the input/output waveforms of the regulator during SEL/SEB testing. No evidence of latchup or burnout was observed. The upper trace is input voltage (channel 1) and the lower trace is output voltage (channel 3).

SET Testing

The goal of SET testing was to characterize the performance of the regulator under real-world bias and load conditions when subjected to the beams shown in Table 1. In particular, the effect of input voltage, output capacitance and output load on the number and magnitude of transients was desired.

A total of 12 tests were conducted using each of the ion species. Input voltage was adjusted to -10V, -7V and -6V, output load was varied from 3.75mA to 500mA and output capacitance was varied from 22 μ F to 44 μ F.

Gold Ion SET Testing

Transient counts ranged from 54,660 for test #4 ($V_{in}=-10V$; $V_{out}=-5V$; $I_{out}=3.75mA$; $C_{out}=44\mu F$) to 5137 for test #12 ($V_{in}=-6V$; $V_{out}=-5V$; $I_{out}=3.75mA$; $C_{out}=44\mu F$). Negative excursions of the output voltage ranged from about 1.3V for test #3 ($V_{in}=-10V$; $V_{out}=-5V$; $I_{out}=3.75mA$; $C_{out}=22\mu F$) to about 300mV for test #13 ($V_{in}=-6V$; $V_{out}=-5V$; $I_{out}=500mA$; $C_{out}=22\mu F$) and test #14 ($V_{in}=-6V$; $V_{out}=-5V$; $I_{out}=500mA$; $C_{out}=44\mu F$). Positive excursions of the output voltage ranged from almost 1V for test #5 ($V_{in}=-10V$; $V_{out}=-5V$; $I_{out}=500mA$; $C_{out}=22\mu F$) to about 200mV for test #13 ($V_{in}=-6V$; $V_{out}=-5V$; $I_{out}=500mA$; $C_{out}=22\mu F$) and test #14 ($V_{in}=-6V$; $V_{out}=-5V$; $I_{out}=500mA$; $C_{out}=44\mu F$).

A certain trend was noted as input voltage was varied. With output capacitance and output load fixed, reducing the input voltage from -10V to -6V dramatically lowered the total transient count in all test cases. This was expected since the highly energetic particles induce charge in the DI island containing the series-pass transistor, tending to turn it on. Since the series-pass transistor connects input to output, if the input voltage is smaller in magnitude, less is available to be conducted to the output.

No clear relationship could be established regarding the effect of output capacitance on the transient count for a fixed input voltage and output load. In some instances when the output capacitance was doubled from 22 μ F to 44 μ F, the transient count decreased significantly (Tests #9 and #10, #11 and #12, #13 and #14). This was the expected effect since doubling the output capacitance lowers the output impedance, which should make it more difficult to generate output transients. In other instances, the transient count actually increased slightly when the output capacitance was doubled (Tests #3 and #4, #5 and #6, #7 and #8).

Similarly, no clear relationship could be established regarding the effect of output load on the transient count for a fixed input voltage and output capacitance. In some cases when the output capacitance was increased from 3.75mA to 500mA, the transient count decreased slightly (Tests #3 and #5, #8 and #10). This was the expected effect since increasing the load, like doubling the output capacitance, lowers the output impedance, which should make it more difficult to produce output transients. In other cases increasing the load slightly increased the transient count (Tests #4 and #6) or significantly increased the transient count (Tests #7 and #9, #11 and #13, #12 and #14).

Decreasing the input voltage visibly reduced the magnitude of the output transients. However, doubling the output capacitance or increasing the output load each had more subtle effects that resulted in either slight decreases or increases in the magnitude of the output transients.

Figures 3-14 correspond to tests #3-14 and show the input/output waveforms of the regulator during gold ion SET testing. The upper trace is input voltage (channel 1) and the lower trace is output voltage (channel 3) for all figures. Since transients in excess of the 100mV threshold were recorded for all tests using gold ions, testing was continued using lower energy krypton ions with an LET of 36MeV/mg/cm².

Krypton Ion SET Testing

Transient counts ranged from 47,373 for test #17 (Vin=-10V; Vout=-5V; Iout=500mA; Cout=22uF) to 3169 for test #26 (Vin=-6V; Vout=-5V; Iout=500mA; Cout=44uF). Negative excursions of the output voltage ranged from about 900mV for test #17 (Vin=-10V; Vout=-5V; Iout=500mA; Cout=22uF) to about 150mV for test #26 (Vin=-6V; Vout=-5V; Iout=500mA; Cout=44uF). Positive excursions of the output voltage ranged from almost 800mV for test #17 (Vin=-10V; Vout=-5V; Iout=500mA; Cout=22uF) to about 300mV for test #26 (Vin=-6V; Vout=-5V; Iout=500mA; Cout=44uF).

A similar trend was noted regarding the effect of input voltage on the transient count. Lowering the input voltage substantially reduced the transient count for a given output capacitance and output load, except for tests #19 and #23, where it slightly increased the transient count. Doubling the output capacitance substantially reduced the transient count for a given input voltage and output load, except for tests #19 and #20, where there was a substantial increase in the transient count. Increasing the load for a fixed input voltage and output capacitance showed mixed results. In some instances the transient count decreased (Tests #20 and #22, #24 and #26), but in others it increased (Tests #15 and #17, #16 and #18, #19 and #21, #23 and #25).

Figures 15-26 correspond to tests #15-26 and show the input/output waveforms of the regulator during krypton ion SET testing. The upper trace is input voltage (channel 1) and the lower trace is output voltage (channel 3) for all figures. Since transients in excess of the 100mV threshold were recorded for all tests using krypton ions, testing was continued using lower energy argon ions with an LET of 15MeV/mg/cm².

Argon Ion SET Testing

No transient counts were recorded for any of the tests using argon ions. However, Figures 29, 30-35 and 37 showed output excursions that appeared to exceed the 100mV transient threshold. To resolve the discrepancy between the oscilloscope and the counter, the latter was recalibrated and test #29 was run again. The oscilloscope showed virtually the same waveforms and again, no counts were recorded. Single sweeps using the oscilloscope were then conducted with channel 3 ac-coupled. This showed that the output voltage consists of a series of damped, quasi-sinusoidal signals having a peak amplitude of 170mV at a frequency of about 5MHz, which is approaching the 10MHz band width of the counter. Figure 39 shows a representative single sweep conducted using test #29 conditions. Further testing using a function generator confirmed that the counter would not record counts for input frequencies above 3MHz. Consequently, the counts recorded in Table 2 may not be completely accurate for any output frequency content above 3MHz.

Figures 27-38 correspond to tests #27-38 and show the input/output waveforms of the regulator during argon ion SET testing. The upper trace is input voltage (channel 1) and the lower trace is output voltage (channel 3) for all figures. Since several test cases were found where transients did not exceed the 100mV threshold, SET testing was concluded.

Conclusions

The Intersil ISL72991RH adjustable voltage regulator was tested for SEE under various bias and load conditions using a variety of heavy ions. As expected, the regulator was shown to be SEL/SEB immune when exposed to gold ions at an LET of 87.4MeV/mg/cm^2 under worst-case bias conditions. Transients in excess of 100mV were observed during all tests using gold ions at an LET of 87.4MeV/mg/cm^2 and krypton ions at an LET of 36MeV/mg/cm^2 . With argon ions at an LET of 15MeV/mg/cm^2 , no transients greater than 100mV occurred during tests #27, #28, #36 and #38. Generally speaking, the transient count was shown to drop as input voltage decreased. The relationship of output capacitance and output load to transient count was mixed.

If larger output transients can be tolerated, the ISL72991RH can be used in the presence of higher energy krypton ($\text{LET}=36\text{MeV/mg/cm}^2$) and gold ($\text{LET}=87.4\text{MeV/mg/cm}^2$) ions. Based on the figures, no transients in excess of 900mV were observed during krypton ion testing. No transients in excess of 900mV were observed during gold ion testing as long as input voltage was -7V or less.

Appendix

Figures 1-38 that follow correspond to tests #1-38 and show the input/output waveforms of the regulator during SEE testing. The upper trace is input voltage (channel 1) and the lower trace is output voltage (channel 3) for all figures. Figure 39 shows the results of a single sweep output recorded during test #29. The upper trace is output voltage (Channel 3), which is ac-coupled and the lower trace is input voltage (Channel 1). Ground for all waveforms is indicated by the arrow on the left-hand side of each figure.

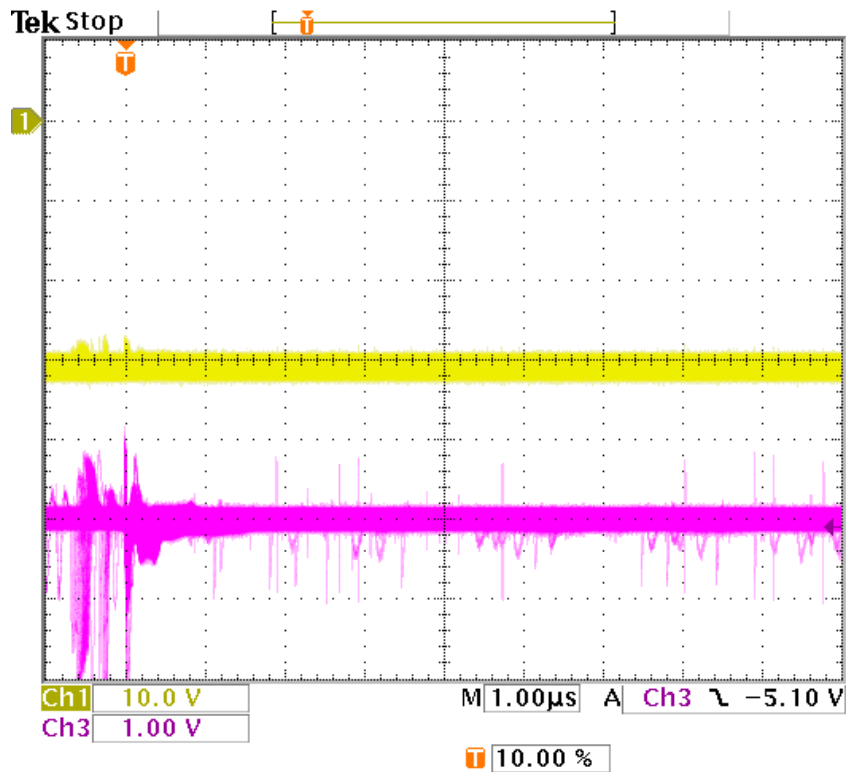

Figure 1: Test #1 Results ($V_{in}=30V$; $V_{out}=-5V$; $I_{out}=3.75mA$; $C_{out}=22\mu F$)

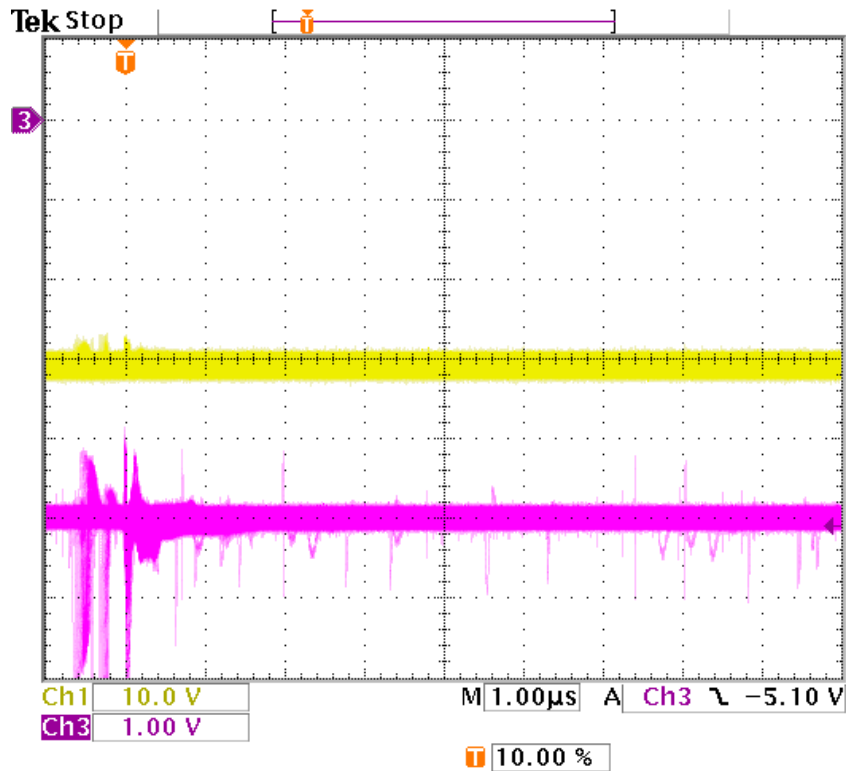

Figure 2: Test #2 Results ($V_{in}=30V$; $V_{out}=-5V$; $I_{out}=3.75mA$; $C_{out}=44\mu F$)

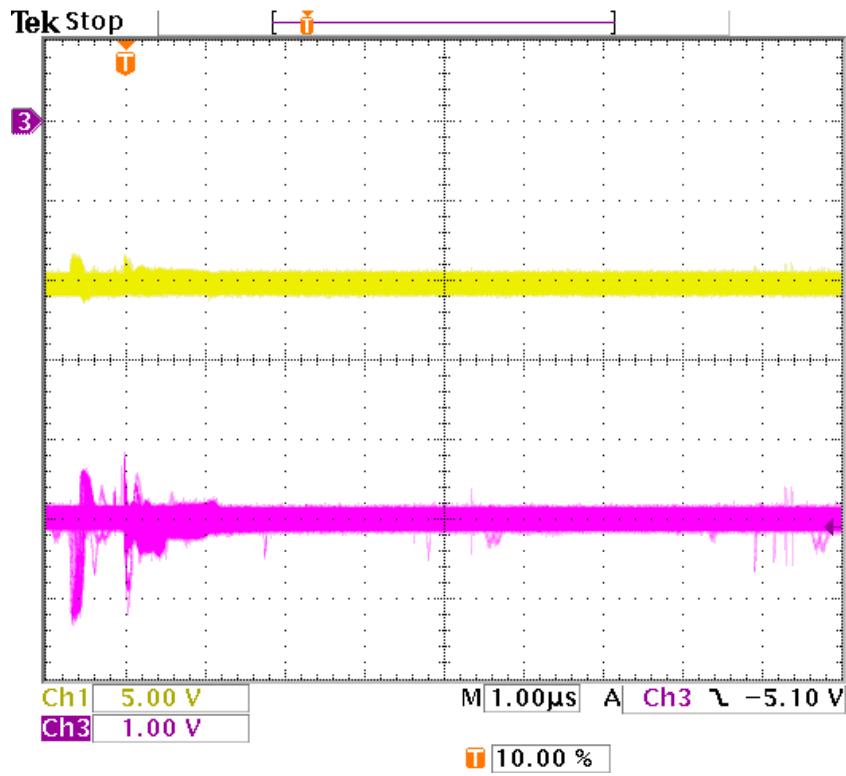

Figure 3: Test #3 Results ($V_{in}=-10V$; $V_{out}=-5V$; $I_{out}=3.75mA$; $C_{out}=22\mu F$)

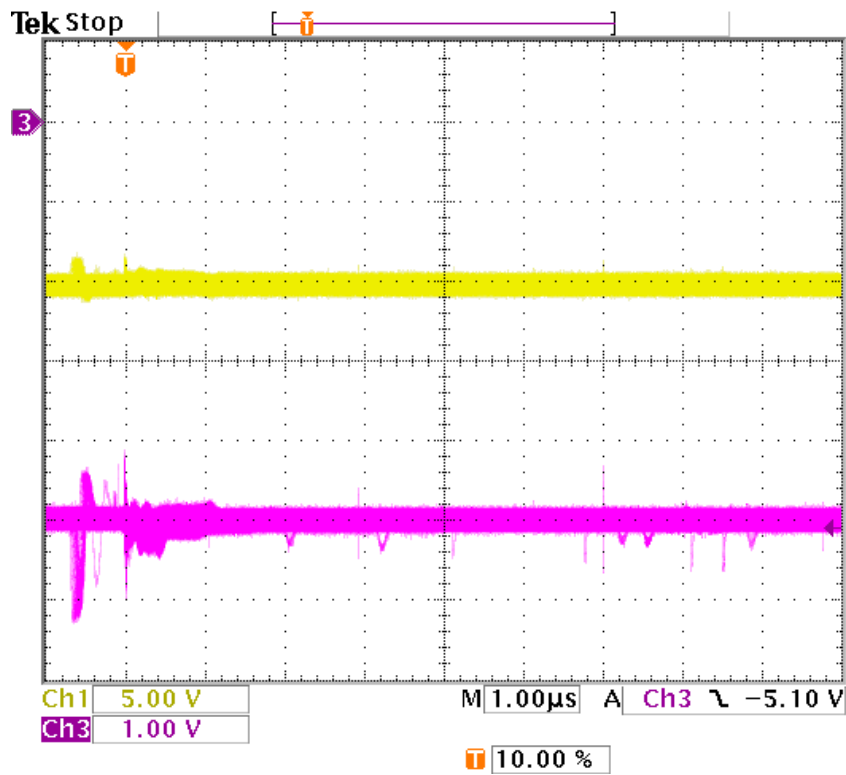

Figure 4: Test #4 Results ($V_{in}=-10V$; $V_{out}=-5V$; $I_{out}=3.75mA$; $C_{out}=44\mu F$)

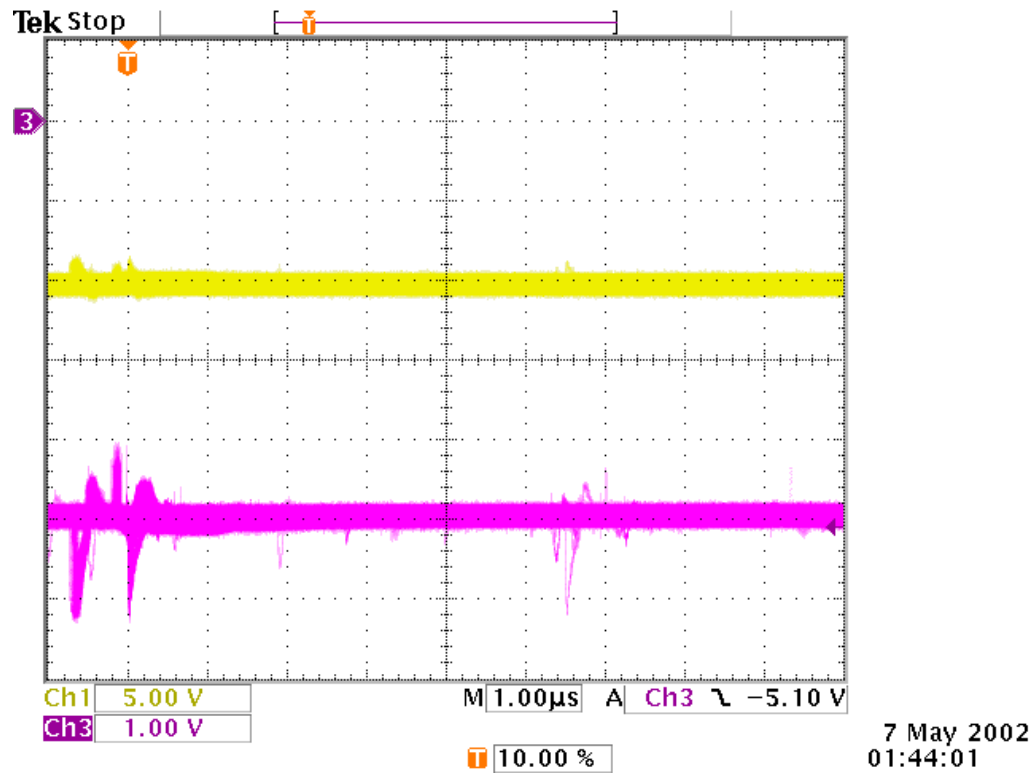

Figure 5: Test #5 Results ($V_{in}=-10V$; $V_{out}=-5V$; $I_{out}=500mA$; $C_{out}=22\mu F$)

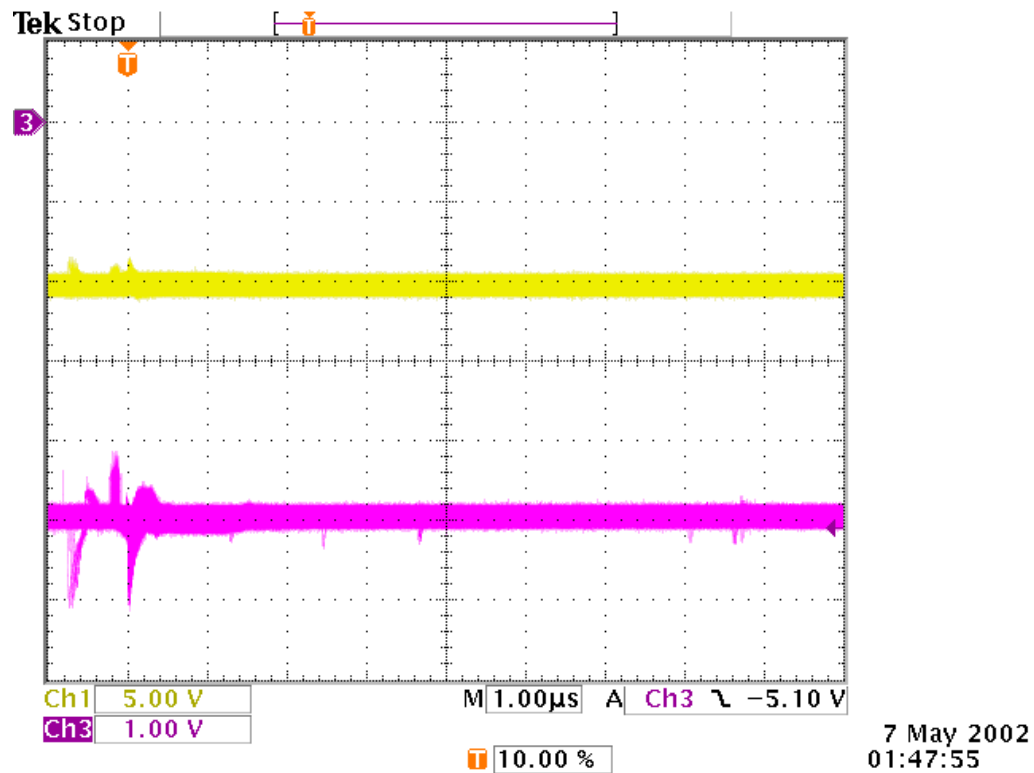

Figure 6: Test #6 Results ($V_{in}=-10V$; $V_{out}=-5V$; $I_{out}=500mA$; $C_{out}=44\mu F$)

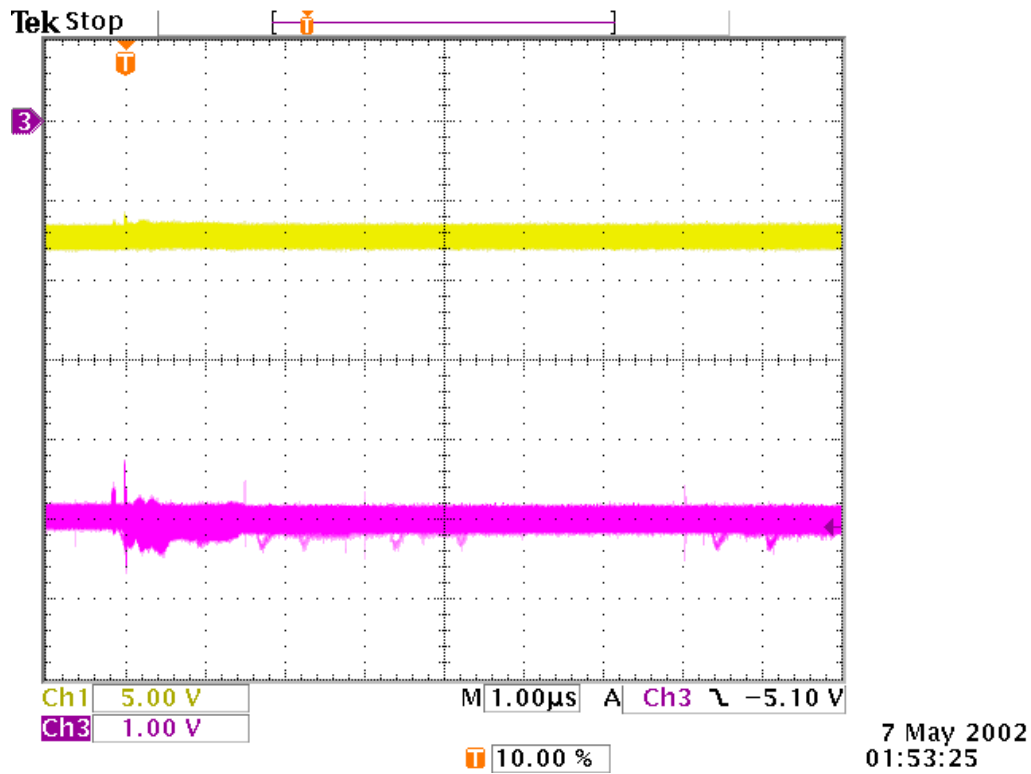

Figure 7: Test #7 Results ($V_{in}=-7V$; $V_{out}=-5V$; $I_{out}=3.75mA$; $C_{out}=22\mu F$)

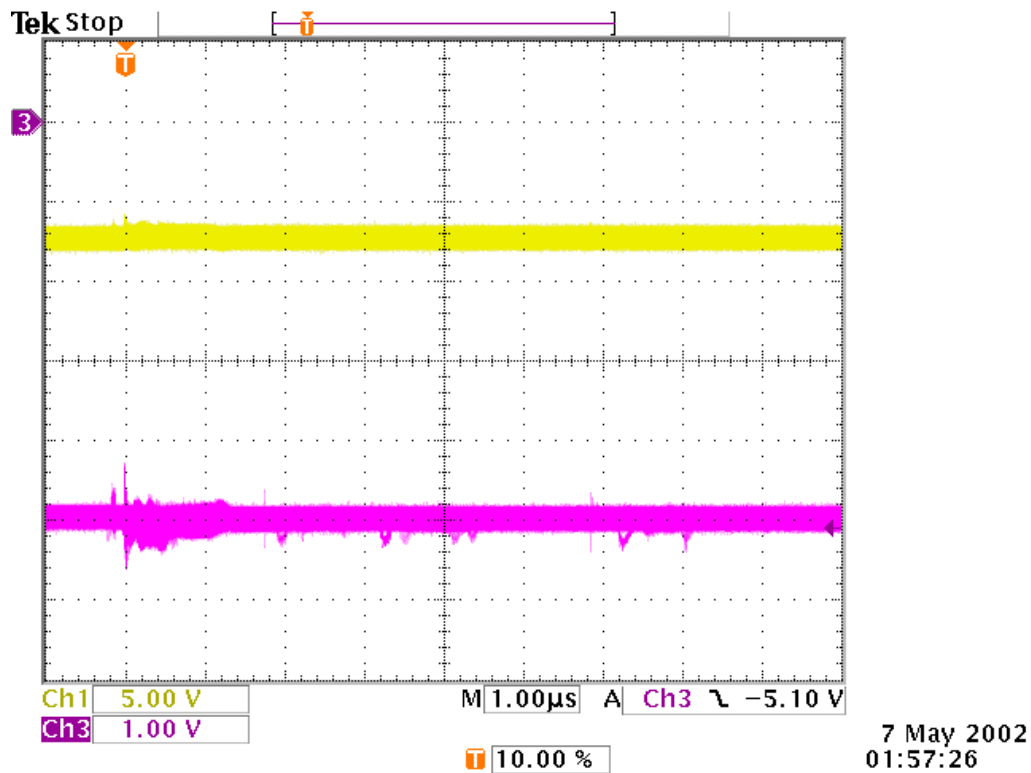

Figure 8: Test #8 Results ($V_{in}=-7V$; $V_{out}=-5V$; $I_{out}=3.75mA$; $C_{out}=44\mu F$)

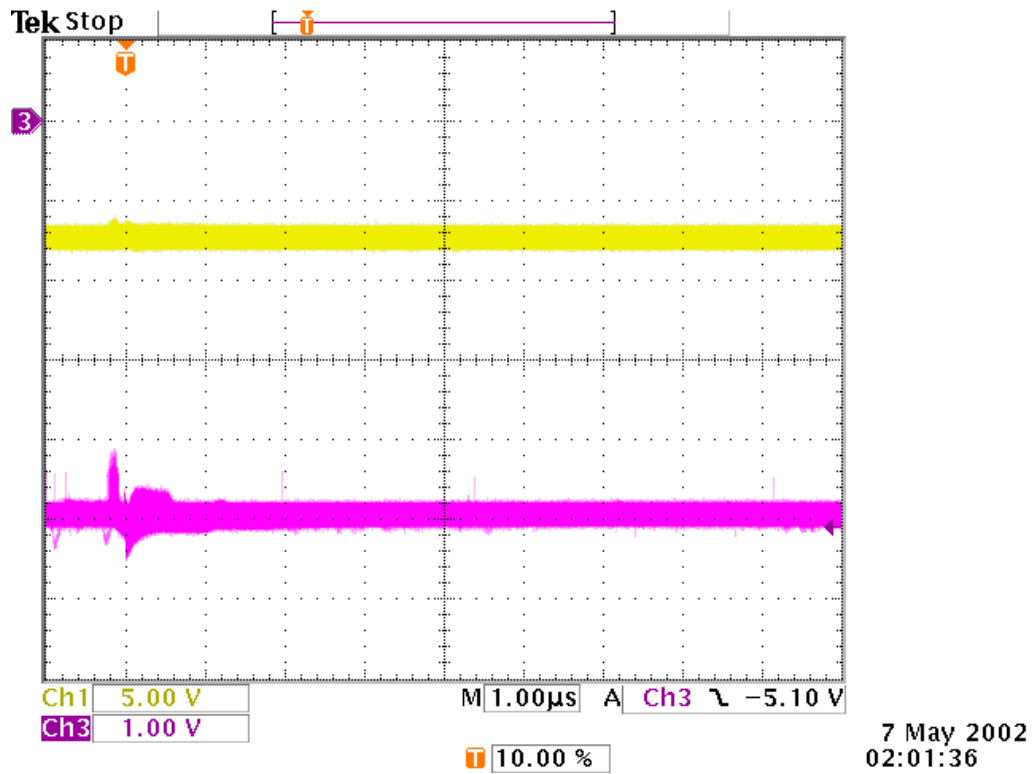

Figure 9: Test #9 Results ($V_{in}=-7V$; $V_{out}=-5V$; $I_{out}=500mA$; $C_{out}=22\mu F$)

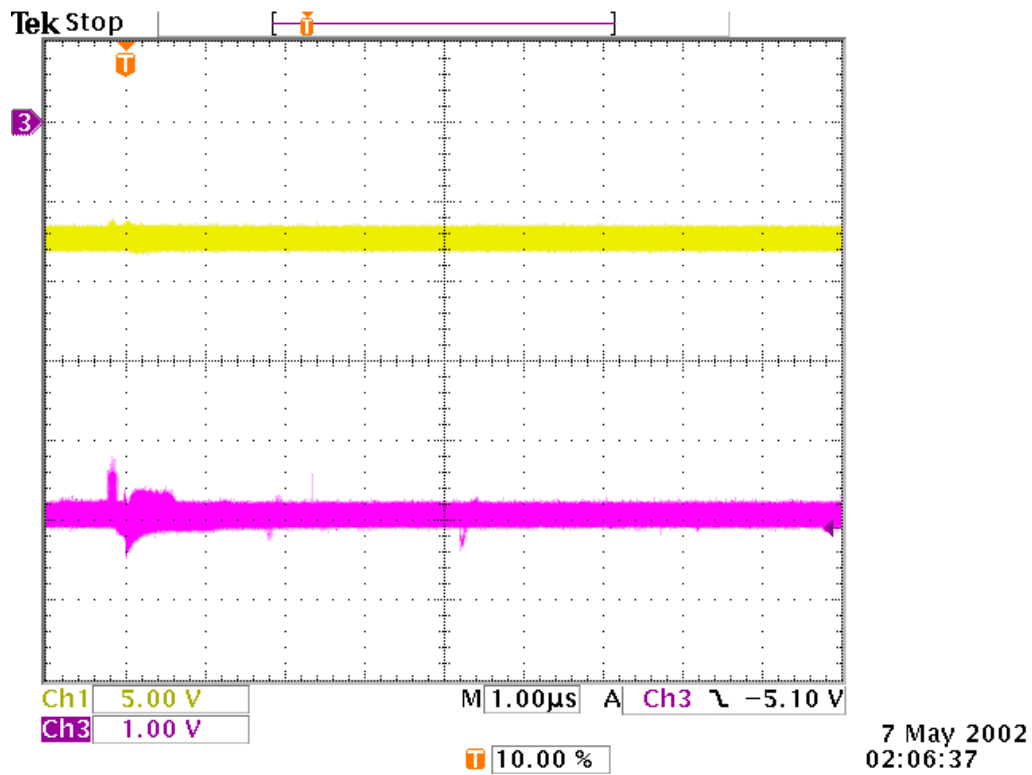

Figure 10: Test #10 Results ($V_{in}=-7V$; $V_{out}=-5V$; $I_{out}=500mA$; $C_{out}=44\mu F$)

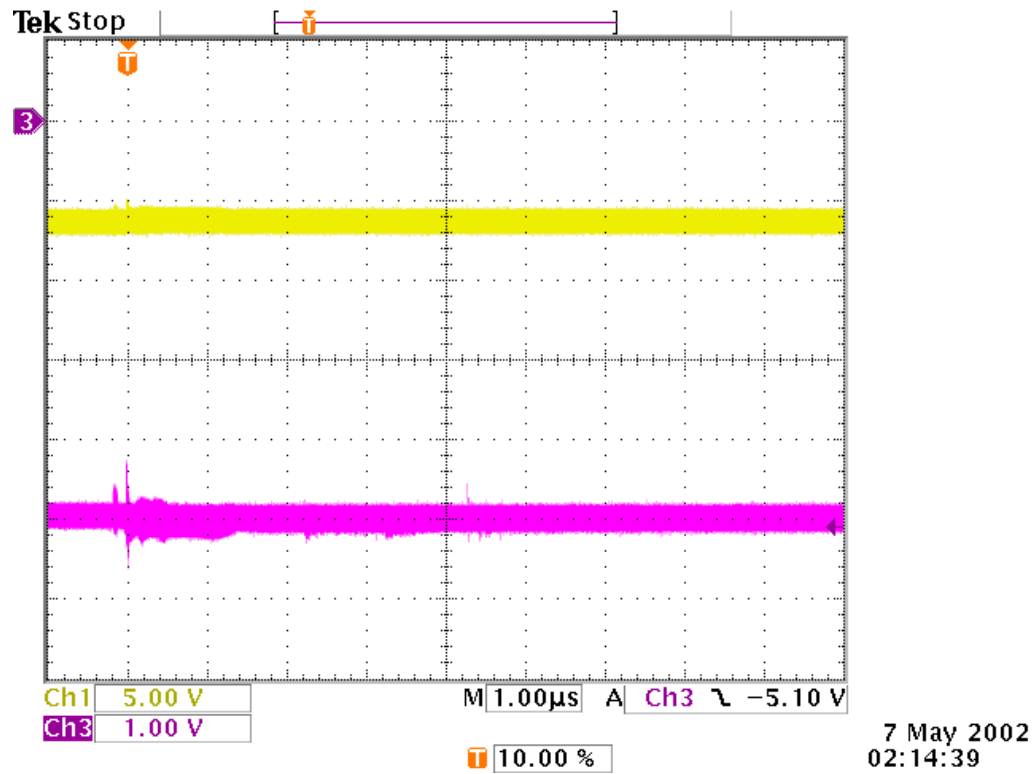

Figure 11: Test #11 Results ($V_{in}=6V$; $V_{out}=-5V$; $I_{out}=3.75mA$; $C_{out}=22\mu F$)

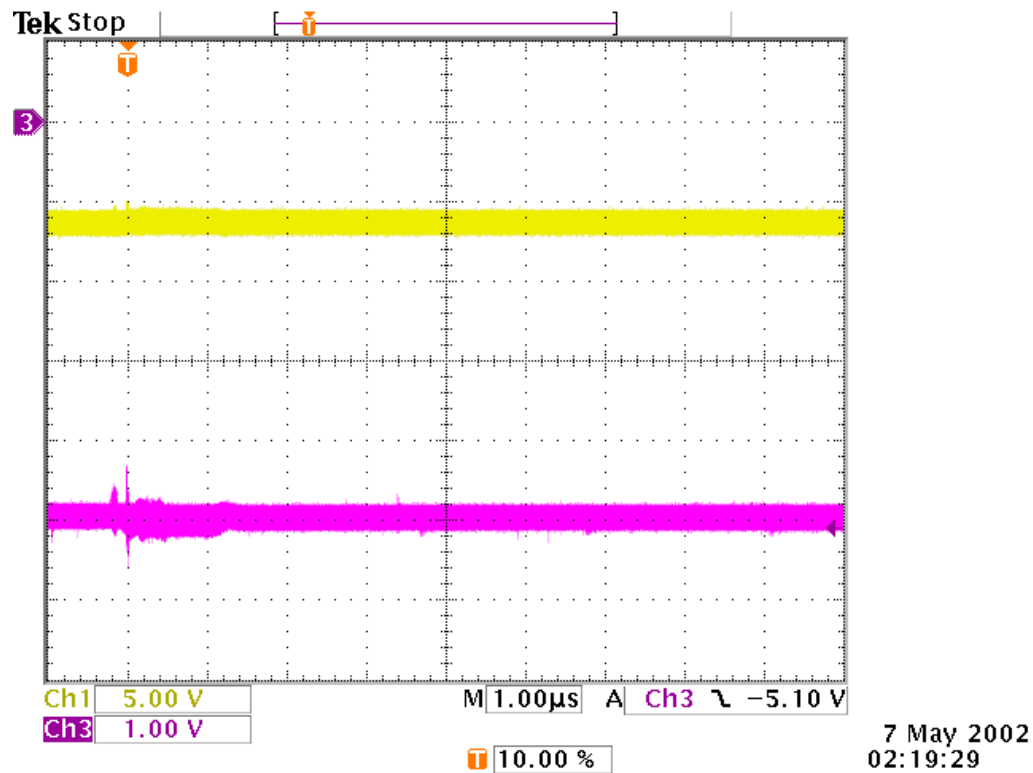

Figure 12: Test #12 Results ($V_{in}=6V$; $V_{out}=-5V$; $I_{out}=3.75mA$; $C_{out}=44\mu F$)

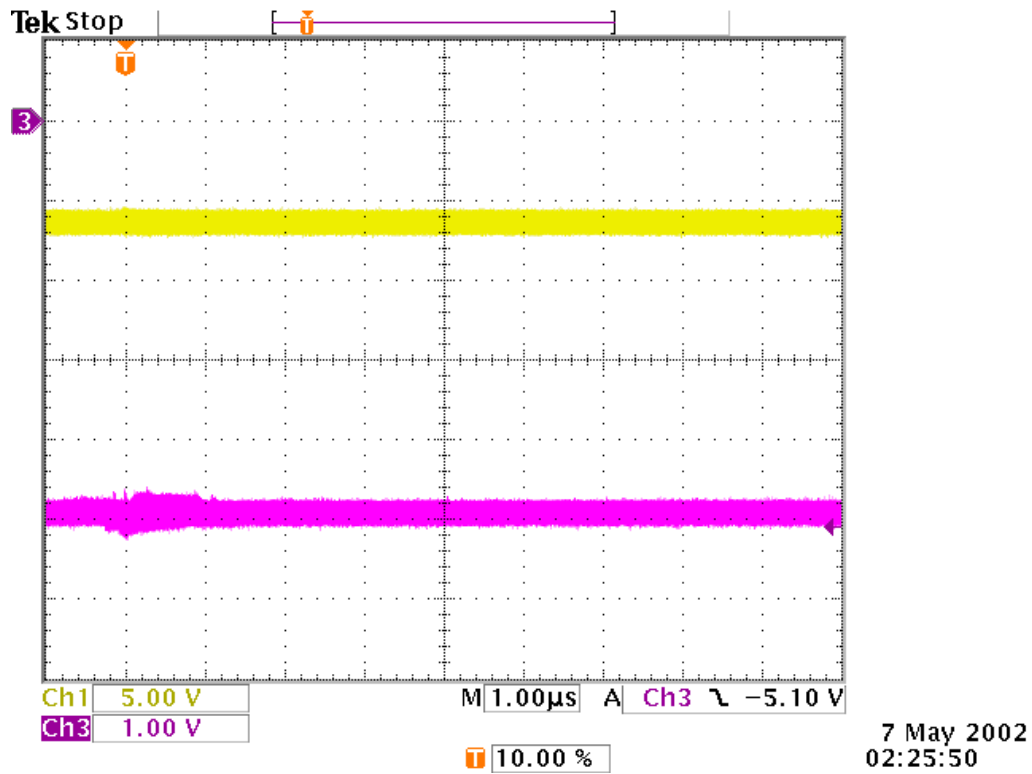

Figure 13: Test #13 Results ($V_{in}=6V$; $V_{out}=-5V$; $I_{out}=500mA$; $C_{out}=22\mu F$)

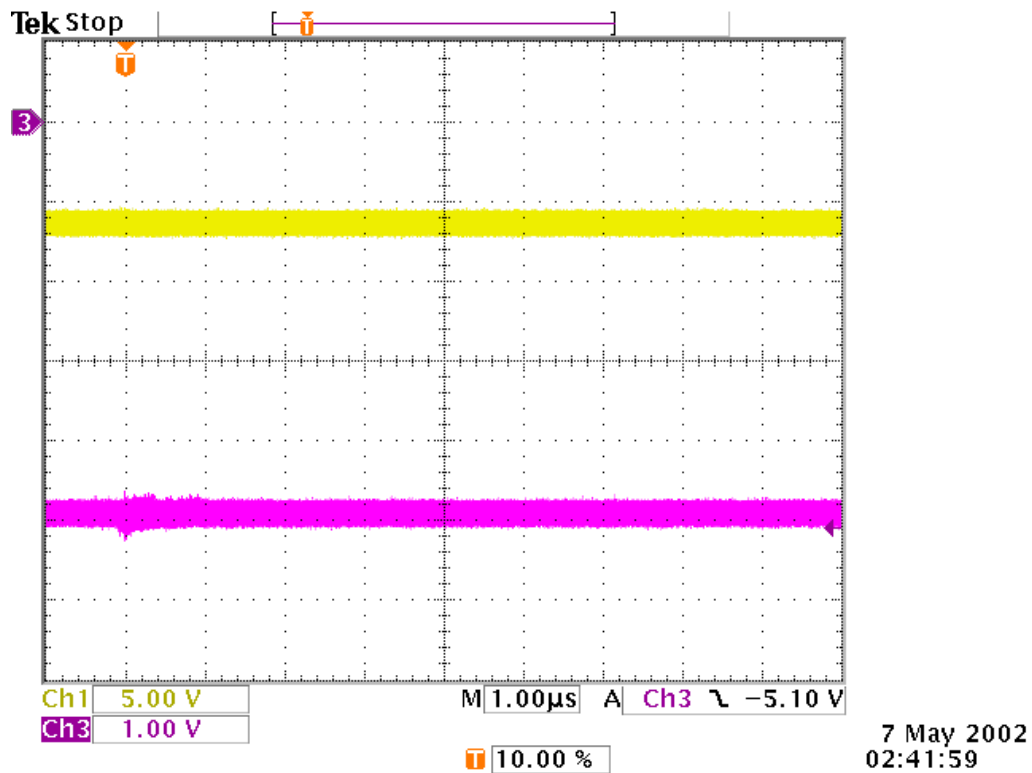

Figure 14: Test #14 Results ($V_{in}=6V$; $V_{out}=-5V$; $I_{out}=500mA$; $C_{out}=44\mu F$)

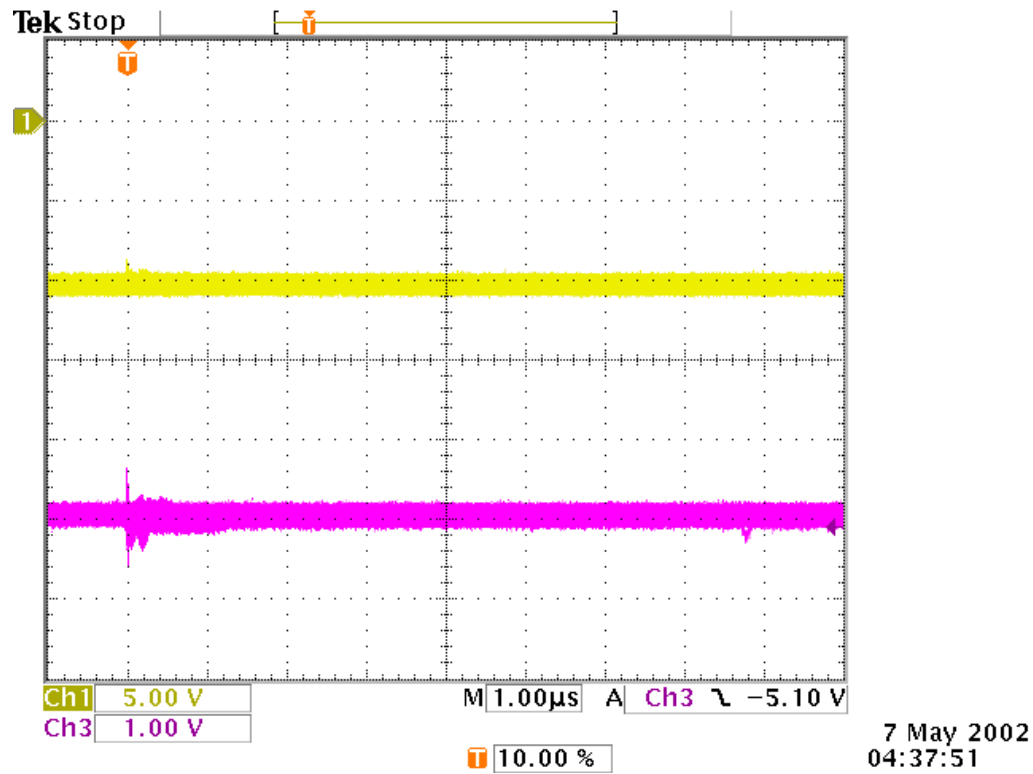

Figure 15: Test #15 Results ($V_{in}=-10V$; $V_{out}=-5V$; $I_{out}=3.75mA$; $C_{out}=22\mu F$)

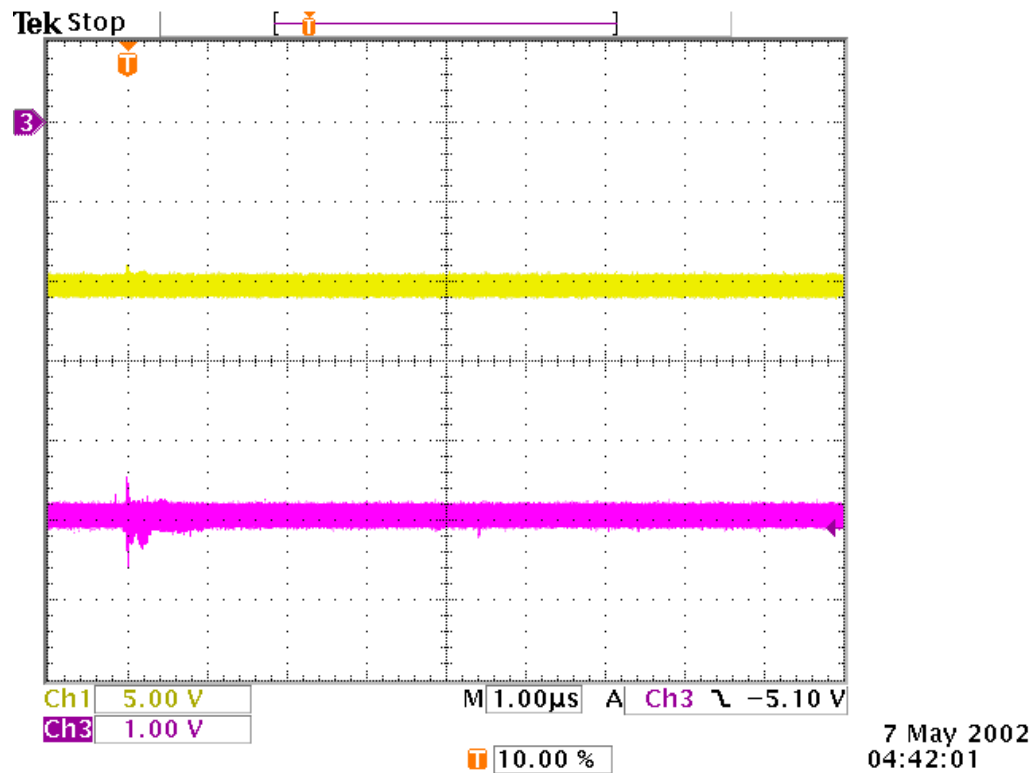

Figure 16: Test #16 Results ($V_{in}=-10V$; $V_{out}=-5V$; $I_{out}=3.75mA$; $C_{out}=44\mu F$)

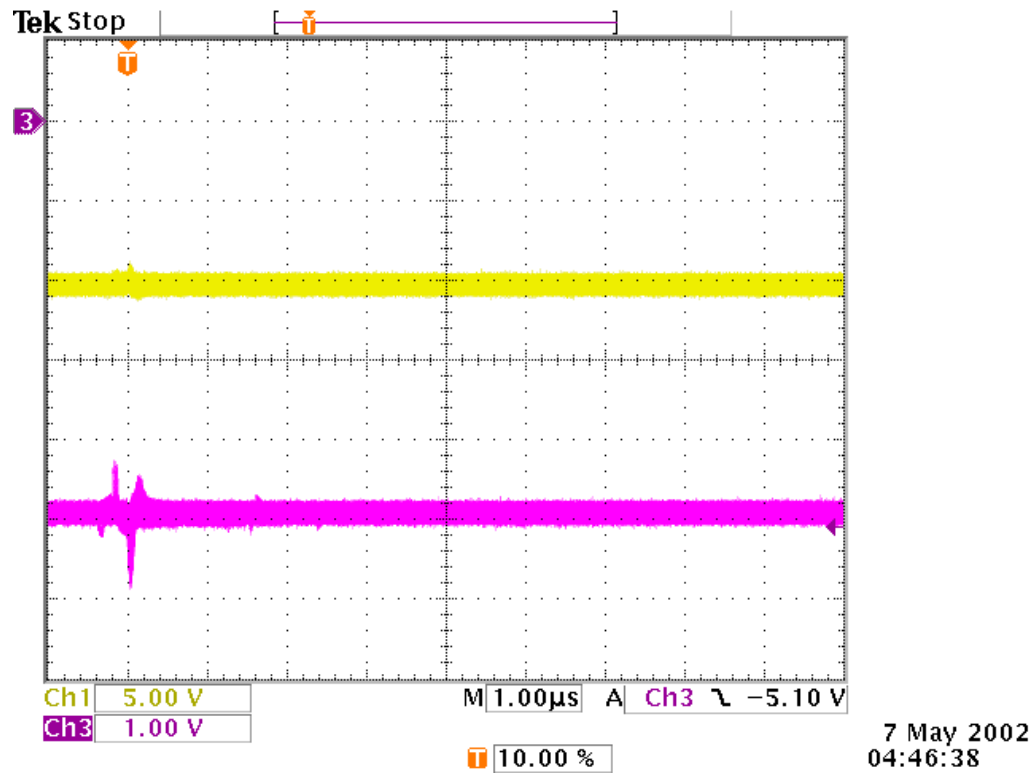

Figure 17: Test #17 Results ($V_{in}=-10V$; $V_{out}=-5V$; $I_{out}=500mA$; $C_{out}=22\mu F$)

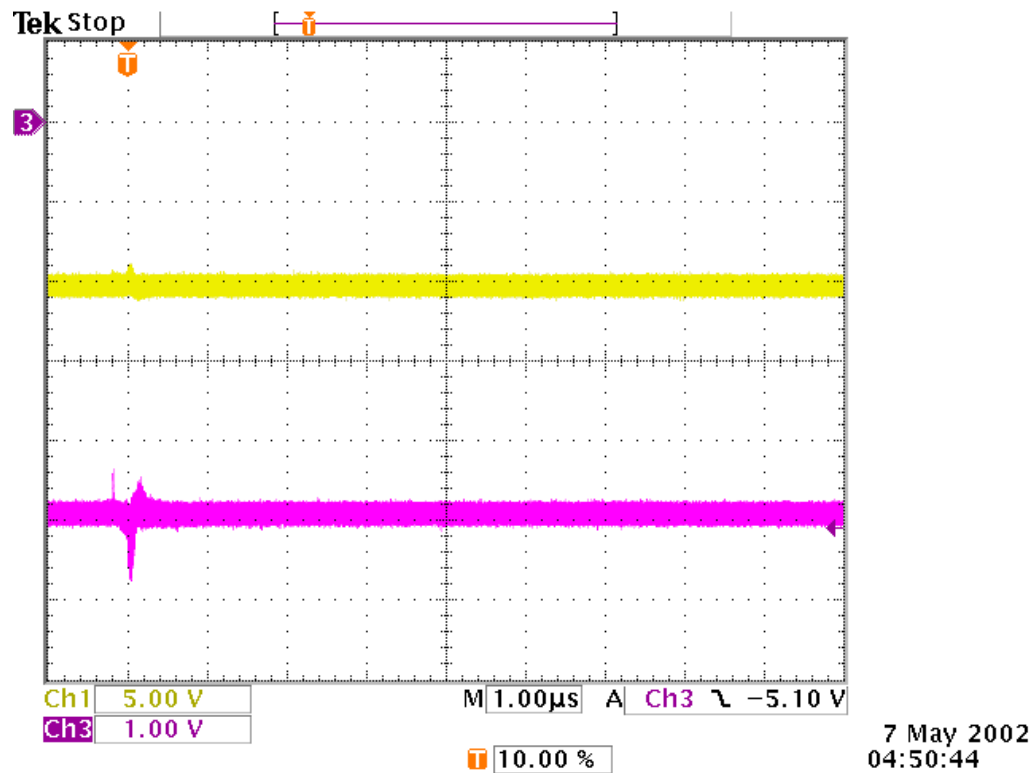

Figure 18: Test #18 Results ($V_{in}=-10V$; $V_{out}=-5V$; $I_{out}=500mA$; $C_{out}=44\mu F$)

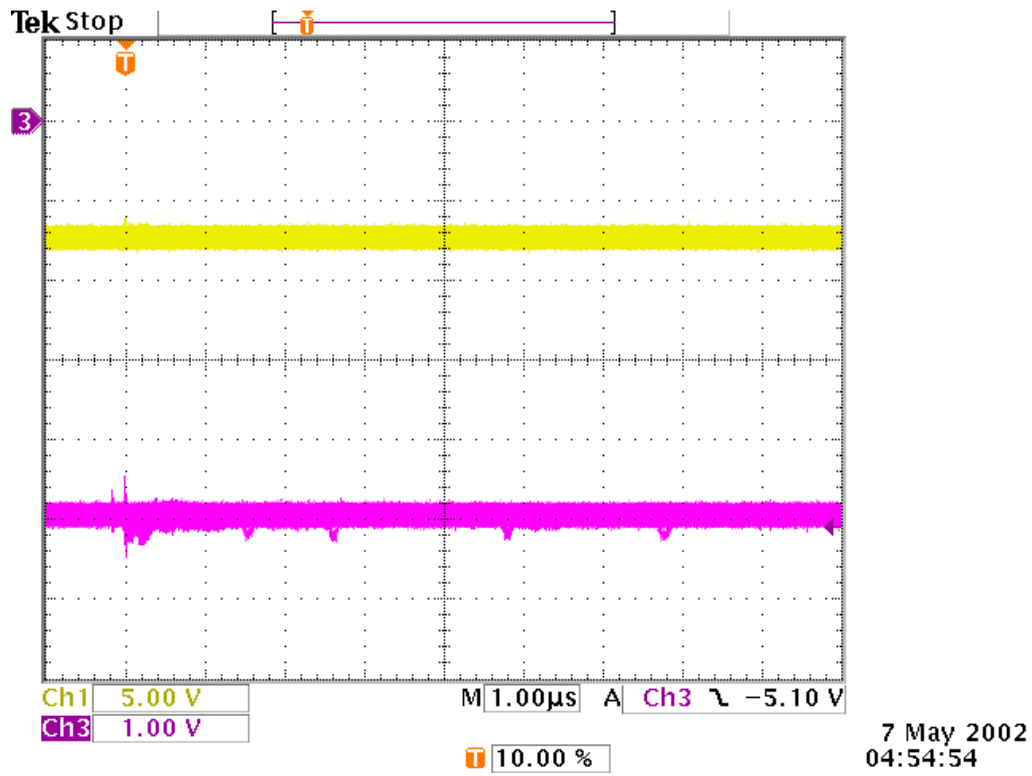

Figure 19: Test #19 Results ($V_{in} = -7V$; $V_{out} = -5V$; $I_{out} = 3.75mA$; $C_{out} = 22\mu F$)

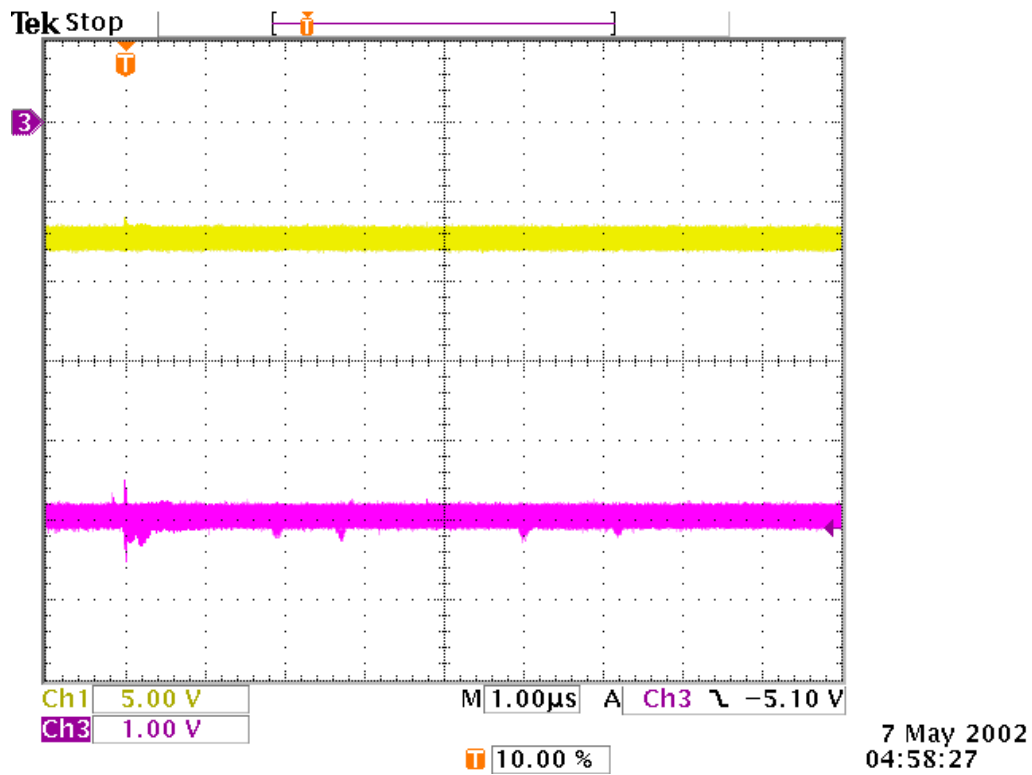

Figure 20: Test #20 Results ($V_{in} = -7V$; $V_{out} = -5V$; $I_{out} = 3.75mA$; $C_{out} = 44\mu F$)

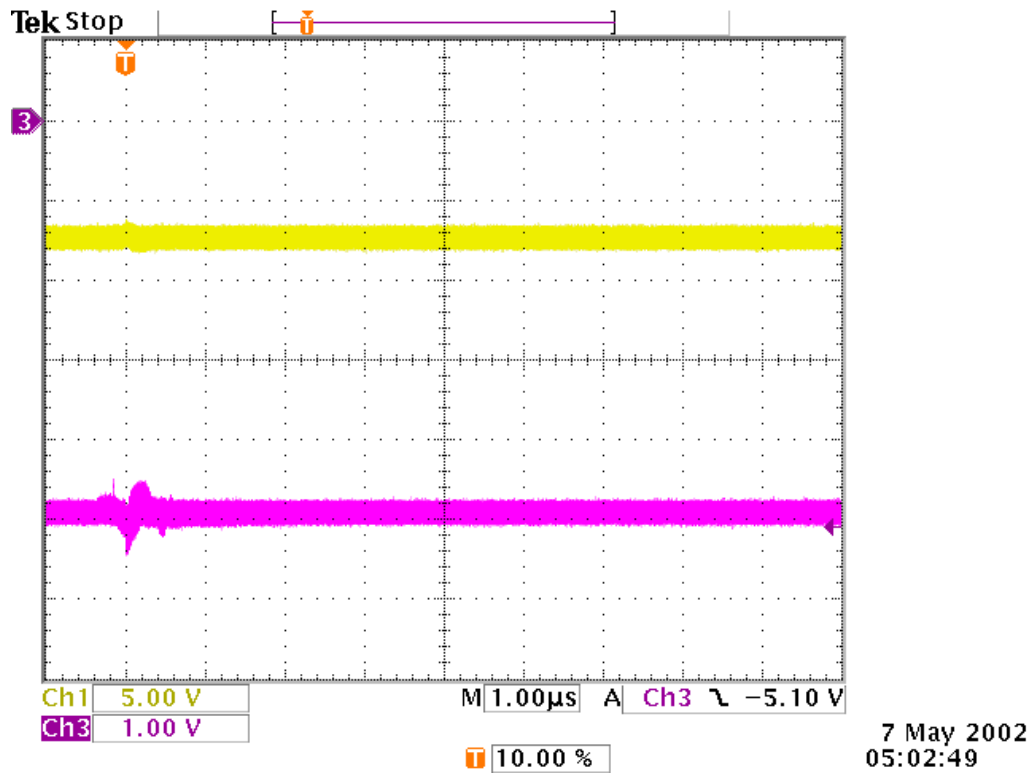

Figure 21: Test #21 Results ($V_{in}=7V$; $V_{out}=-5V$; $I_{out}=500mA$; $C_{out}=22\mu F$)

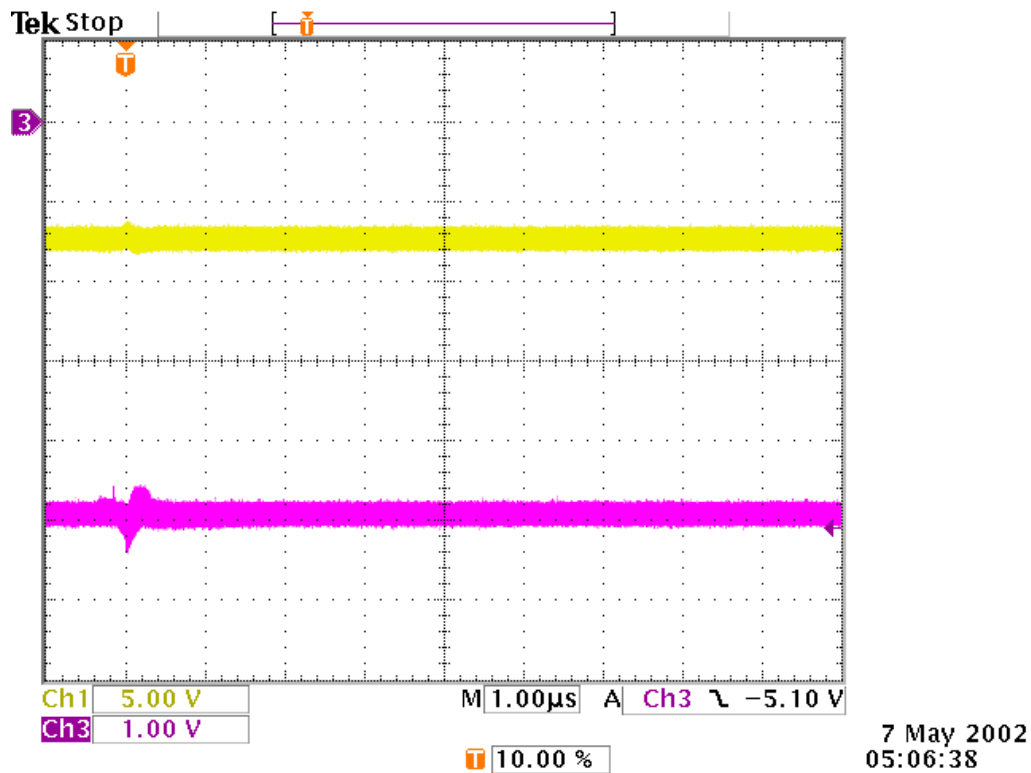

Figure 22: Test #22 Results ($V_{in}=7V$; $V_{out}=-5V$; $I_{out}=500mA$; $C_{out}=44\mu F$)

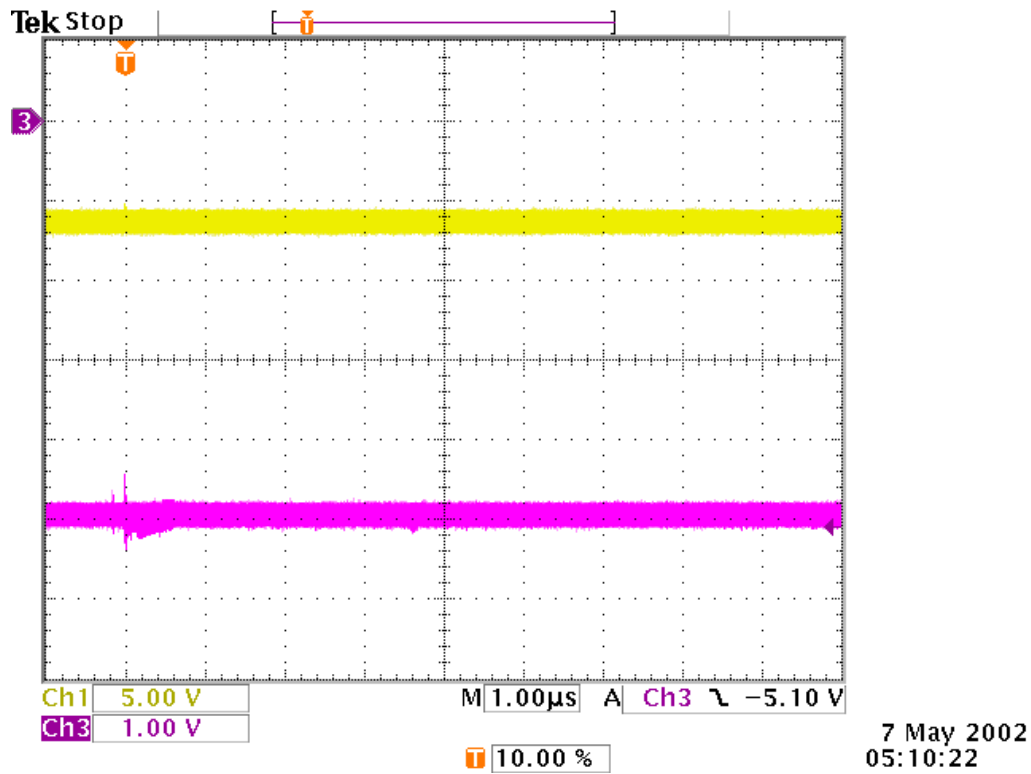

Figure 23: Test #23 Results ($V_{in}=-6V$; $V_{out}=-5V$; $I_{out}=3.75mA$; $C_{out}=22\mu F$)

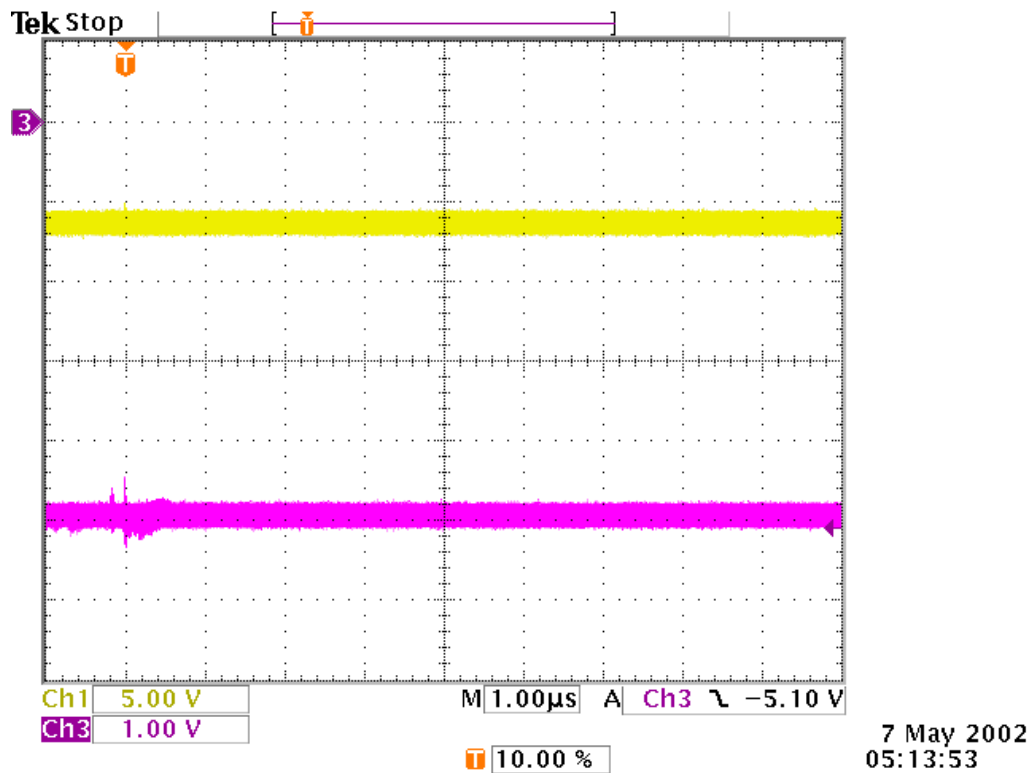

Figure 24: Test #24 Results ($V_{in}=-6V$; $V_{out}=-5V$; $I_{out}=3.75mA$; $C_{out}=44\mu F$)

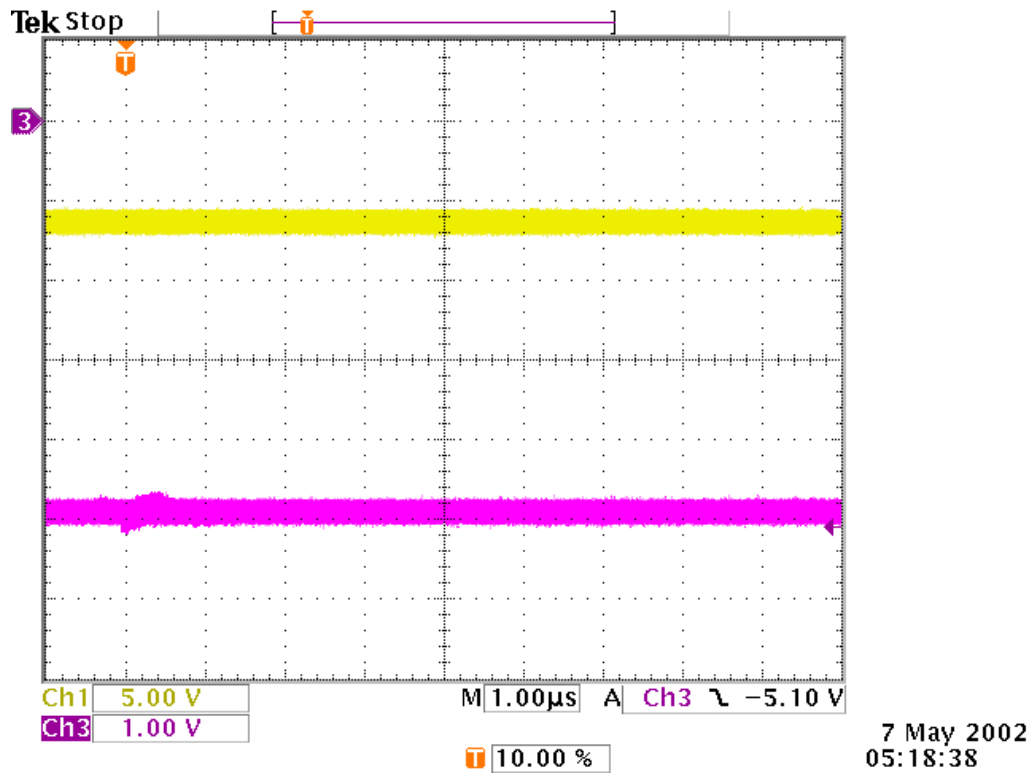

Figure 25: Test #25 Results ($V_{in}=6V$; $V_{out}=-5V$; $I_{out}=500mA$; $C_{out}=22\mu F$)

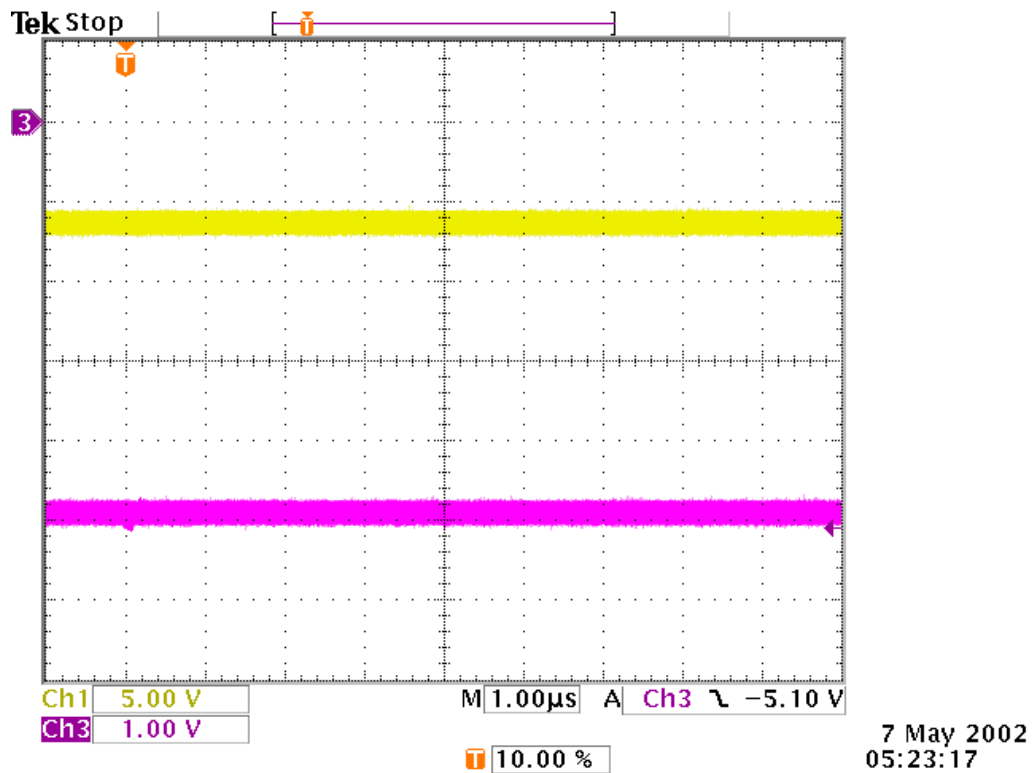

Figure 26: Test #26 Results ($V_{in}=6V$; $V_{out}=-5V$; $I_{out}=500mA$; $C_{out}=44\mu F$)

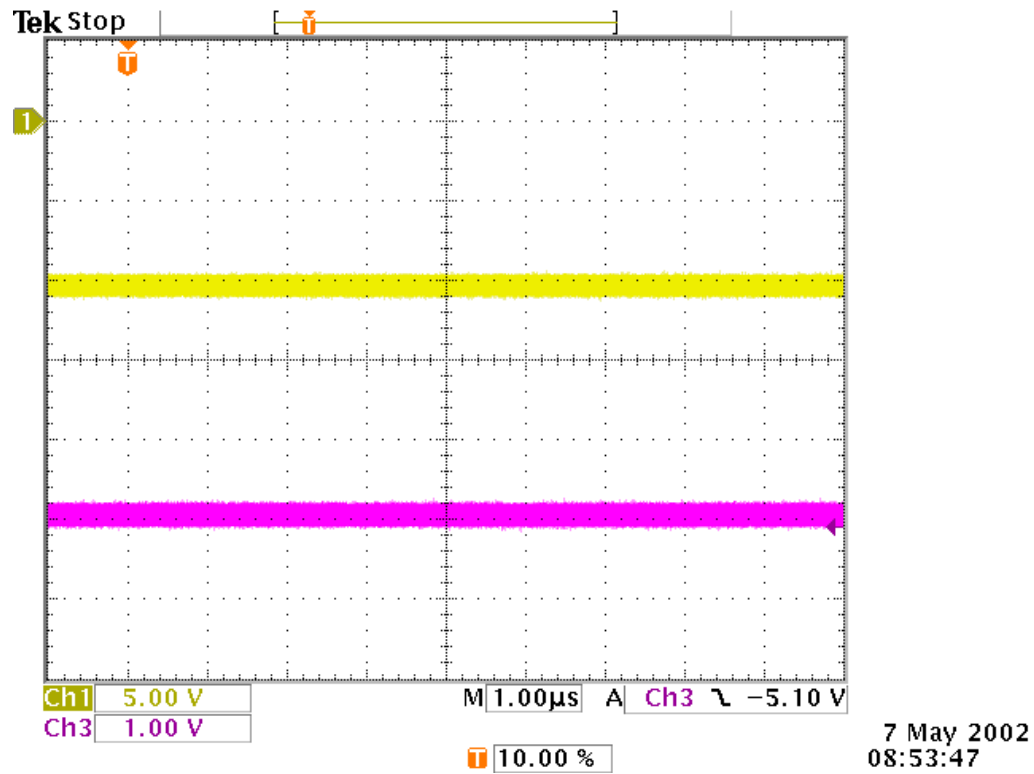

Figure 27: Test #27 Results ($V_{in}=-10V$; $V_{out}=-5V$; $I_{out}=3.75mA$; $C_{out}=22\mu F$)

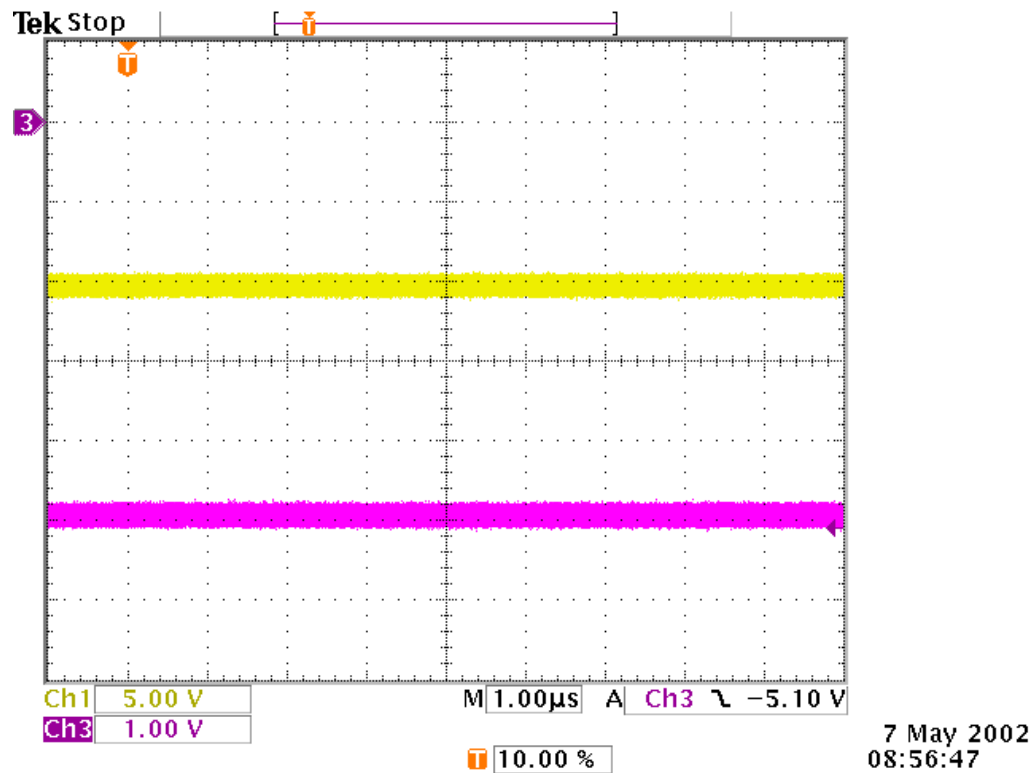

Figure 28: Test #28 Results ($V_{in}=-10V$; $V_{out}=-5V$; $I_{out}=3.75mA$; $C_{out}=44\mu F$)

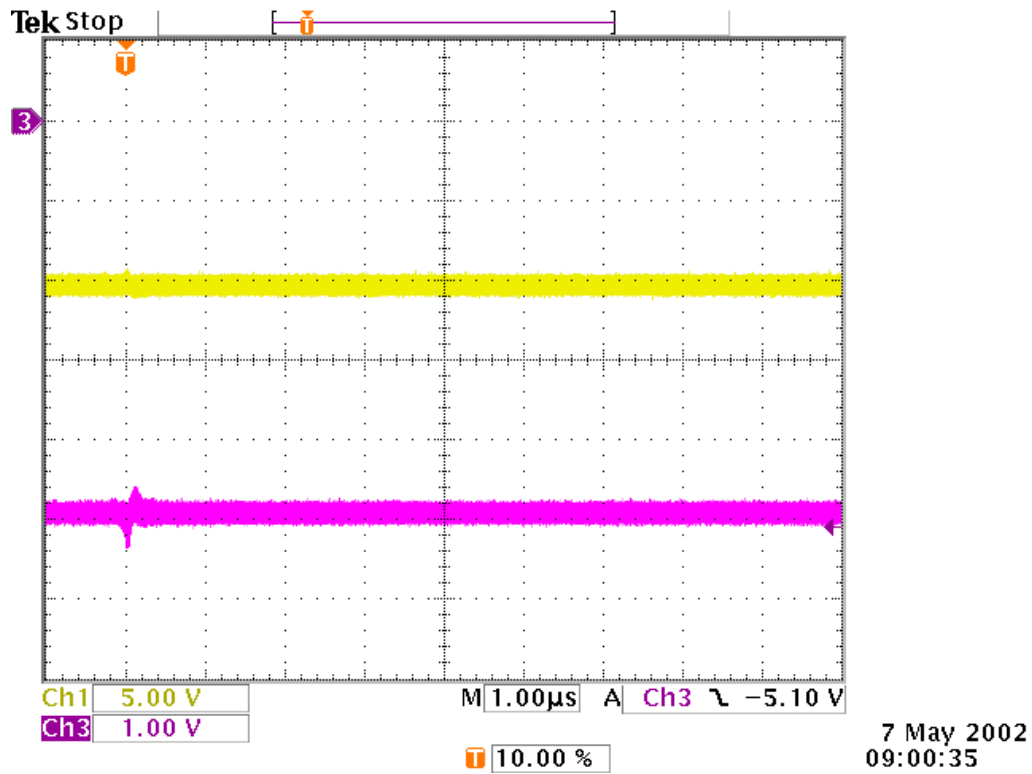

Figure 29: Test #29 Results ($V_{in}=-10V$; $V_{out}=-5V$; $I_{out}=500mA$; $C_{out}=22\mu F$)

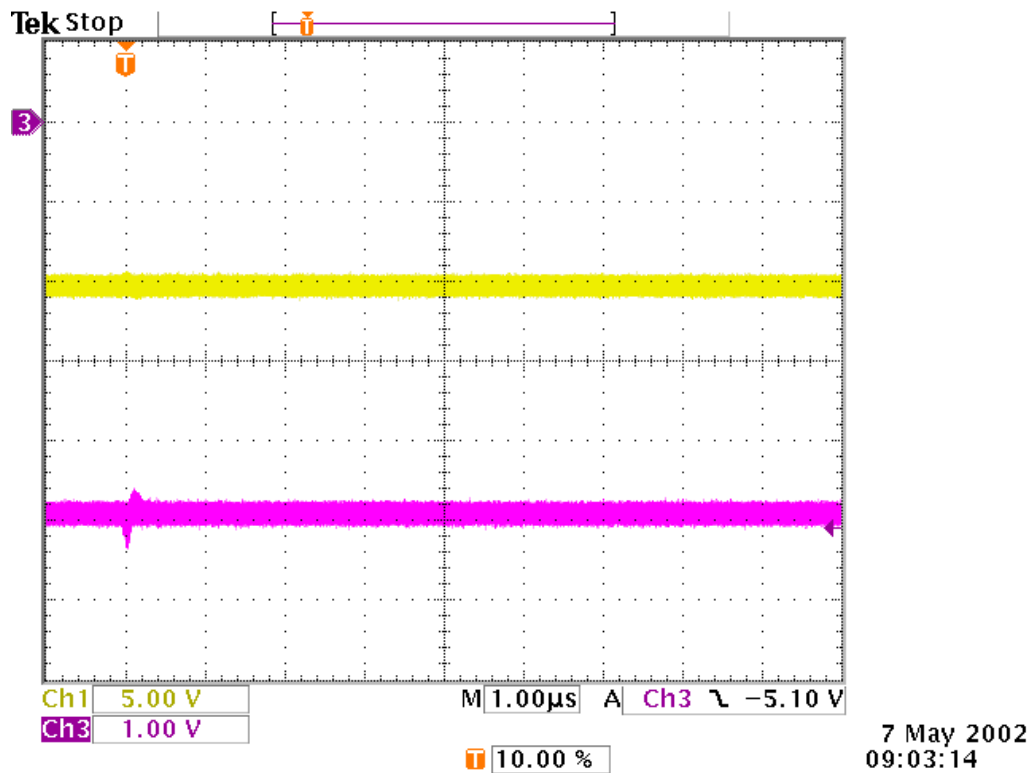

Figure 30: Test #30 Results ($V_{in}=-10V$; $V_{out}=-5V$; $I_{out}=500mA$; $C_{out}=44\mu F$)

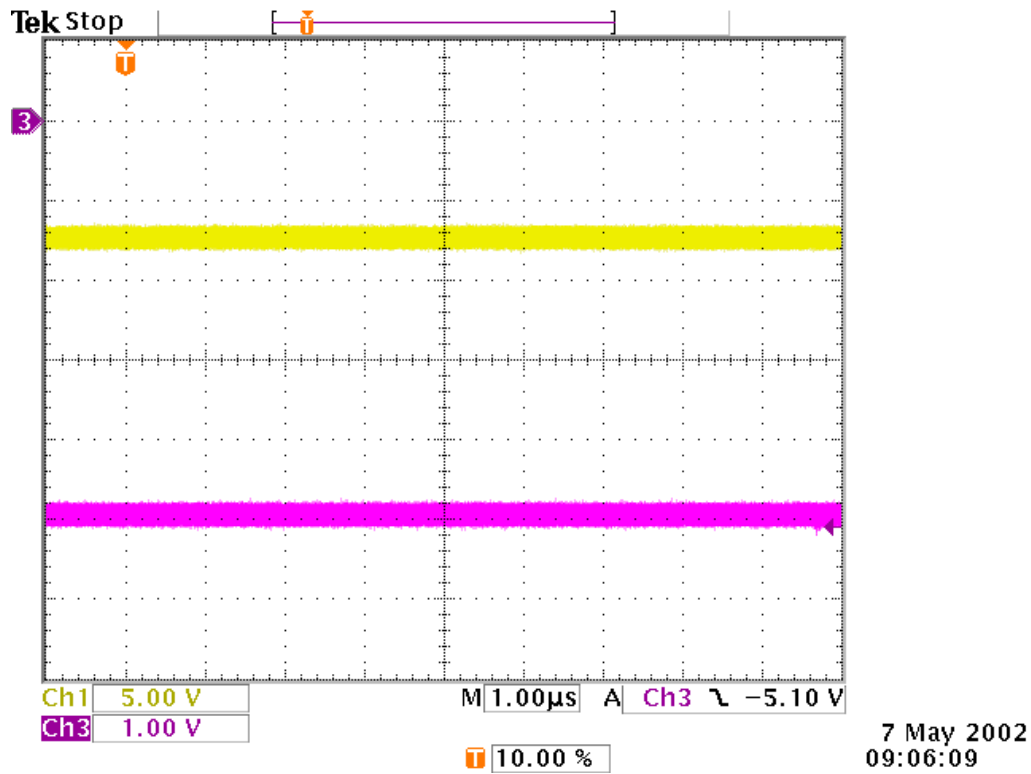

Figure 31: Test #31 Results ($V_{in} = -7V$; $V_{out} = -5V$; $I_{out} = 3.75mA$; $C_{out} = 22\mu F$)

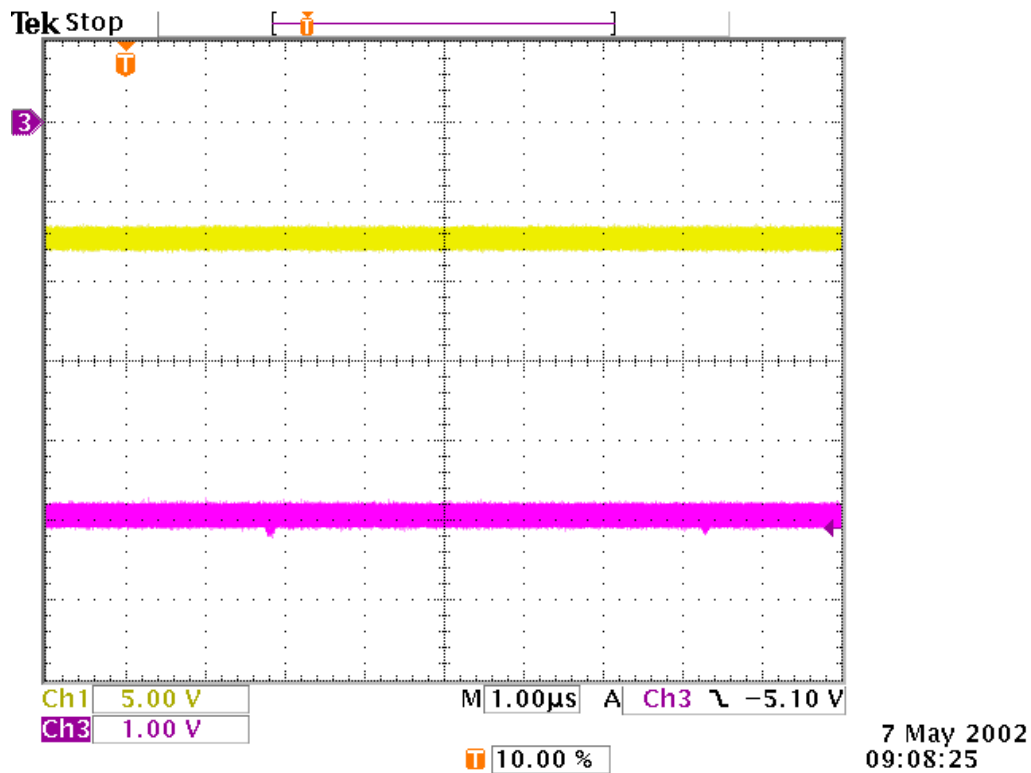

Figure 32: Test #32 Results ($V_{in} = -7V$; $V_{out} = -5V$; $I_{out} = 3.75mA$; $C_{out} = 44\mu F$)

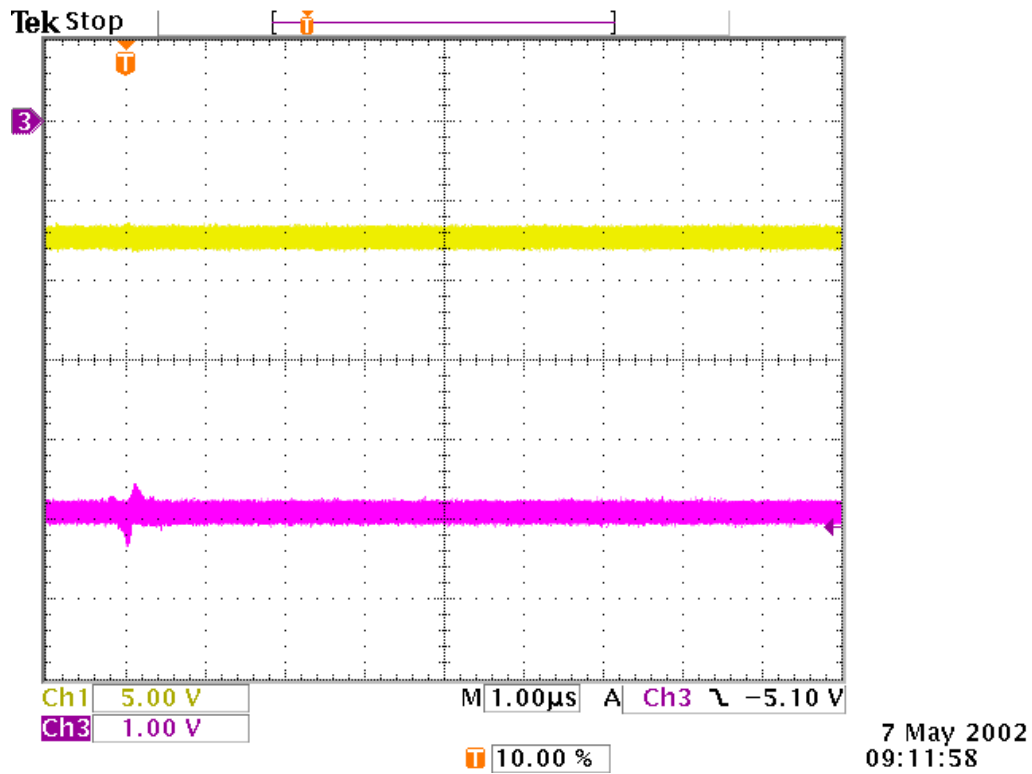

Figure 33: Test #33 Results ($V_{in}=7V$; $V_{out}=-5V$; $I_{out}=500mA$; $C_{out}=22\mu F$)

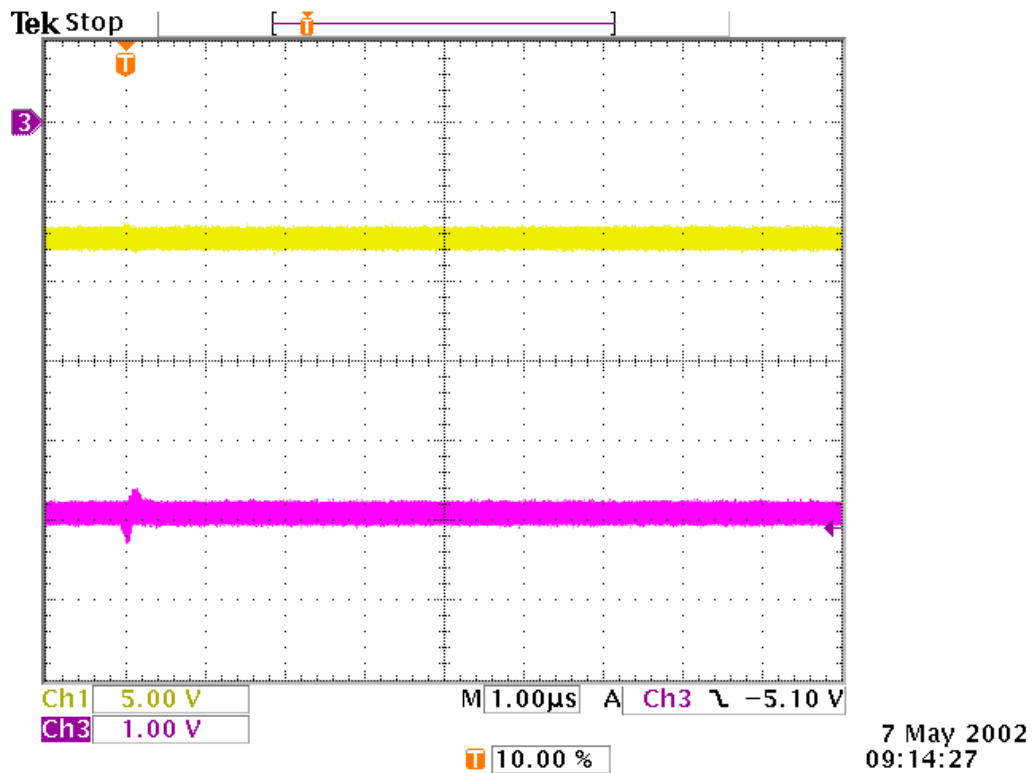

Figure 34: Test #34 Results ($V_{in}=7V$; $V_{out}=-5V$; $I_{out}=500mA$; $C_{out}=44\mu F$)

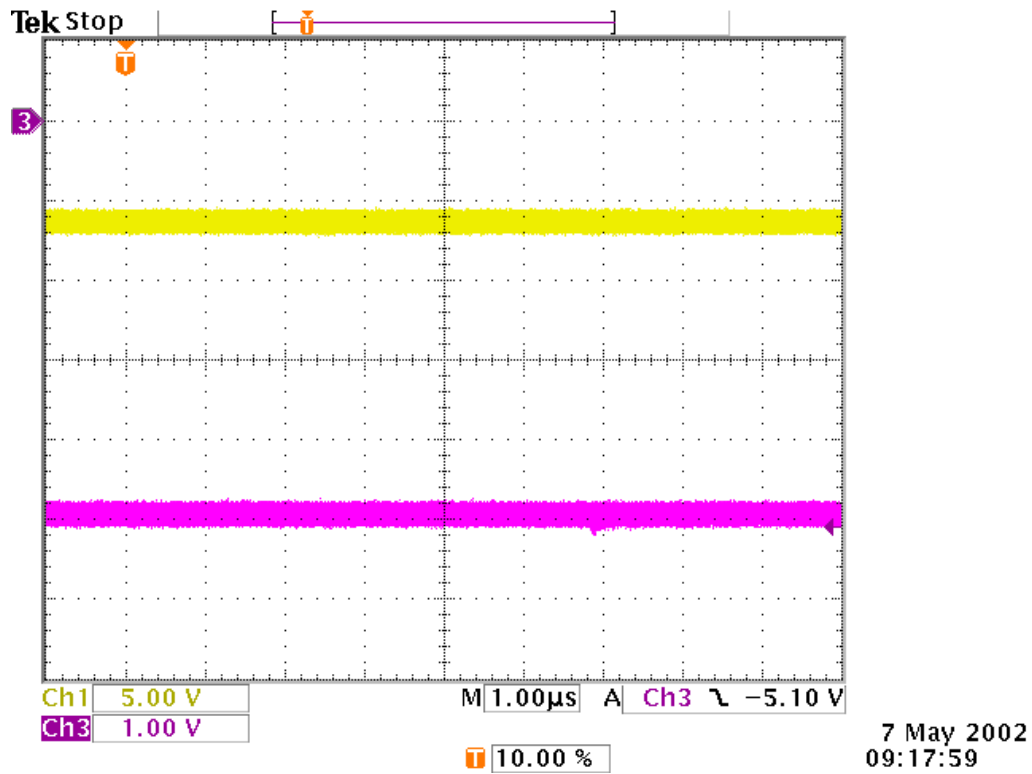

Figure 35: Test #35 Results ($V_{in}=-6V$; $V_{out}=-5V$; $I_{out}=3.75mA$; $C_{out}=22\mu F$)

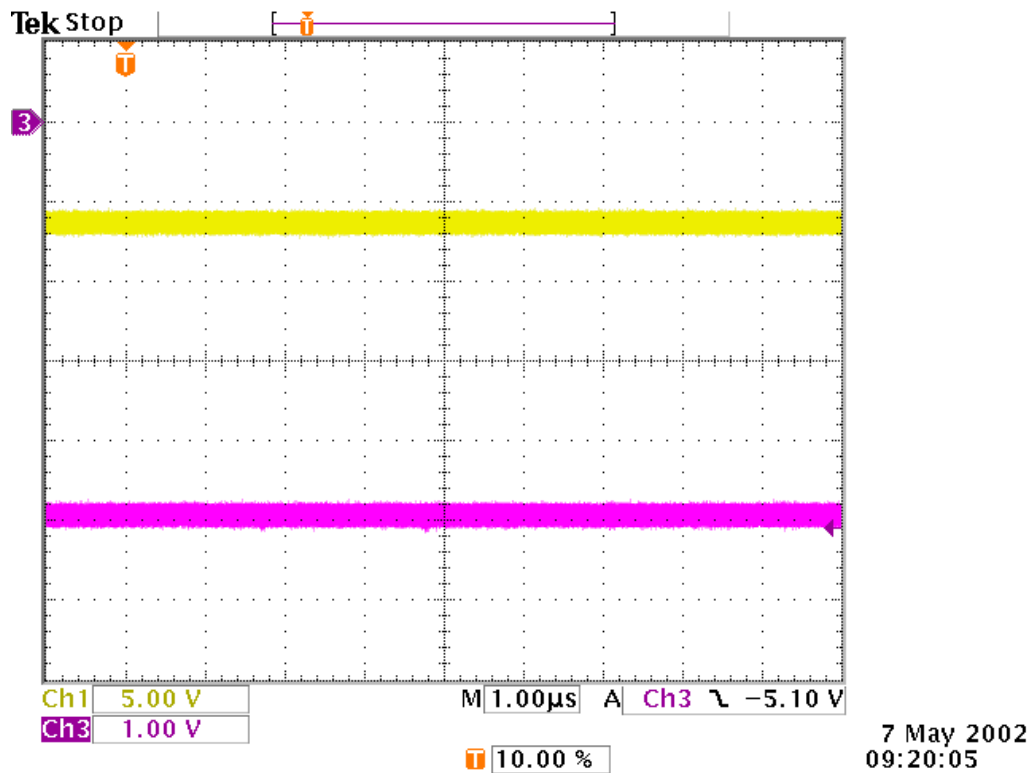

Figure 36: Test #36 Results ($V_{in}=-6V$; $V_{out}=-5V$; $I_{out}=3.75mA$; $C_{out}=44\mu F$)

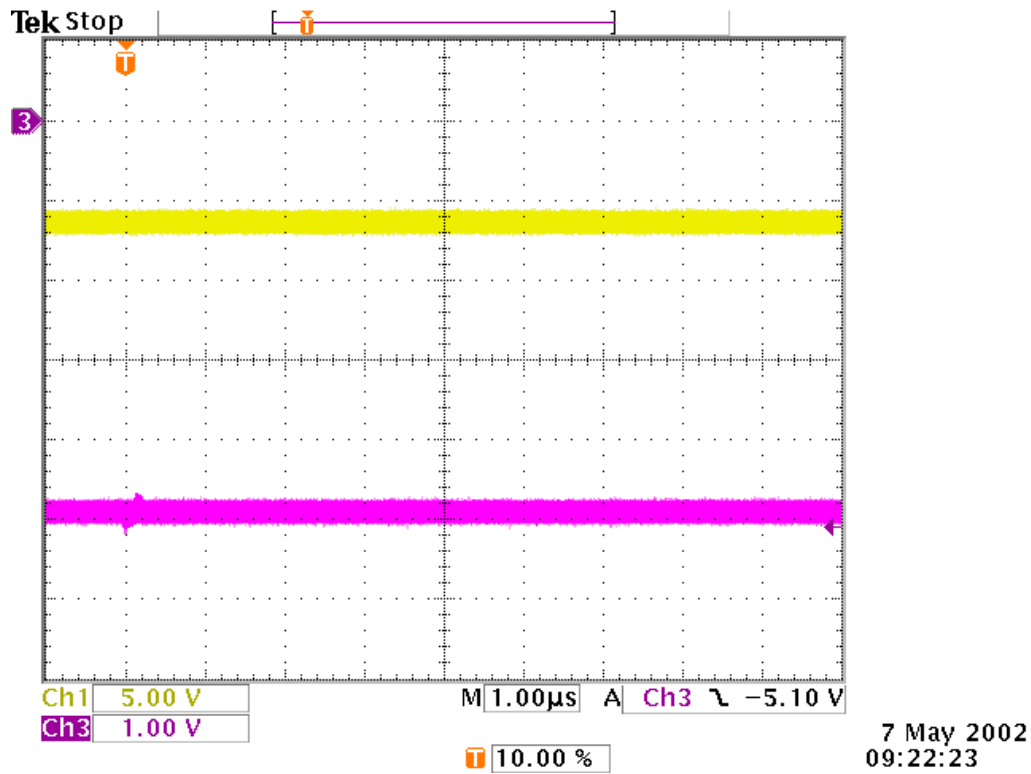

Figure 37: Test #37 Results ($V_{in}=6V$; $V_{out}=-5V$; $I_{out}=500mA$; $C_{out}=22\mu F$)

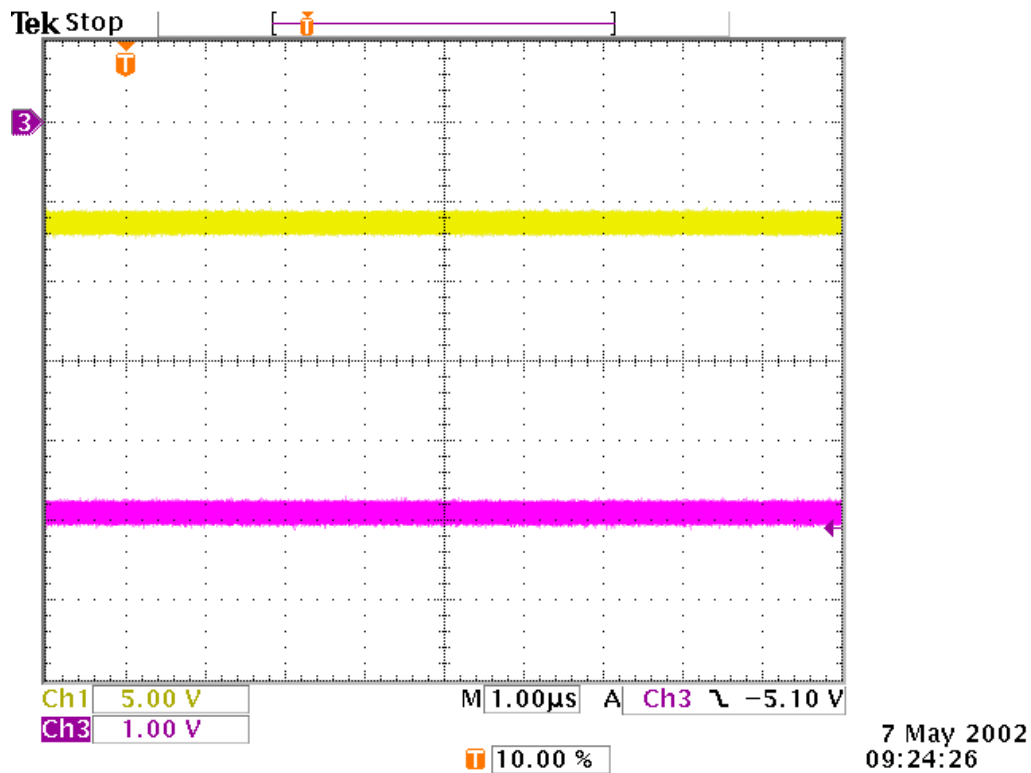

Figure 38: Test #38 Results ($V_{in}=6V$; $V_{out}=-5V$; $I_{out}=500mA$; $C_{out}=44\mu F$)

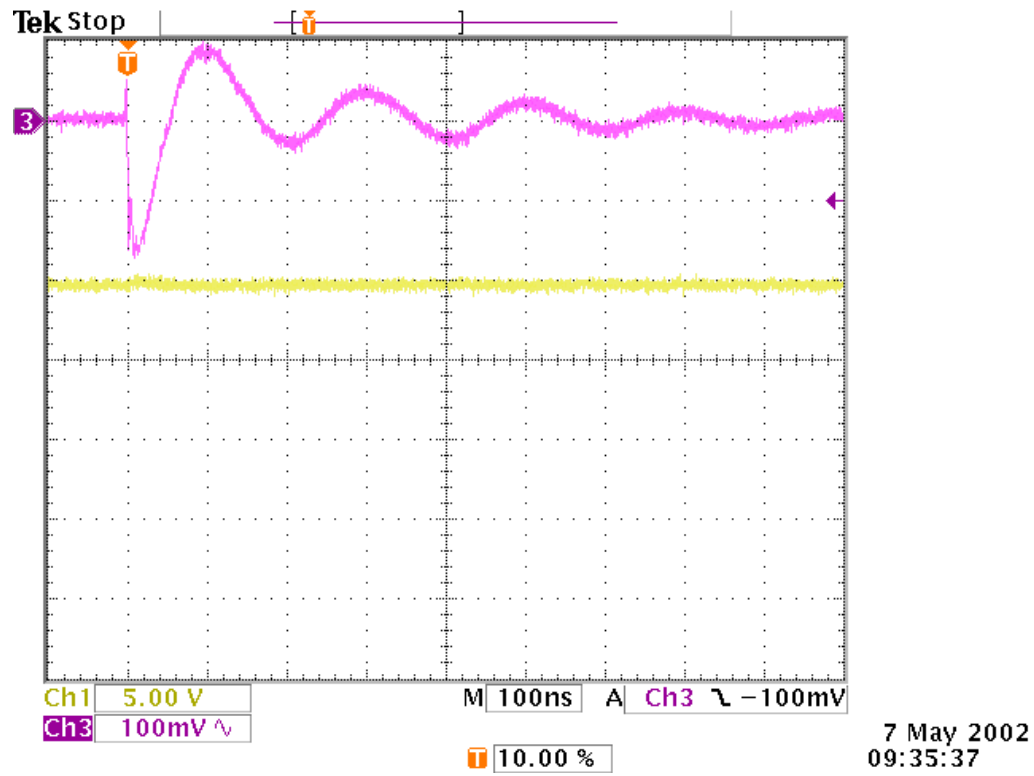

Figure 39: Test #29 Single Sweep Results ($V_{in}=-10V$; $V_{out}=-5V$; $I_{out}=500mA$; $C_{out}=22\mu F$)