

Abstract:

This document provides a brief introduction to low dose rate effects including discussion of Intersil's approach to testing and qualification issues. We then report results of baseline 85krad(Si) low dose rate testing of the Intersil ISL72991RH Negative Low Dropout Voltage Regulator (LDO).

Table of Contents:

- 1: Introduction: What is Low Dose Rate Sensitivity?
- 2: Low Dose Rate Testing Strategy at Intersil
- 3: Low Dose Rate Testing of the Intersil ISL72991RH Negative LDO
- 4: Discussion
- 5: Conclusion
- 6: References

1: Introduction: What is Low Dose Rate Sensitivity?

Low dose rate effects have been a topic of considerable research interest for the last fifteen years. The first section of this report will supply a brief technical introduction to the topic.

Total ionizing dose testing of semiconductor components has historically been performed at 'qualification' dose rates in the 50 – 300rad(Si)/s range as specified in MIL-STD-883. At 50rad(Si)/s, the low end of the dose rate specification range, a lot qualification test to a 300krad(Si) total dose specification takes a maximum of 1.67 hours, enabling the test to be carried out in less than a day. Intersil has historically performed total dose qualification testing of their hardened parts on a wafer by wafer basis, using Gammacell 220™ irradiators; the dose rate of our current Gammacell is approximately 130rad(Si)/s, and the 300krad(Si) test takes 38 minutes.

In the 1992 – 1993 time frame, researchers at Mission Research and Aerospace Corporation noted a surprising dose rate dependence in the total dose response of bipolar analog integrated circuits. Devices such as the industry-standard LM139 comparator showed severe degradation of such parameters as input bias current and input offset voltage when irradiated at very low dose rates. This enhanced low dose rate sensitivity (ELDRS) was subsequently observed in a broad range of bipolar and BiCMOS parts, but has not been seen in MOS parts (except in a very few unconfirmed cases in discrete MOS devices). In MOS parts the effects of low dose rate are opposite to those observed in bipolars; the damage anneals out at a constant rate, so lower dose rate testing causes less degradation, which is a more intuitive result. Figure 1 shows a well-known if somewhat extreme sample response curve [1] for a bipolar operational amplifier.

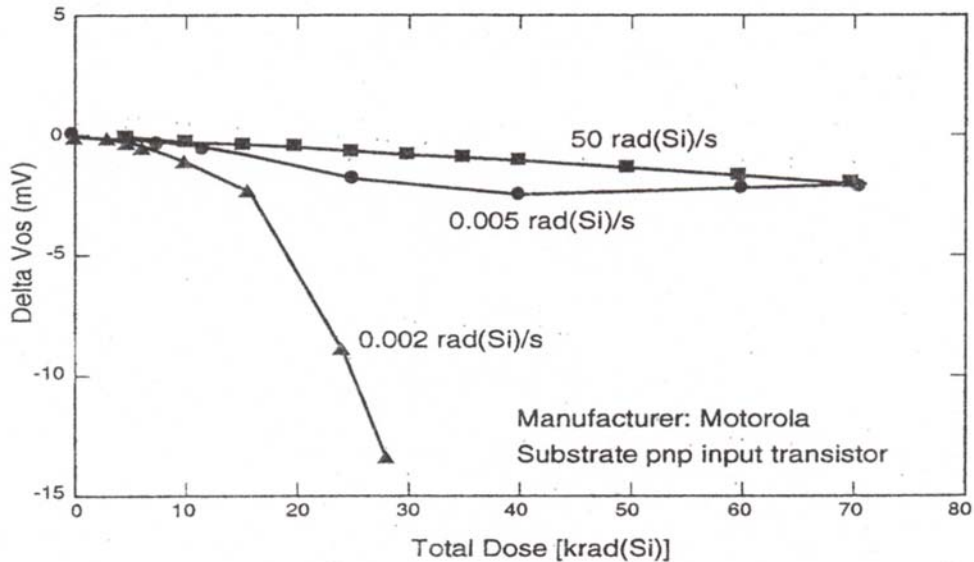

Figure 1: *Where is the bottom?* Degradation of the input offset voltage as a function of total dose of the Motorola LM324 operational amplifier at three dose rates [1]. Note that the input offset voltage shows excellent stability at the 50rad(Si)/s and .005rad(Si)/s dose rates, but degrades rapidly at the very low .002rad(Si)/s dose rate.

Following the initial findings in 1992, low dose rate sensitivity developed into one of the premier research topics in the radiation effects community, as evidenced by a large number of journal papers. Compendia of low dose rate results for a broad range of commercially available parts are particularly useful; these compendia [2] and other papers on the subject can be found in the IEEE Radiation Effects Data Workshop Record, which is published yearly and contains papers presented at the Workshop. The December issue of the IEEE Transactions on Nuclear Science serves as the proceedings of the IEEE Nuclear and Space Radiation Effects Conference (NSREC) and is another excellent source of technical information on low dose rate effects.

There has been significant work on identifying a basic mechanism that explains this effect, with mixed success. The theories relate to trapping and detrapping rates in the IC's dielectric thin film layers. A detailed discussion of the basic mechanisms of ELDRS is outside the scope of this document.

Intersil uses dielectrically isolated (DI) fabrication processes for its hardened analog parts. This eliminates latchup, either electrically or single-event caused, and also enables the use of a vertical PNP bipolar transistor of enhanced performance as compared to lateral devices. Intersil expected these DI parts to show reduced sensitivity to low dose rate due to the vertical PNP structures used. The basis of this claim was the known softness of the lateral or substrate PNP transistors encountered in nearly all commercial junction-isolated (JI) processes. Radiation tests performed for device modeling work had shown the Intersil vertical devices to be much harder than laterals at qualification dose rates in the 50 – 300rad(Si)/s range, and it was expected that the low dose rate response of the vertical PNP device would track its response at high dose rate.

Workers outside and inside Intersil have verified this assumption. In 1999 researchers at NAVSEA/Crane published a paper [3] reporting positive results for the HS9-139RH quad comparator, which was found to be within its post-radiation parametric limits after 300krad(Si) at .01rad(Si)/s. Baseline low dose rate testing of the HS9-139RH quad comparator, HS9S-117RH positive linear voltage regulator and IS1009RH shunt-mode voltage regulator at Intersil is complete [4] and showed similarly positive results. A baseline test on the ISL72991RH low dropout regulator is now complete and the balance of this document reports the results of this test.

2: Low Dose Rate Testing Strategy at Intersil

In Intersil's approach, the standard MIL-STD-883 Method 1019.7 high dose rate wafer by wafer qualification testing is supplemented by baseline low dose rate characterization testing on a part-by-part basis.

To this end Intersil has a J. L. Shepherd and Associates model 484 low dose rate ⁶⁰Co irradiator on line in the Palm Bay, Florida facility. Appropriate fixturing to perform these tests in accordance with the requirements of MIL-STD-883 Method 1019.7 has been constructed and installed. All testing is performed under bias. The fixturing uses the same test boards as the Intersil high dose rate Gammacell 220™ facility; the test configuration and bias voltages are the same as well, insuring a valid comparison between the results of low and high dose rate testing. During irradiation the devices under test are enclosed in a PbAl box, as specified by MIL-STD-883 Method 1019.7. in order to filter out low-energy photons caused by backscattering effects. We use Far West Technology, Inc. (Goleta, CA) model FWT-70 Opti-Chromic radiochromic dosimeters to monitor accumulated dose. Test samples are taken from burned-in production part inventory, as burnin and its attendant heat treats have been shown [5] to play a role in low dose rate response.

3: Low Dose Rate Testing of the Intersil ISL72991RH Negative Low Dropout Regulator

The radiation hardened ISL72991RH is a low dropout adjustable negative regulator with an output voltage range of -2.25V to -26V. The device features a 1A output current capability, an adjustable current limit pin (ILIM) and a shutdown pin (SD) for easy on/off control.

The device incorporates unique circuitry that enables precision performance over the -55°C to +125°C temperature range and post-irradiation. Specifications include a reference voltage of -1.279 to -1.231V, line regulation of ±25mV (maximum), and load regulation of ±12mV (maximum).

A brief summary of features of the ISL72991RH follows.

- Electrically Screened to DSCC SMD 5962-02503
- QML qualified per MIL-PRF-38535 requirements
- Radiation environment:
 - Total dose (maximum) 300krad(Si)
 - Latchup Immune
- Line regulation: ±25mV (maximum)
- Load regulation: ±12mV (typical), ±15mV (maximum)
- Output voltage range: -2.25V to -26V
- Dropout voltage: (100mA): 0.2V (maximum)
- Dropout voltage (1A): 1V (maximum)
- Minimum load current: 3.0mA
- TTL compatible shutdown (SD): Low = On

The part is constructed using the Intersil dielectrically isolated, complementary bipolar RSG process. The process uses silicon dioxide (silox) passivation. It is immune to single-event latchup and has been specifically designed to provide reliable performance in harsh radiation environments. Single-event effects (SEE) characterization testing of the part has been performed and a summary [6] of results can be found on the Intersil homepage.

The Defense Supply Center (DSCC) in Columbus, OH controls Standard Microcircuit Drawings (SMD) for radiation-hardened QML devices. Detailed electrical specifications for these devices are contained in SMD 5962-00523. A "hot-link" is provided on the Intersil homepage for convenient downloading of the SMD, see www.intersil.com/spacedefense/space.htm

A baseline 85krad(Si) low dose rate test of the Intersil ISL72991RH Negative Low Dropout Regulator is complete. This test had intermediate down points of 10krad(Si) and 25krad(Si). Samples were irradiated at a dose rate of 10 millirad(Si)/s, using the J. L. Shepherd and Associates model 484 low dose rate irradiator. The sample size for this test was 13, and the parts were irradiated per MIL-STD-883 Method 1019.7 using the irradiation bias configuration specified in SMD 5962-00523 (see Figure 2, below). This irradiation bias is used to permit a more direct comparison between low and high dose rate results. Note also that the 'all pins grounded' configuration is not always worst case, and internal (unpublished) Intersil data has shown bias sensitivity in some RSG parts. Downpoint testing was performed using the standard automated test equipment (ATE) procedure used for production testing. Samples were drawn from burned-in standard production material, as indicated above, and were packaged in the CDFP3-F28 hermetically sealed 'flatpack' package.

The pre-irradiation, 10krad(Si), 25krad(Si) and 85krad(Si) results are summarized in Figures 3 - 7, below. Included with the low dose rate results are data points and trend lines for equivalent high dose rate data drawn from routine wafer-by-wafer qualification testing. This added data enables a direct comparison between low and high dose rate results.

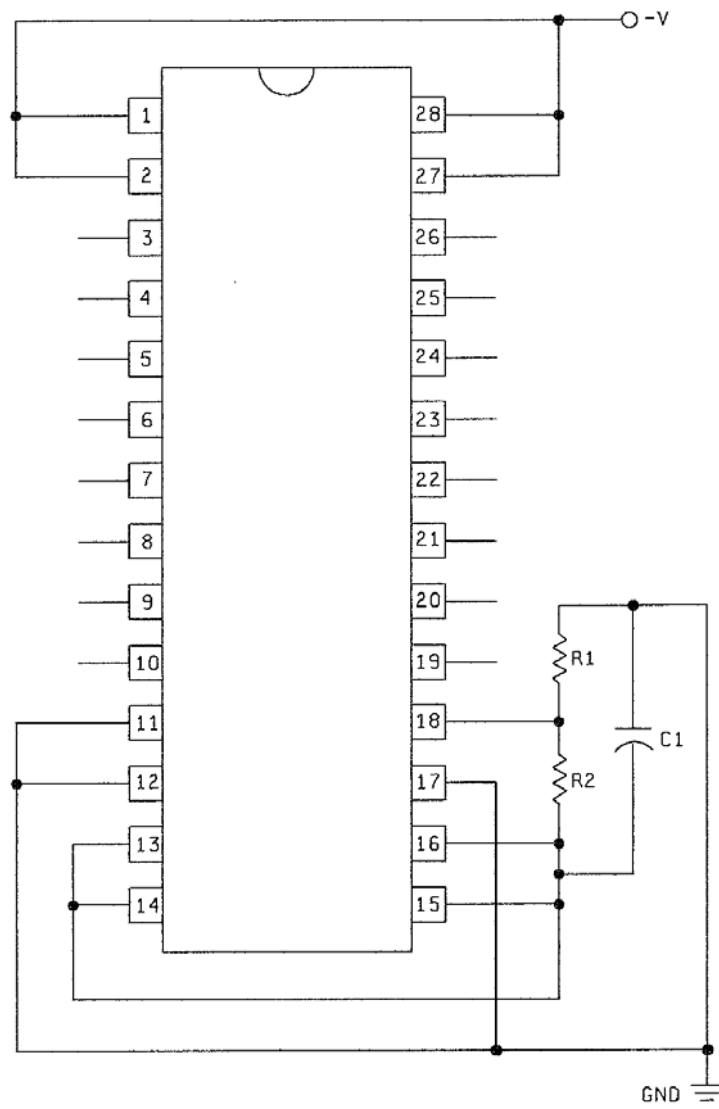

$-V = -25\text{ V} \pm 0.5\text{ V}$, $C1 = 47\ \mu\text{F}$,
 $R1 = 250\ \Omega$, $1/8\text{ W at } 5\%$
 $R2 = 750\ \Omega$, $1/8\text{ W at } 5\%$

Figure 2: ISL72991RH irradiation bias configuration per SMD 5962-00523

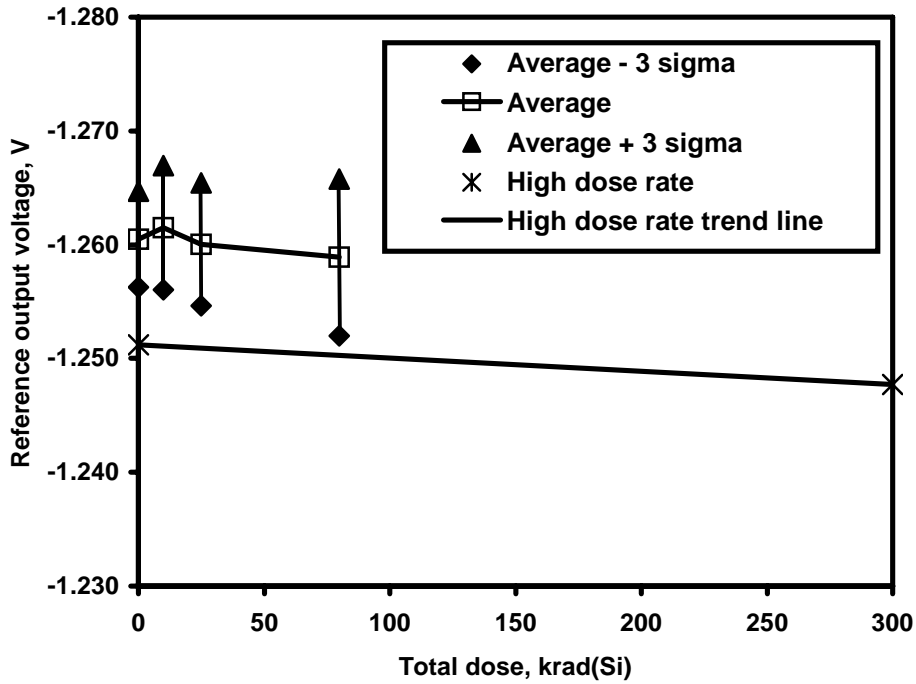

Figure 3: ISL72991RH reference output voltage as a function of total dose, low and high dose rate (.01rad(Si)/s and 120rad(Si)/s). Sample size is 13 parts. The maximum voltage range specification is -1.279 to -1.231 V.

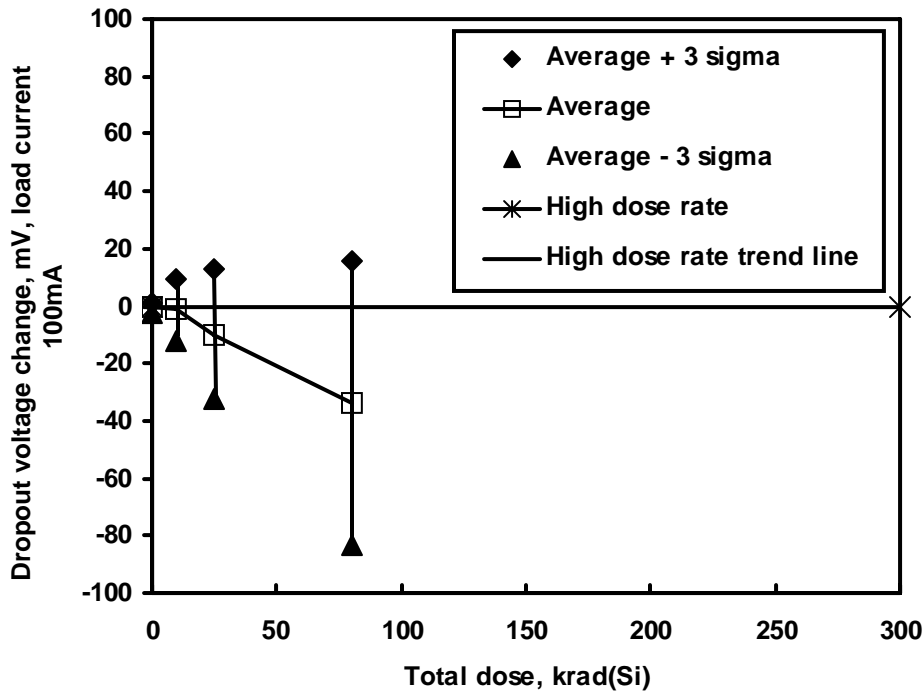

Figure 4: ISL72991RH dropout voltage measurement. The plot shows the output voltage change as a function of total dose, load current 100mA, low and high dose rate (.01rad(Si)/s and 120rad(Si)/s). See Section 4 for further test details. Sample size is 13 parts. The maximum post-radiation output voltage change specification is 50mV.

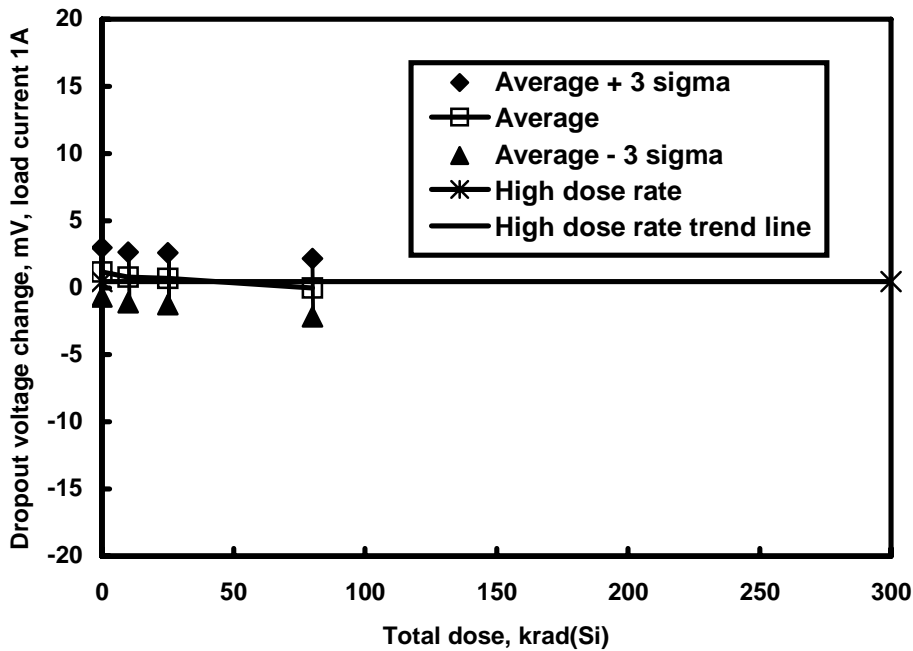

Figure 5: ISL72991RH dropout voltage measurement. The plot shows the output voltage change as a function of total dose, load current 1A, low and high dose rate (.01rad(Si)/s and 120rad(Si)/s). See Section 4 for further test details. Sample size is 13 parts. The maximum post-radiation output voltage change specification is 50mV.

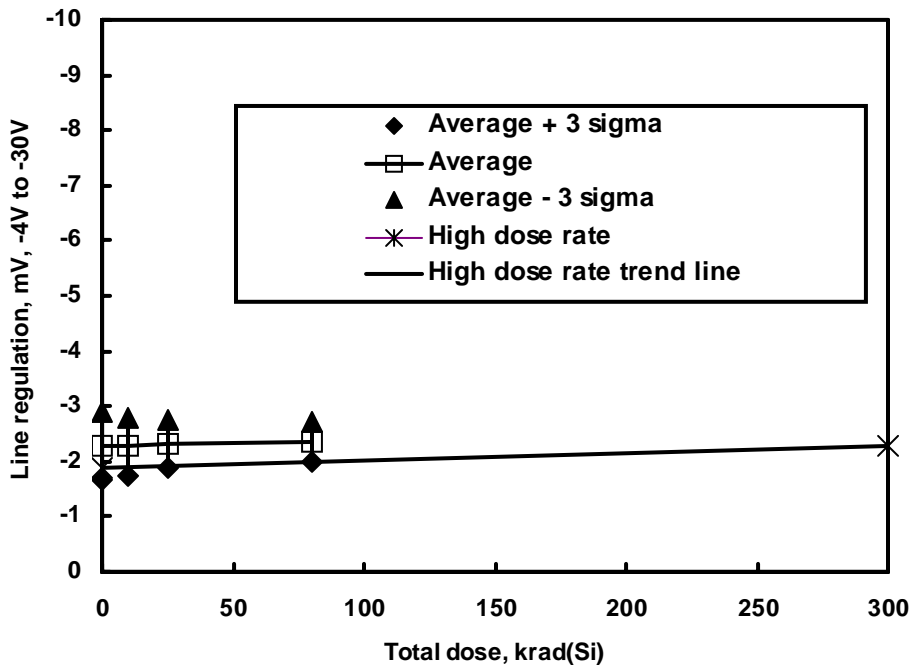

Figure 6: ISL72991RH line regulation as a function of total dose, low and high dose rate (.01rad(Si)/s and 120rad(Si)/s). Plot shows output voltage change for an input voltage change from -4V to -30V. Sample size is 13 parts. The minimum post-radiation output voltage change specification is +/-25mV.

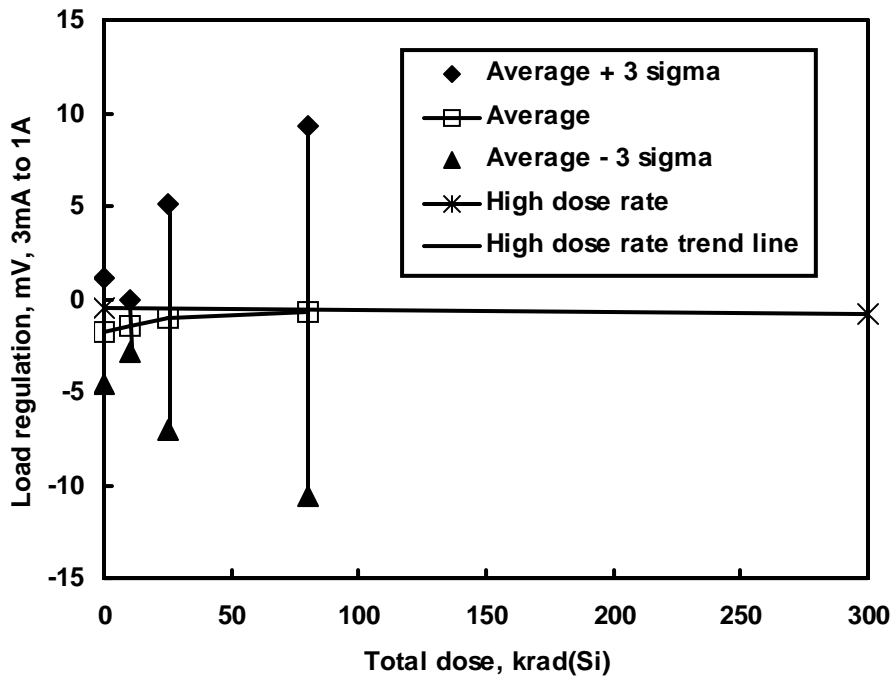

Figure 7: ISL72991RH load regulation as a function of total dose, low and high dose rate (.01rad(Si)/s and 120rad(Si)/s). The plot shows output voltage change for an output current change from 3mA to 1A. Sample size is 13 parts. The minimum post-radiation output voltage change specification is +/-12mV.

4: Discussion

The dropout voltage measurement merits some discussion, as it is an indirect measurement. The test sequence is as follows:

A: With an input voltage of -7.0V, set the regulator output voltage to -5V by connecting a 1.2K resistor from the SET pin to ground. Set the output load current to 100mA and measure the output voltage, which should be close to -5V. Store the output voltage V_{out1} . With a drop across the pass transistor of about 2V, the pass transistor is well out of saturation and the regulator is not in a low dropout voltage state.

B: Now set the regulator input voltage as follows:

$$V_{in} = V_{out1} - 200mV$$

In this configuration the regulator output is still set at -5V, but the input voltage is reduced to within 200mV of that output voltage. This places the regulator in the LDO mode; the pass transistor saturates, and the drop across the pass transistor approaches the offset voltage of the transistor. The 200mV represents the maximum post-radiation dropout voltage specification for 100mA load current.

C: Next, measure the regulator output voltage again. It should be within 50mV of the value V_{out1} measured in Step A. Differences in excess of 50mV indicate that the dropout voltage is in excess of 200mV and that the regulator is starting to drop out of regulation.

D: Repeat the above procedure for a load current of 1A and a maximum dropout voltage value of 1V. Again, the maximum output voltage change is 50mV.

The ISL72991RH is built in the Intersil RSG process, which has been shown to have moderate ELDRS sensitivity. Figures 3 – 7 show low dose rate data for selected parameters. The figures also show data points and trend lines for the results of production high dose rate wafer-by-wafer acceptance testing. These tests are conducted on samples drawn from each production wafer. The samples are irradiated per MIL-STD-883 Method 1019.7 test condition A, under bias and with a dose rate of 120rad(Si)/s using a Gammacell 220 60Co irradiator. For the high dose rate data we do not show standard deviation bounds, as the data represents several lots and the populations are different. The data shows pre-irradiation and post 300krad(Si) average values, as these are qualification tests and no intermediate downpoints are used.

The internal voltage reference showed excellent stability [Figure 3] for both the high and low dose rate cases. The average absolute values between the two dose rates are different, which is to be expected given this is a trimmed part and the data represents several lots. The dropout change (see above for a detailed description of this test) at 100mA load current [Figure 4] shows dose rate sensitivity, possibly due to low current gain degradation of the NPN pass device. The same parameter at 1A load current [Figure 5] on the other hand shows no dose rate sensitivity. The line regulation [Figure 6] also shows no dose rate sensitivity, but the load regulation [Figure 7] does, again indicating low current gain degradation in the low dose environment.

We conclude that the ISL72991RH shows only moderate dose rate sensitivity up to a level of 100krad(Si).

5: Conclusion

This document provides technical background, test conditions, data and conclusions of a low dose rate test of the ISL72991RH performed at Intersil Corporation. The ISL72991RH showed only moderate dose rate sensitivity after 100krad(Si) low dose rate irradiation.

6: References

- [1] A.H. Johnston, C.I. Lee and B. G. Rax, 'Enhanced Damage in Bipolar Devices at Low Dose Rates: Effects at Very Low Dose Rates', *IEEE Transactions on Nuclear Science*, December 2002.
- [2] R. L. Pease, S. S. McClure, A. H. Johnston, J. Gorelick, T. L. Turflinger, M. Gehlhausen, J. Krieg, T. Carriere and M. R. Shaneyfelt, 'An Updated Data Compendium of Enhanced Low Dose Sensitive (ELDRS) Bipolar Linear Circuits', *IEEE 2001 Radiation Effects Data Workshop Record*, July 2001.
- [3] J. F. Krieg, J. L. Titus, D. Emily, M. Gehlhausen, J. W. Swonger and D. C. Platteter, 'Enhanced Low Dose Rate Sensitivity (ELDRS) in a Voltage Comparator which only Utilizes Complementary Vertical NPN and PNP Transistors', *IEEE Transactions on Nuclear Science*, December 1999.
- [4] http://www.intersil.com/military/ELDRS_Test_Report.asp
- [5] M. R. Shaneyfelt et al., 'Elimination of Enhanced Low-Dose-Rate Sensitivity and Thermal Stress Effects in Linear Bipolar Devices', *IEEE Transactions on Nuclear Science*, December 2002.
- [6] http://www.intersil.com/military/SEE_Test_Report.asp

Document generated January 2007
Nick van Vonno
Intersil Corporation