

## Introduction

The ISL1208 Real Time Clock (RTC) device shares much of the functionality of the M41T00 device plus some added features, and in some instances may be desirable as a replacement for that device. This Tech Brief will describe the differences between the devices and give guidelines on any changes in hardware or software that are required to drop the ISL1208 into the M41T00 socket. This document should be used as a guideline. Any final design changes should be made after consulting the details in the appropriate data sheets.

## Hardware Compatibility

### Packaging

The SOIC packages for the two devices contain identical pinouts. There are functional differences between the devices for pin 3 ( $V_{BAT}$ ) and pin 7(SQW/OUT). A discussion of these two pins and functions follows.

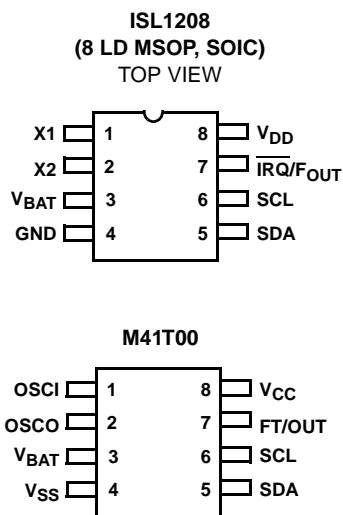

FIGURE 1. PACKAGE PINOUTS

### FT/OUT Pin

Pin 7 of the M41T00 is dedicated to the clock output function, fixed at a frequency of 512Hz. Pin 7 of the ISL1208 combines the clock output with an interrupt output function. This pin is open drain in both products, so a pull-up is required. The ISL1208 has an alarm interrupt and the M41T00 has no alarm function. The hardware interrupt in the ISL1208 is generated upon occurrence of an alarm if the clock output function is not used. If the designer chooses to use the ISL1208 in the M41T00 socket, the alarm function (see ISL1208 data sheet) may be added.

Register 07h of the M41T00 uses the two LSB's to enable the FT/OUT frequency output (see Table 1). Register 08h of

the ISL1208 uses the 4 LSB's to control the Fout frequency (15 frequencies plus disable), so a software change will be needed for this function. The duty cycle is fixed for both devices at 50%. The M41T00 also allows setting pin 7 high or low when not used, using Bit 7 of Register 07h for control. The ISL1208 defaults this pin to high when not used.

### $V_{BAT}$ Pin

The two devices share the same pin for the battery input, pin 3. The ISL1208 has a wider range for  $V_{BAT}$ , however, from 1.8V to 5.5V (vs 2.0V to 3.5V for the M41T00). Also, battery switchover is normally at 2.2V (typ) for the ISL1208 (vs  $V_{BAT} - 0.5V$  for the M41T00). A separate mode can be programmed for the ISL1208 so that it switches over at  $V_{DD} = V_{BAT}$  (similar to the M41T00), if the designer requires that functionality (see ISL1208 data sheet).

### BATTERY BACKUP

Both the M41T00 and the ISL1208 are volatile devices and will lose their register contents when fully powered down ( $V_{BAT}, V_{DD} = 0V$ ).

### Crystal and Oscillator Requirements

Both devices require a standard 32.768kHz crystal, with similar crystal specifications. Both devices allow an external CMOS level clock to override the crystal oscillator by applying to the X1 pin. Note that the ISL1208 requires a control bit to be set (XTOSCB, Register 07h, bit 5), in order to use an external clock.

The ISL1208 provides two methods of adjusting the clock frequency: an analog trimming register(ATR) and a digital trimming register(DTR). The M41T00 has just a digital trimming function, which is controlled by Register 07h. If factory calibration of the oscillator frequency is desired, the ATR function of the ISL1208 is faster and more efficient.

### Register Compatibility

The registers for the two devices are set up somewhat differently. See Table 1. Registers 00h to 02h, the RTC timekeeping registers for the Seconds, Minutes, and Hours, in that order, are essentially the same. There is a difference in Register 00h whereby MSB is used to stop the oscillator. That function is done in the ISL1208 by the XTOSCB bit in register 07h. Also, register 02h for the M41T00 has two MSBs that control century counting; these are absent from the ISL1208. The RTC Date, Day of Week, and Year registers are identical bit setup, but different addresses (this is noted by the color shading of those registers in Table 1). Software will definitely need to be changed to write to and read from the RTC time registers in the ISL1208.

## Technical Brief 464

**TABLE 1. REGISTER DESCRIPTIONS**

ADDR	M41T00	ISL1208	COMMENTS
	RTC REGISTERS		
00h	RTC Seconds, BCD	RTC Seconds, BCD	M41T00 has a Stop bit (ST) in the MSB; otherwise BCD Seconds are the same.
01h	RTC Minutes, BCD	RTC Minutes, BCD	Identical contents.
02h	RTC Hours, BCD	RTC Hours, BCD	The two MSB's in the M41T00 are for Century bit control (years); otherwise BCD Hours are the same.
03h	RTC Day of Week, BCD	RTC Date, BCD	M41T00 Register 03h is identical to ISL1208 Register 06h.
04h	RTC Date, BCD	RTC Month, BCD	M41T00 Register 04h is identical to ISL1208 Register 03h.
05h	RTC Month, BCD	RTC Year, BCD	M41T00 Register 05h is identical to ISL1208 Register 04h.
06h	RTC Year, BCD	RTC Day of Week, BCD	M41T00 Register 06h is identical to ISL1208 Register 05h.
CONTROL/STATUS			
07h	Status Register	Status Register	M41T00 Status Register is used for frequency control calibration (6 bits), similar to the ATR/DTR function in the ISL1208.
Oscillator Enable	ST bit, Register 00h, bit 7	XTOSCB, Register 07h, bit 5	Oscillator shutdown or external oscillator. When set to "0", the device operates normally from the crystal oscillator. When set to "1", the oscillator is shut down. For the ISL1208, an external oscillator can be connected to X1.
FUNCTION	ISL1208 UNIQUE FUNCTIONS		
12 to 13h		User Ram	No User RAM on the M41T00.
Write RTC Register		WRTC, Register 07h, bit 4	Needs to be set to "1" in order to write to the RTC registers.
ATR Control		ATR, Register 0Ah	Provides Analog control of the oscillator; pulls the frequency with internal capacitor adjustment.
Frequency Output		FO3:0, Register 08h	Enables external clock output and selects frequency.
LPMODE		LPMODE, Register 08h, bit 5	Low power mode select. A "0" selects battery switchover at $V_{TRIP} = 2.2V$ . A "1" selects battery switchover at $V_{BAT} > V_{DD}$ .
Alarm		Registers 0Ch to 11h contain alarm setting	If no Frequency output is used, the alarm interrupt is output at IRQ/FO <sub>UT</sub> .
DEVICE OPERATION			
V <sub>BAT</sub>	2.0V to 3.5V	V <sub>BAT</sub> from 1.8V to 5.5V	Battery switchover at V <sub>BAT</sub> for the M41T00 vs V <sub>CC</sub> = 2.2V for the ISL1208 (default mode). For V <sub>CC</sub> = 3.3V, the M41T00 with Lithium battery may need dropping diode.
V <sub>CC</sub>	V <sub>CC</sub> from 2.0 to 5.5V	V <sub>CC</sub> from 2.7V to 5.5V	ISL1208 has wider V <sub>IN</sub> range.
Pinout	Same	Same	M41T00 Pin 7 is FT/OUT; no Alarm function.

### Status Register

The M41T00 has no status register but the ISL1208 does. The ISL1208 status register (addr 07h) includes a clock fail bit and one alarm bit (only one alarm in the ISL1208). The clock fail bit denotes the total loss of power to the device and therefore, the RTC registers are no longer valid. The status register for the ISL1208 also provides control bits as well as other status bits, including battery backup indication, write protection, oscillator on/off control and automatic reset of status bits after a read.

### Control Register

The ISL1208, register 08h, is the control register. It contains clock output, battery switchover and alarm control bits (see ISL1208 data sheet). Note that these functions are not available in the M41T00, and if this register is set to 00h (default), that the device will function similar to the M41T00.

### I<sup>2</sup>C Interface: Communicating with the ISL1208 vs the M41T00

There are two major differences between the M41T00 and the ISL1208 when using the I<sup>2</sup>C bus:

1. The first 7 bits of the slave address for the ISL1208 are 1101111, and for the M41T00 are 1101000. Therefore, a software change would need to be made to change the last 3 bits of the slave address.
2. The ISL1208 requires that the WRTC bit (addr 07h, bit 4) be set before writing to the RTC clock registers. This is to protect them from inadvertent writes. This will require a software change as well, since two I<sup>2</sup>C writes will be required for changing the RTC registers.

The proper order for writing to the ISL1208 RTC registers is:

1. Write to addr 07h data 08h (set WRTC bit).
2. Write RTC time to any or all addr 00h through 06h.

Note that the ISL1208 follows the I<sup>2</sup>C spec as closely as possible, and should interface well with microcontrollers that use hardware I<sup>2</sup>C communications.

### Other RTC Devices

The ISL1209 device provides the same functionality as the ISL1208, but includes an event detector function in the 10-lead MSOP package, so a board change is needed for that device. The event detector takes a logic "event" input and uses it to either stop the RTC counter to store the event time, or trigger an interrupt to a microcontroller.

### References

ISL1208 data sheet, Intersil Corporation, [www.intersil.com](http://www.intersil.com)

M41T00 data sheet, ST Microelectronics, [www.st.com](http://www.st.com)