

Using The EL5306 Demo Board



The EL5306 fixed gain Amp demo board simplifies the evaluation of the EL5306, a 350MHz bandwidth

high-speed amplifier. Its circuit configuration sets the gain of 2 on the demo board. For detail application, please refer to the EL5306 data sheet.

Features

- 350MHz Bandwidth for gain of +1, -1, and +2.
- Optional Selectable Gain (+1, -1, +2)
- Fully assemble and tested

Detailed Description

Voltage - Gain Adjustment

The EL5306's gain can be selected by changing the values of Jumpers on the demo board (see Table 1)

TABLE 1. RESISTOR VALUES FOR VARIOUS GAINS

GAIN (dB)	R1 (Ω)	R2 (Ω)	R3 (Ω)	R4 (Ω)	BANDWIDTH (MHz)
+1	0	open	0	open	250
-1	open	0	0	open	380
+2	0	open	open	0	350

Supply Operation

The EL5306 possess single and dual supply operation, from 5V to 10V. Each channel has a disable function. Upon being disabled, the outputs are tri-stated and the power supply current reduces to less than 12 μ A per amplifier. Allowing Enable Pin to float, or applying a low logic level will enable the amplifier.

Layout Considerations

The PC board layout has been optimized for high-speed signals. Careful attention was given to the signal paths, power supply bypassing, and grounding. All the input and output signal paths are 50 Ω MicroStrip line. The output resistor R_{OUT} is placed very close to the output pin to minimize the output stray capacitance. Small surface mount ceramic capacitors are placed as close as possible to the supply pins.

Evaluation Set Up

1. Use a \pm 5V supply. Connect the +5V to VS+ pin and the -5V to VS- pin. Connect power supply ground to the GND pin.
2. Supply a signal of \pm 1V at 1MHz to the INPUT SMA connector.
3. Connect the OUTPUT SMA connector to an oscilloscope through a 50 Ω cable.
4. Turn on the power supply and verify the output signal of 1V on the oscilloscope.

EL5306 Schematic

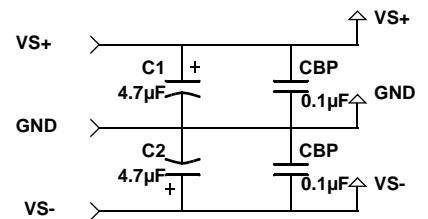
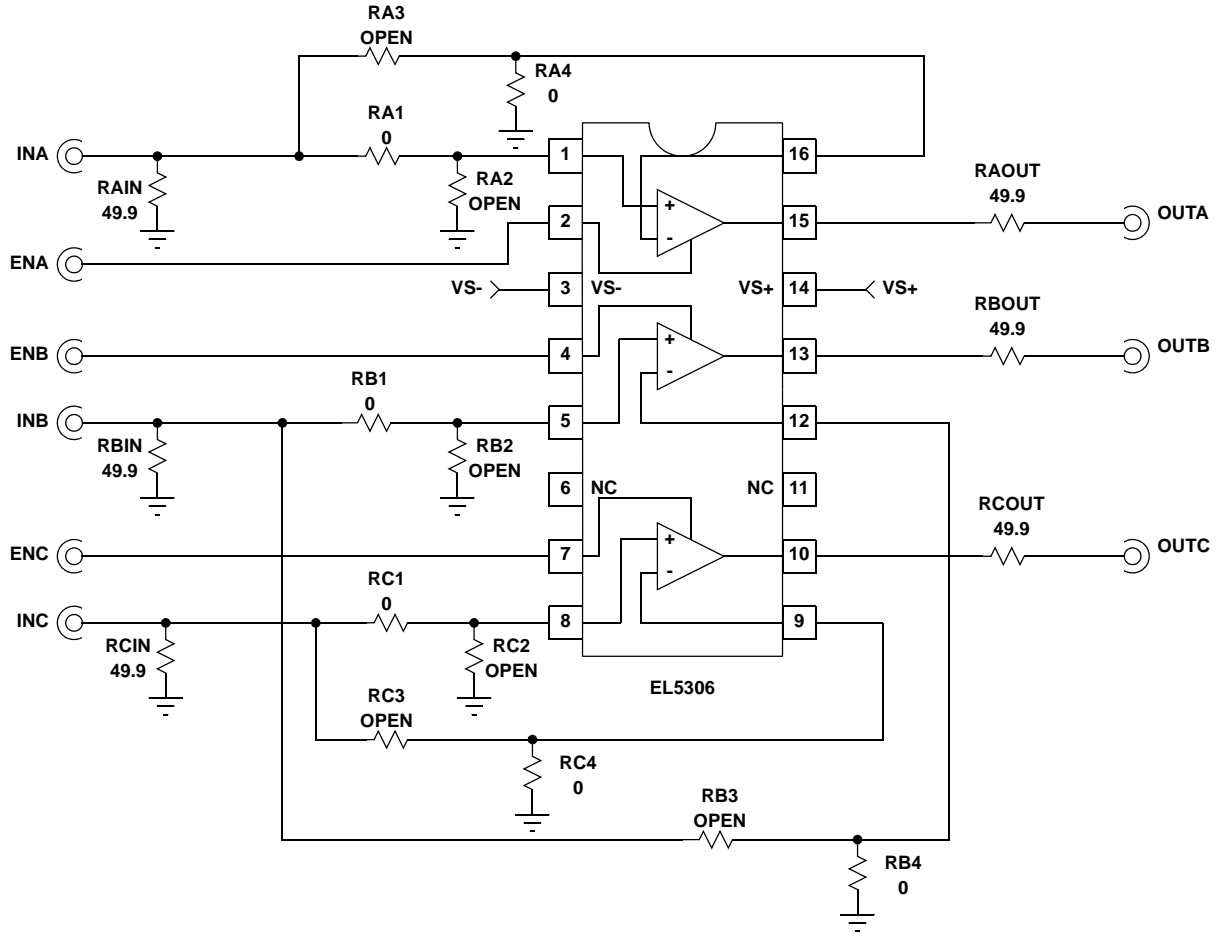

Technical Brief 441

EL5306 Bill of Materials

DESIGNATION	QTY	DESCRIPTION	MANUFACTURER	MFG. PART NUMBER
DUT	1	EL5306	Intersil	EL5306
PCB	1	Printed Circuit Board, SOIC 16	DDI	EL5396/7 Fixed Gain Amp
C1, C2	2	4.7 μ F, 10% Tantalum Capacitors	VISHAY	293D475X9016B2T
CBP	2	0.1 μ F, 20% Ceramic Capacitors	PHILIPS	08052E104M9BB0
RINA, RINB, RINC, REA, REB, REC, RAOUT, RBOUT, RCOUT	9	49.9 Ω , 1% Ceramic Resistors	R Ω	MCR10F49R9
RA1, RB1, RC1	3	0 Ω , 1% (install only for Av = +1, +2)	R Ω	MCR10F00R0
RA3, RB3, RC3	3	0 Ω , 1% (install only for Av = +1)	R Ω	MCR10F00R0
RA4, RB4, RC4	3	0 Ω , 1% (install only for Av = +2)	R Ω	MCR10F00R0
RA2, RB2, RC2, RA3, RB3, RC3	6	0 Ω , 1% (install only for Av = -1)	R Ω	MCR10F00R0
GND, VS+, VS-	3	Banana Jacks	SPC TECHNOLOGY	39N867
VINA, VINB, VINC, ENA, ENB, ENC, OUTA, OUTB, OUTC	9	SMA 50 Ω Straight Jack Connector	JOHNSON COMPONENTS	98F1467
	4	# 6 Internal Tooth Lock Washer	OLANDER	6NILWS
	4	6-32x.375"Lg., Phillips Pan Head	OLANDER	6C37PPMS
	4	6-32x.50"Lg., Hex Standoff, 1/4" Hex Dia	OLANDER	6C50HF4U

EL5306 Demo Board Layout

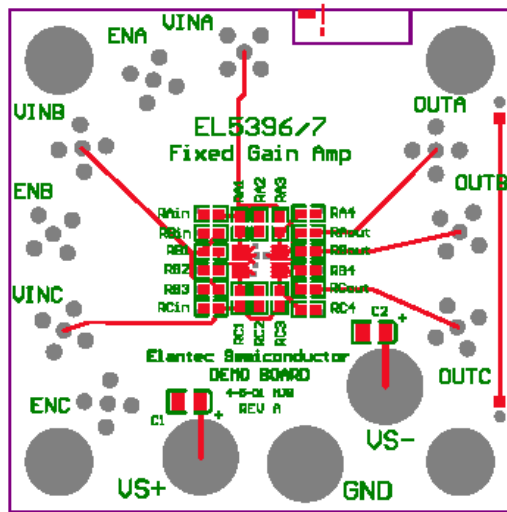

FIGURE 1. TOP LAYER

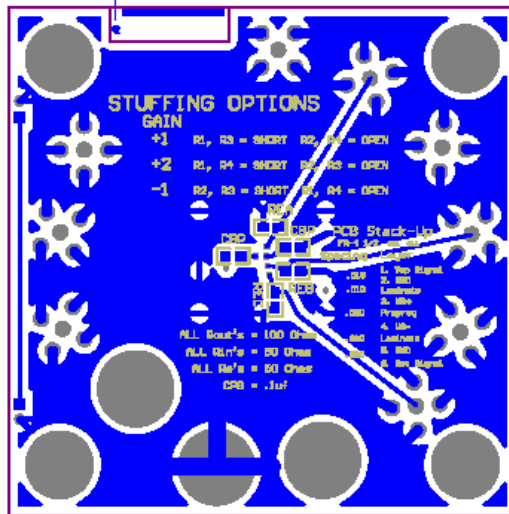

FIGURE 2. BOTTOM LAYER

Intersil Corporation reserves the right to make changes in circuit design, software and/or specifications at any time without notice. Accordingly, the reader is cautioned to verify that the Application Note or Technical Brief is current before proceeding.

For information regarding Intersil Corporation and its products, see www.intersil.com