

Introduction

***élan*tec**

The EL1528 is a dual channel differential amplifier designed for driving full rate ADSL signals at very low power dissipation. The high drive capability of 450mA makes this driver ideal for both CAP and DMT designs. It contains two pairs of wideband, high-voltage, current mode feedback amplifiers optimized for low power consumption in DSL systems.

One unique feature of the EL1528 is integrated protection circuitry designed to protect the driver outputs from transients such as electrostatic discharge (ESD) and lightning. In order to better understand the capability of the internal protection circuitry, it is useful to discuss a typical DSL architecture, the types and characteristics of the transients that a DSL circuit would encounter, and the Telecommunication Standards that apply to DSL circuits.

Transients

Transients are short-lived events in which an over voltage or over current condition occurs. In telecommunication equipment, transients that designers are most concerned with include Electrostatic Discharge (ESD), Lightning, and AC Power Faults or Power Cross.

Electrostatic Discharge (ESD)

ESD is caused by the transfer of electrical charge between any two objects caused by the imbalance of electrons on the surface of the two objects. The most common transfer is between the human body and any metallic or semiconducting surface. Such a transfer is very short in duration (<1ns) and can exceed 25kV. While this is generally harmless to the human, although it can smart a little, it has devastating effects on an integrated circuit. Most ICs have some level of ESD protection, but special attention must be placed on those I.C.'s that come in frequent contact with humans.

Lightning

Lightning is the most common cause of transients in telecommunication systems. Around the world, there are approximately 100 lightning strikes every second and since telecommunication lines are often exposed, there is great concern over the threat that lightning poses, not only to the telecommunications network, but to the humans that interface with them.

AC Power Faults

Power cross or AC power faults occur when AC power lines come in close proximity or even contact with telecom lines. In a power cross event (such as when a power line falls on a telephone line on a utility pole), the resulting transient can easily exceed 600VAC. Even if actual contact is not made, electromagnetic coupling between the AC power line and the telecom line can cause transients to enter the network.

Overview of Telecom and ESD Standards

Telecommunications Standards have been developed to provide greater reliability, prevent costly service interruptions and to allow users to safely operate Telecommunication Equipment – C.O. equipment, phones, fax machines, modems, etc. without the threat of personal injury due to electrical shock or fire.

Several standards for lightning and power cross in telecommunication systems exist including Telcordia GR-1089, UL60950, FCC 47 Part 68, and ITU-T K.20 & K.21. Table 1 summarizes the various tests that must be performed as defined by these standards.

One of the parameters defined for lightning or environmental testing is the wave shape. Figure 1 defines the lightning waveform and Table 1 defines the rise time and pulse duration. For example, for an 8x20 μ s waveform, T1 = 8 μ s and T2 = 20 μ s as defined in Figure 1. Also defined is the Surge Voltage, Surge Current and number of repetitions. Each surge is applied across Tip and Ring (Metallic) and from Tip/Ring to Earth Ground (Longitudinal).

Several standards for ESD also exist, but the mostly widely accepted standard is IEC-61000-4-2. The requirements are more severe than MIL-STD-883, Method 3015 and is now the preferred method worldwide.

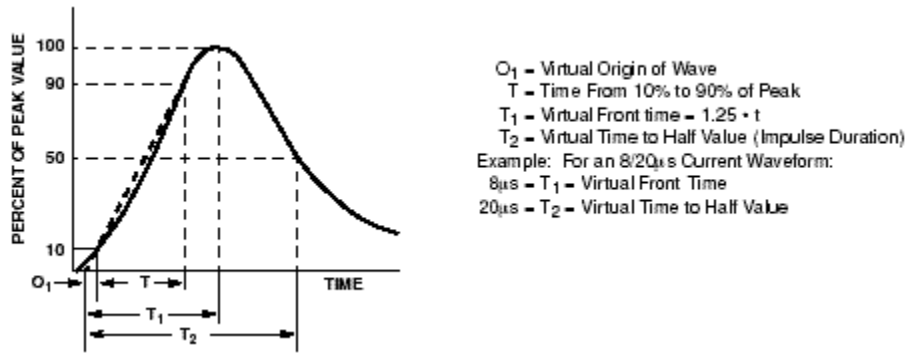

FIGURE 1. PEAK PULSE CURRENT TEST WAVEFORM

Comparison of Tests

Below are comparison charts for the various applicable standards. If the end equipment complies to Telcordia (Bellcore) GR-1089, FCC Part 68, and ULI 950, then generally it complies to ITU-T K.20 and K.21.

Environmental/Lightning

Must not be damaged and continue to operate after surge.

Standard	Surge Voltage (Vpk)	Wave-form (MS)	Surge Current per Conductor (A)	Repetitions Each Polarity
GR-1089 1st Level	+/- 600	10x1000	100	25
GR-1089 1st Level	+/-1000	10x360	100	25
GR-1089 1st Level	+/-1000	10x1000	100	25
GR-1089 1st Level	+/-2500	2x10	500	10
GR-1089 1st Level	+/-1000	10x360	25	5
FCC Part 68/Metallic B	+/-1000	9x720	25	1
FCC Part 68/Longitudinal B	+/-1500	9x720	37.5	1
ITU-T K.20	+/-1000	10x700	25	10
ITU-T K.21	+/-1500	10x700	75	10

Environmental/Lightning

Must not fragment, become fire, or an electrical safety hazard (referred to as passing "non-operationally").

Standard	Surge Voltage (Vpk)	Wave-form (MS)	Surge Current per Conductor (A)	Repetitions Each Polarity
GR-1089 2nd Level	+/- 5000	2x10	500	1
FCC Part 68/Metallic A	+/-800	10x560	100	1
FCC/Longitudinal A	+/-1500	10x160	200	1

AC Power Fault (Power Cross)

Must not fragment, become fire, or an electrical safety hazard (referred to as passing "non-operationally").

Standard	Voltage (Vrms)	Current (A)	Duration
GR-1089	120,277	30	15 Minutes
GR-1089	600	60	5 Seconds
GR-1089	600	7	5 Seconds
GR-1089	100-600	2.2A at 600V	15 Minutes
ULI 950	600	40	1.5 Seconds
ULI 950	600	7	5 Seconds
ULI 950	600	2.2A or just below interrupt rating of current interrupting device (Note)	30 Minutes
ULI 950	120	25	30 Minutes
ITU-T K.20	600	2	200 Milliseconds
ITU-T K.21	600	2	200 Milliseconds
ITU-T K.21	600	1	1 Second

Note: As an alternative procedure where a fuse causes an open circuit during test, the fuse may be bypassed and the available short circuit current applied set to 135% of the fuse rating.

TABLE 1. COMPARISON OF TELECOMMUNICATIONS TEST STANDARDS

Telcordia GR-1089-CORE

Telcordia (previously known as Bellcore) GR-1089, “Electromagnetic Compatibility and Electrical Safety Generic Criteria for Network Telecommunications Equipment,” was developed and is maintained by the Regional Bell Operating Companies and the Telecom industry. Telcordia GR-1089 is more comprehensive than other specifications addressing both equipment performance and safety issues and covering the requirements for telecommunications equipment connected to the outside world through twisted pair copper wire. The standard consists of first level stresses for which equipment must remain functional and second level stresses that must not create a fire, fragmentation, or electrical safety hazard.

UL1459/1950/60950

UL1459 was the original UL standard covering Telecommunication equipment whose primary function was to protect users of telecom equipment. UL1950 and most recently UL60950 was developed as a bi-national standard with CSA based on IEC950 and including the requirements of UL1459. Most local governments require UL60950 compliance to meet the National Electric Code (NEC), giving UL60950 the force of law.

FCC 47 Part 68

The rules of FCC 47 Part 68 are intended to ensure that equipment attached to the network will not harm the network. It does not specifically address safety issues, but rather is a performance specification.

ITU-T K.20 & K.21

These standards are recognized in Europe and Asia and are designed to address reliability of equipment. ITU-T K.20 and K.21 standards address telephone exchanges, switching centers, and customer premise equipment that may or may not be in an exposed environment. The standard consists of lightning simulation, inducted power and power contact tests.

IEC61000-4-2

The IEC 61000-4-2 defines several levels of severity. The levels are separately defined for plus and minus polarity of direct contact discharge (preferred) and air discharge as shown in Table 2. Other voltage levels may be specified for the IEC 61000-4-2 test equipment and conditions. Figure 2 shows the IEC defined ESD waveform. Note the extremely fast rise time.

LEVEL	TEST VOLTAGE, kV CONTACT DISCHARGE	TEST VOLTAGE, kV AIR DISCHARGE
1	2	2
2	4	4
3	6	8
4	8	15

TABLE 2. IEC 61000-4-2 SEVERITY LEVELS

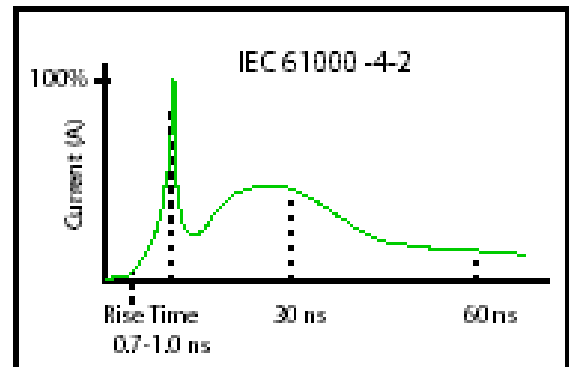

FIGURE 2. IEC61000-4-2 ESD WAVEFORM

Reference Designs and System Compliance

Now that we have a better understanding of the standards to which a designer of DSL systems must comply, it is useful to discuss a typical DSL reference design including the components that are necessary to help aid in this compliance.

Figure 3 shows a typical simplified EL1507, EL1508 line driver reference design. 2 pairs of Schottky diodes are used

to clamp the outputs of the line driver to a diode voltage within the $\pm 12V$ supply of the line driver.

Figure 4 shows a similar design, but the EL1507, EL1508 are replaced by the dual DSL driver EL1528 with internal protection circuitry. Note the protection Schottky's are removed as the intention of this application note is test the capability of the internal protection circuitry.

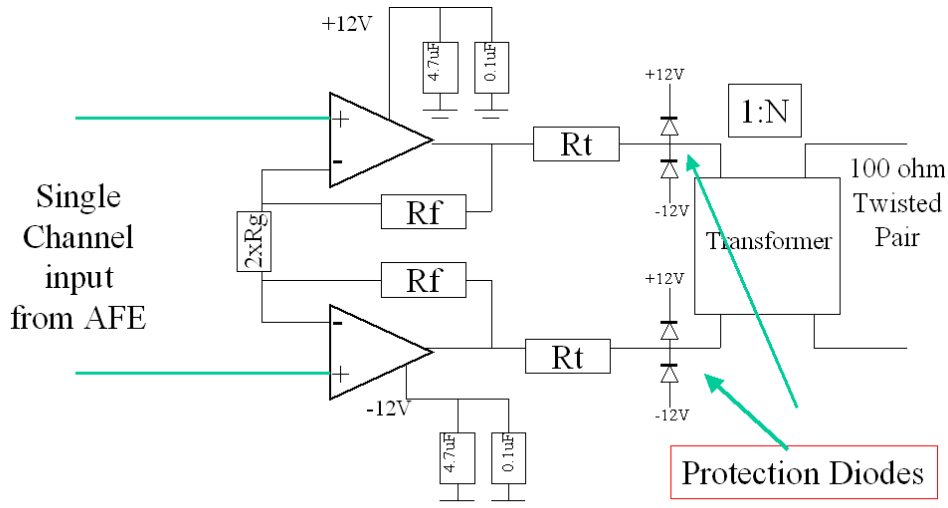

FIGURE 3. EL1507, EL1508 LINE INTERFACE CIRCUIT WITH SCHOTTKY PROTECTION DIODE

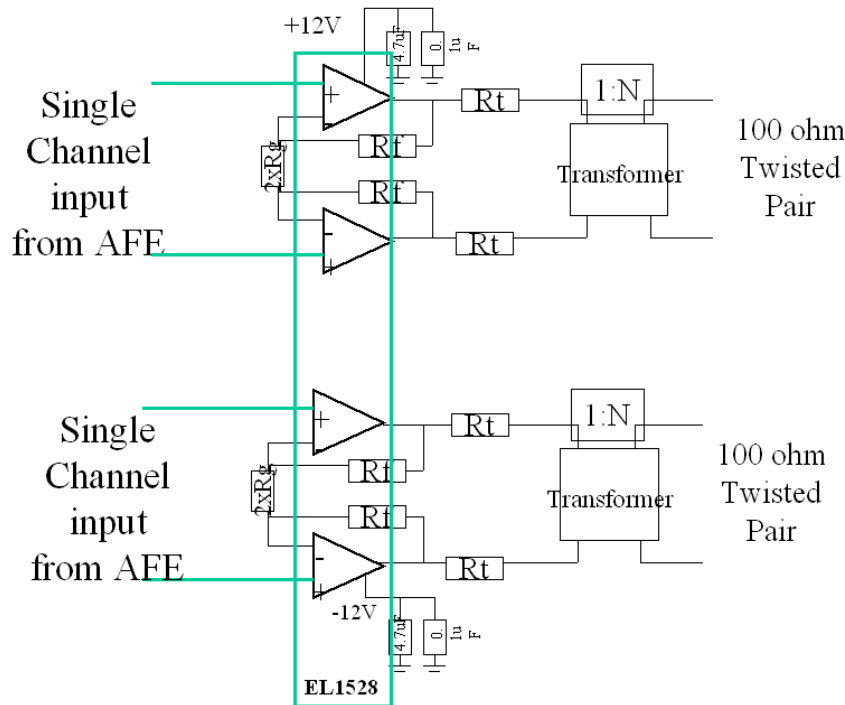

FIGURE 4. EL1528 LINE INTERFACE CIRCUIT WITHOUT SCHOTTKY PROTECTION DIODE

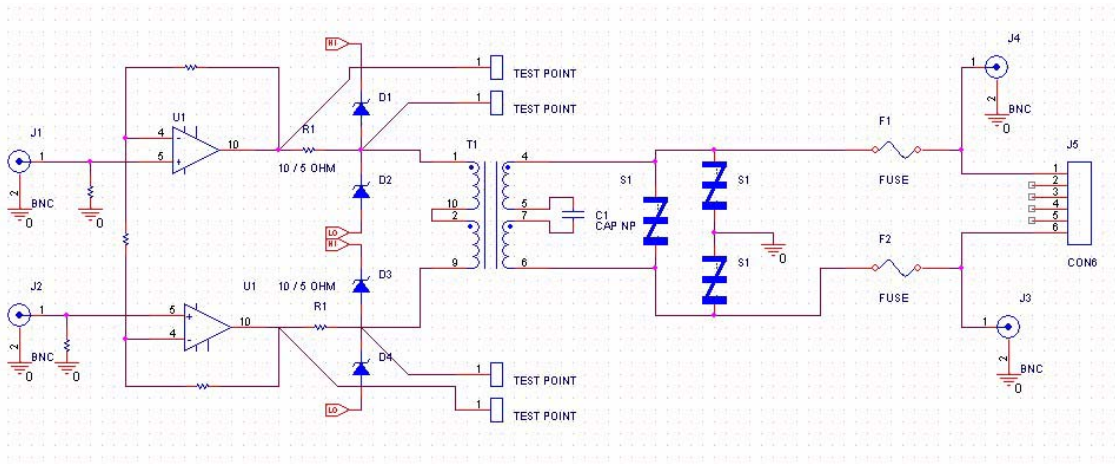

FIGURE 5. LIGHTNING SURGE TEST CIRCUIT

Test Set-up

Figure 5 shows the complete lightning surge test setup. S1, S2, and S3 are Teccor Sidactors (P2300SA) to aid in protection against metallic and longitudinal transients. F1 and F2 are Teccor Telecom Fuses (F1250T). These fuses are specifically designed to withstand the Environmental Testing without damage, but clear when necessary during a power cross event. T1 is a DSL transformer. D1-D4 are Shotkky Diodes that help clamp any transient energy that may get coupled through the transformer. For the EL1528 test, D1-D4 diodes are removed. The series resistor varies depending on the reference design, but 5Ω is typically the smallest value used.

Test Waveforms

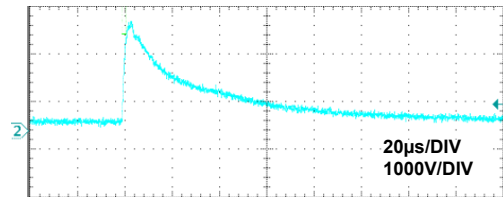

FIGURE 6. TIP AND Ring VOLTAGE, TIP GROUND, Ring 2500V, 2/10µs

Figure 6 is the worst case lightning test with 2500V applied across the ring and tip terminals on the line side.

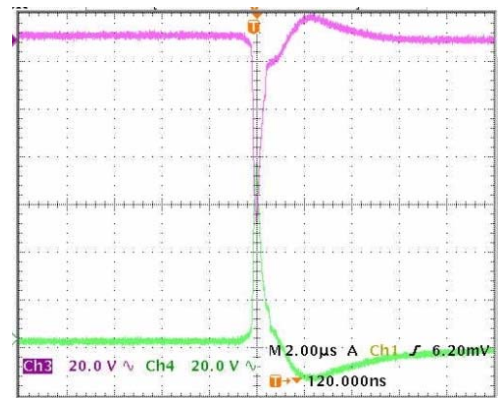

FIGURE 7. VOLTAGES ON THE LINE DRIVER SIDE OF TRANSFORMER, TIP GROUND, Ring 2500V

Figure 7 shows the voltages on the line driver side of the transformer, the lightning surge is Tip at ground and Ring at 2500V, time duration is 2/10µs. The voltage coupled to the line driver side after the Sidactor and isolation transformer is over 160V differential.

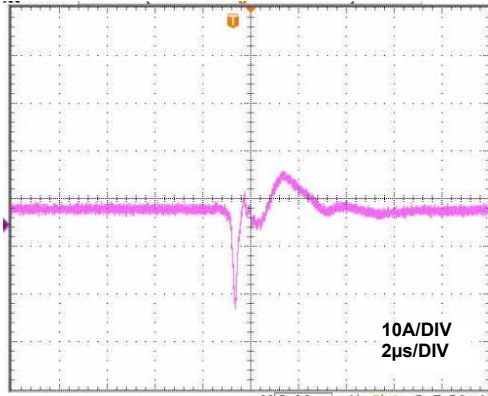

FIGURE 8. LIGHTNING SURGE CURRENT INTO EL1528 WITH 5Ω RBM, TIP GROUND, Ring 2500V

Figure 8 shows over 20A of current going in and out of the EL1528 when 2500V of lightning surge voltage is applied. The output current is measured with 5Ω of RBM (back match resistor). With 10Ω of RBM, the output current spike is reduced by 2X.

EL1528 Lightning Surge Test Results

TABLE 3. EL1528 LIGHTNING SURGE TEST RESULTS

DEVICE #	DATECODE	PB-MIL	BEFORE/ AFTER	RBT	IS+	IS-	THD-A-2.5	THD-B-2.5	THD-A-2.85	THD-B-2.85	COMMENTS
2	0226A	MIL	Before	10	17.2	16.2	68.5	68.9	49.8	49.7	
2	0226A	MIL	After	10	17.2	16.22	No output				Blown 10Ω RBT
5	0239A	PB	Before	10	18.22	17.16	69.2	69.2	49.3	50.5	
5	0239A	PB	After	10	10.21	17.15	71.7	71.7	48.4	49.5	Blown -12V Power Supply Fuse
6	0239A	PB	Before	10	18.37	17.29	67.8	68	49.3	49.9	
Device #	Datecode	PB-MIL	Before/ After	RBT	Is+	Is-	THD-A-2.5	THD-B-2.5	THD-A-2.85	THD-B-2.85	Comments
6	0239A	PB	Before	5	18.37	17.29	70.8	70.7	43.1	41.4	RBT changed to 5Ω
6	0239A	PB	After	5	18.33	17.2	68.8	69	47.1	46.9	
1	0239A	PB	Before	10	18.55	17.46	69.7	69.7	49.5	50.5	10Ω 2010 Resistor
1	0239A	PB	After	10	18.51	17.46	69.7	69.7	49.1	51.1	
3	0226A	MIL	Before	5	17.48	16.57	68.8	68.8	51.4	47.8	5Ω 2010 Resistor
3	0226A	MIL	After	5	17.55	16.57	68	67.9	53.4	48.9	

To qualify the survival of the EL1528, in addition to the ATE product test, we also test the device supply current and distortion. As shown in table 3, the EL1528 were tested with 5Ω and 10Ω backmatch resistors. The linearity performance of the device remains unchanged after the lightning surge test.

Intersil Corporation reserves the right to make changes in circuit design, software and/or specifications at any time without notice. Accordingly, the reader is cautioned to verify that the Application Note or Technical Brief is current before proceeding.