

Introduction

Many surface mounted devices (SMD) are being packaged for shipment in embossed tape and wound onto reels. The Intersil Tape and Reel specifications are in compliance with Electronics Industries Association Standards for “Embossed Carrier Taping of Surface Mount Components for Automatic Handling”.

- EIA-481 for the 8, 12, 16, 24, 32, 44 and 56mm Wide Tape

Intersil now supplies many different SMDs in Tape and Reel, as shown in Table 1.

TABLE 1. PACKAGE AND TAPE SPECIFICATIONS

PACKAGE TYPE	NO. OF LEADS	NOMINAL PACKAGE SIZE	UNITS PER REEL	REEL & HUB SIZE (Note 3)	TRAILER "A"		LEADER "B"		POCKET TAPE (mm)	
					POCKETS	LENGTH (mm)	POCKETS	LENGTH (mm)	WIDTH	PITCH (P1)
SOIC(N) (SOPN)	8	0.155x0.194mm	2500/1000	13&4/7&2.4	77	616	77	616	12	8
SOIC(N) (SOPN)	14	0.155x0.342mm	2500/1000	13&4/7&2.4	77	616	77	616	16	8
SOIC(N) (SOPN)	16	0.155x0.391mm	2500/1000	13&4/7&2.4	77	616	77	616	16	8
SOIC(W) (SOPW)	16	0.296x0.407mm	1,000	13&4	34	420	45	552	16	12
SOIC(W) (SOPW)	18	0.296x0.456mm	1,000	13&4	34	420	45	552	24	12
SOIC(W) (SOPW)	20	0.296x0.506mm	1,000	13&4	34	420	45	552	24	12
SOIC(W) (SOPW)	24	0.296x0.606mm	1,000	13&4	34	420	45	552	24	12
SOIC(W) (SOPW) (or EPSOIC)	28	0.296x0.706mm	1,000	13&4	26	416	34	544	32	16
EIAJ SOIC	8	0.217x0.217mm	2,500	13&4	77	616	77	616	12	8
MSOP	8/10	3.0x3.0mm	2500/1000	13&4/7&2.4	77	616	77	616	12	8
TSSOP	8	4.4x3.0mm	2500/1000	13&4/7&2.4	77	616	77	616	12	8
TSSOP	14/16	4.4x5.0mm	2500/1000	13&4/7&2.4	77	616	77	616	12	8
TSSOP	20	4.4x6.5mm	2500/1000	13&4/7&2.4	77	616	77	616	16	8
TSSOP (or EPTSSOP)	24	4.4x7.8mm	2500/1000	13&4/7&2.4	77	616	77	616	16	8
TSSOP (or EPTSSOP)	28/38	4.4x9.7mm	2500/1000	13&4/7&2.4	77	616	77	616	16	8
QSOP (SSOP)	16	0.155x0.194mm	2500/1000	13&4/7&2.4	77	616	77	616	12	8
QSOP (SSOP)	20/24	0.155x0.342mm	2500/1000	13&4/7&2.4	77	616	77	616	16	8
QSOP (SSOP)	28	0.155x0.391mm	2500/1000	13&4/7&2.4	77	616	77	616	16	8
SSOP	16	0.209x0.244mm	1,000	13&4	24	420	45	552	16	12
SSOP	20	0.209x0.284mm	1,000	13&4	34	420	45	552	16	12
SSOP	24	0.209x0.323mm	1,000	13&4	34	420	45	552	16	12
SSOP	28	0.209x0.402mm	1,000	13&4	34	420	45	552	24	12
PLCC	20	0.350x0.350mm	1,000	13&4	53	660	64	792	16	12
PLCC	28	0.450x0.450mm	750	13&4	15	256	25	416	24	16
PLCC	32	0.450x0.550mm	750	13&4	15	256	25	416	24	16
PLCC	44	0.650x0.650mm	500	13&4	15	384	25	624	32	24
PLCC	68	0.950x0.950mm	250	13&6	25	832	25	832	44	32
PLCC	84	1.150x1.150mm	200	13&6	25	936	25	936	44	36

Technical Brief 347

TABLE 1. PACKAGE AND TAPE SPECIFICATIONS (Continued)

PACKAGE TYPE	NO. OF LEADS	NOMINAL PACKAGE SIZE	UNITS PER REEL	REEL & HUB SIZE (Note 3)	TRAILER "A"		LEADER "B"		POCKET TAPE (mm)	
					POCKETS	LENGTH (mm)	POCKETS	LENGTH (mm)	WIDTH	PITCH (P1)
TQFP	32	5x5 x1.0mm	2,000	13&6	33	400	33	400	16	12
TQFP/EPAD TQFP	32/48	7x7x1.0mm	1,000	13&6	34	420	45	552	16	12
TQFP EPAD	64	10x10x1.0mm	1,000	13&4	26	420	35	552	24	16
TQFP	64	10x10x1.0mm	1,000	13&6	25	400	30	480	24	16
TQFP	80	14x14x1.0mm	1,000	13&4	10	240	20	480	24	24
LQFP	48	7x7x1.4mm	1,000	13&6	34	420	45	552	16	12
LQFP	64	10x10x1.4mm	1,000	13&6	25	400	30	480	24	16
LQFP	80	14x14x1.4mm	500	13&4	21	420	28	552	32	24
LQFP	128	14x20x1.4mm	1000	13&4	10	160	20	390	44	24
LQFP (or PQLQP)	144	20x20x1.4mm	600	13&6	15	320	25	640	44	32
MQFP	44	10x10x2.0mm	500	13&6	25	624	25	624	24	24
MQFP	80	14x20x2.7mm	500	13&6	10	193	20	385	44	24
PBGA (fBGA)	160/196	12x12x1.4mm	1,000	13&6	25	400	30	480	24	16
PBGA (fBGA)	192	14x14x1.32mm	1,000	13&6	10	240	20	480	24	24
PBGA (fBGA)	196	15x15x1.4mm	750	13&6	10	240	20	480	24	24
PBGA (fBGA)	256/316	17x17x1.4mm	500	13&6	10	240	20	480	24	24
TDFN	Note 4	2x3x0.75mm	6,000	13&4	77	616	77	616	12	8
TDFN	Note 4	3x3x0.75mm	6,000	13&4	77	616	77	616	12	8
TDFN	Note 4	4x3x0.75mm	6000/2500/1000	13&4/13&4/ 7&2.4	77	616	77	616	12	8
TDFN	Note 4	4x4x0.75mm	6,000	13&4	77	616	77	616	12	8
DFN	Note 4	2x3x0.9mm	6,000	13&4	77	616	77	616	12	8
DFN	Note 4	3x3x0.9 mm	6000/2500/1000	13&4/13&4/ 7&2.4	77	616	77	616	12	8
DFN	Note 4	4x3x0.9mm	6,000	13&4	77	616	77	616	12	8
DFN	Note 4	4x4x0.9mm	6000/2500/1000	13&4/13&4/ 7&2.4	77	616	77	616	12	8
DFN	Note 4	4x5.5x1.3mm	4,000	13&4	77	616	77	616	12	8
QFN/TQFN	Note 4	3x3x0.9/0.75mm	6,000	13&4	77	616	77	616	12	8
QFN (Zilker Lab)	Note 4	3x3x0.9 mm	1000/100	13&4/7&2.4	20	160	50	400	12	8
QFN/TQFN	Note 4	3.5x3.5x0.9/0.75mm	6,000	13&4	77	616	77	616	12	8
QFN/TQFN	Note 4	4x4x0.9/0.75mm	6000/2500/1000	13&4/13&4/ 7&2.4	77	616	77	616	12	8
QFN/TQFN	Note 4	4x5x0.9/0.75mm	6000/2500	13&4	77	616	77	616	12	8
QFN/TQFN	Note 4	5x5x0.9/0.75mm	6000/2500/1000	13&4/13&4/ 7&2.4	77	616	77	616	12	8
QFN (Zilker Lab)	Note 4	5x5x0.9 mm	1000/100	13&4/7&2.4	20	160	50	400	12	8
QFN/TQFN	Note 4	5x7x0.9/0.75mm	2500/1000	13&4/7&2.4	20	160	48	390	16	8

Technical Brief 347

TABLE 1. PACKAGE AND TAPE SPECIFICATIONS (Continued)

PACKAGE TYPE	NO. OF LEADS	NOMINAL PACKAGE SIZE	UNITS PER REEL	REEL & HUB SIZE (Note 3)	TRAILER "A"		LEADER "B"		POCKET TAPE (mm)	
					POCKETS	LENGTH (mm)	POCKETS	LENGTH (mm)	WIDTH	PITCH (P1)
QFN	Note 4	5x6x0.9mm	2500/1000	13&4/7&2.4	77	616	77	616	12	8
QFN/TQFN	Note 4	5x10x0.9/0.75mm	4,000	13&4	34	420	45	552	24	12
QFN/TQFN	Note 4	6x6x0.9/0.75mm	4000/2500/1000	13&4/13&4/7&2.4	34	420	45	552	16	12
QFN (Zilker Lab)	Note 4	6x6x0.9mm	1000/100	13&4/7&2.4	14	160	34	400	16	12
QFN/TQFN	Note 4	7x7x0.9/0.75mm	4,000	13&4	34	420	45	552	16	12
QFN/TQFN	Note 4	8x8x0.9/0.75mm	4,000	13&4	34	420	45	552	16	12
QFN/TQFN	Note 4	9x9x0.9/0.75mm	4,000	13&4	34	408	45	540	16	12
QFN/TQFN	Note 4	10x10x0.9/0.75mm	3,000	13&4	26	416	34	544	24	16
QFN	Note 3	15x15x3.5mm	500	13&4	20	400	20	400	12	20
MO-169 (TO-262)	3/7	0.400 x0.415	800	13&4	50	800	50	800	24	16
SOT-23	3	0.051x0.115	3000/250	7&2.4	40	160	100	400	8	4
SOT-23	5/6/8	0.065x0.115	3000/250	7&2.4	63	250	126	500	8	4
SC70	3	0.049x0.079	3000/250	7&2.4	40	160	100	400	8	4
SC70	5/6	0.049x0.079	3000/250	7&2.4	95	380	125	500	8	4
WLCSP	4	1.16x0.98mm	3,000	7&2.4	95	380	125	500	8	4
WLCSP	6	1.0x1.5mm	3,000	7&2.4	95	380	125	500	8	4
WLCSP	9	1.45x1.45mm	3,000	7&2.4	95	380	125	500	8	4
WLCSP	9	1.32x1.54mm	3,000	7&2.4	95	380	125	500	8	4
WLCSP	12	1.48 x1.98mm	3,000	7&2.4	95	380	125	500	8	4
WLCSP	12	1.70x1.30mm	3,000	7&2.4	95	380	125	500	8	4
WLCSP	20	2.55x2.05mm	3,000	7&2.4	95	380	125	500	8	4
WLCSP	36	2.53x2.53mm	3,000	7&2.4	95	380	125	500	8	4
µTDFN	6	1.2x1.0x0.50	3,000	7&2.4	100	400	100	400	8	4
µTDFN	6	1.6x1.6x0.50	3,000	7&2.4	100	400	100	400	8	4
µTDFN	8	2.0x2.0x0.50	3,000	7&2.4	100	400	100	400	8	4
µTQFN	10	1.8x1.4x0.50	3,000	7&2.4	100	400	100	400	8	4
µTQFN	10	2.1x1.6x0.50	3,000	7&2.4	100	400	100	400	8	4
µTQFN	12	2.2x1.4x0.50	3,000	7&2.4	100	400	100	400	8	4
µTQFN	16	2.6x1.8x0.50	3,000	7&2.4	100	400	100	400	8	4
µTQFN	20	3.2x1.8x0.50	3,000	7&2.4	100	400	100	400	8	4
ODFN	4	1.5x1.5x0.70	3,000	7&2.4	40	160	100	400	8	4
ODFN	5/6	2.0x2.1x0.70	3,000	7&2.4	40	160	100	400	8	4
ODFN	8	3.0x3.0x0.70	1,000	7&2.4	40	160	100	400	8	4

NOTES:

1. Pocket count and trailer and leader lengths are nominal counts/dimensions.
2. Package size in inches (unless otherwise indicated).
3. Reel & hub size; Example: 13&4 = 13 inch reel with 4 inch hub.
4. Multiple lead counts

General Information

The Intersil Tape and Reel packing system protects the product from mechanical and electrical damage and is designed for automatic pick-and-place equipment.

The Tape and Reel packing system consists of a Pocket Carrier Tape sealed with a protective Cover Tape to hold the devices in place.

The devices are loaded with leads down, into the carrier pockets.

The tape is wound onto a plastic reel for Labeling and Packing for shipment.

All tape sizes are supplied on 7in and 13in diameter reels.

The conductive Carrier Tape, and antistatic coated Transparent Cover Tape and Reel provide ESD protection.

Information Labels, ESD Labels and Barcode Labels (if required) are placed on each reel.

Transparent Cover Tape allows device verification and brand inspection without having to remove or handle components.

No more than 2 date codes will be combined on any one reel.

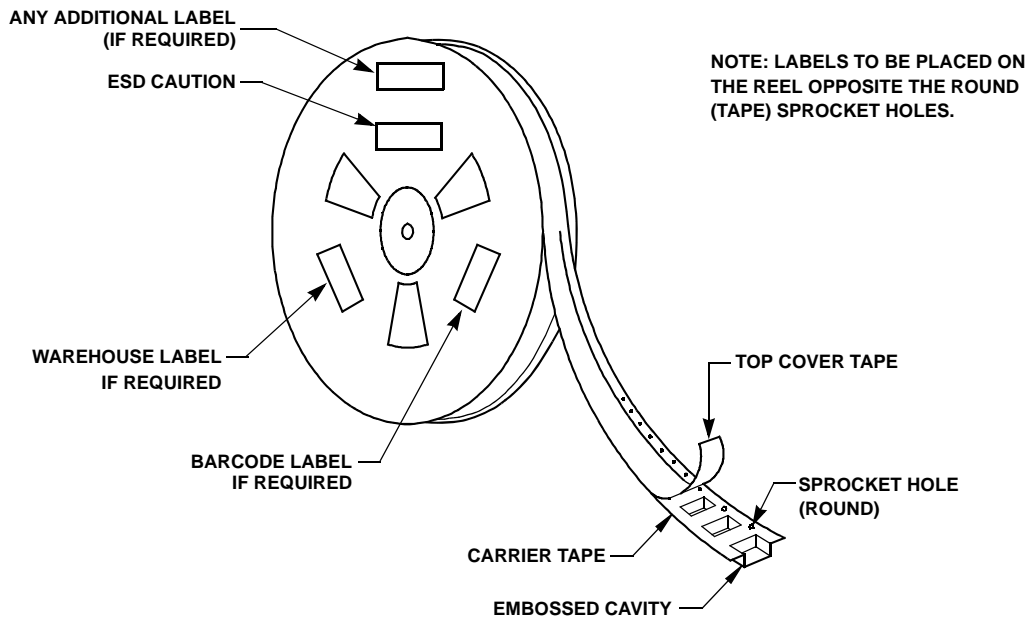

FIGURE 1. TAPE/REEL AND LABEL INFORMATION

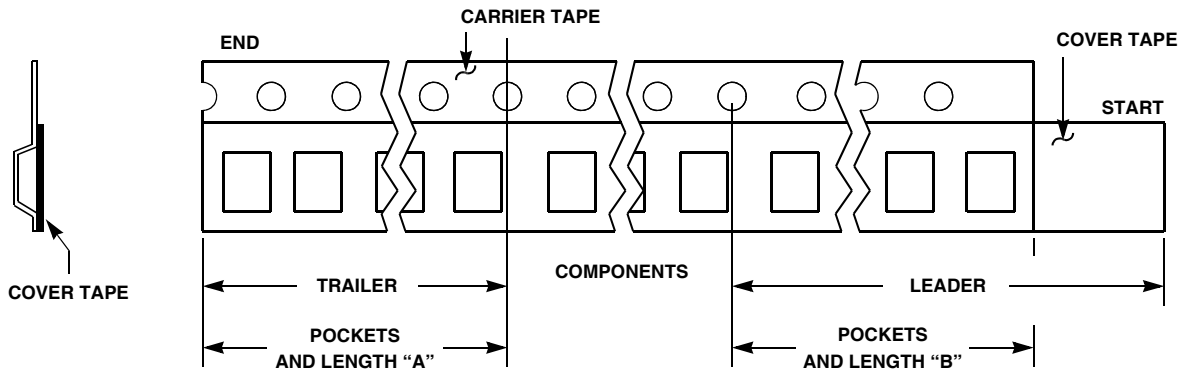

FIGURE 2. TAPE LEADER AND TRAILER

Materials and Design

Carrier Tape

The Pocketed Carrier Tape is made of Conductive Polystyrene + Carbon material (or equivalent). The surface resistivity is $10^6 \Omega/\text{Sq}$. Maximum.

Pocket Tapes are designed in such a manner that the components remain in position for automatic handling after the removal of the cover tape.

Each pocket has a hole in the center for automated sensing of whether or not the pocket is occupied, thus facilitating device removal.

Sprocket holes along the edge of the carrier tape enable direct feeding into automated board assembly equipment.

See Figures 3 and 4 for Carrier Tape dimensions.

Cover Tape

The Cover Tape is made of Antistatic Transparent Polyester Film.

The surface resistivity is $10^7 \Omega/\text{Sq}$. minimum to $10^{11} \Omega/\text{Sq}$. Maximum.

The Cover Tape is heat-sealed to the edges of the Carrier Tape to encase the devices in the pockets.

The force to peel back the Cover Tape from the Carrier Tape shall be a MEAN value of 30 to 80gm (0.3N to 0.8N).

Reel

The device loading orientation is in compliance with EIA-481. (See Figure 5).

The loaded Carrier Tape is wound onto a reel that is uniformly sized for all packages. (See Figure 6).

The Reel is made of Antistatic High Impact Polystyrene. The surface resistivity $10^7 \Omega/\text{Sq}$. minimum to $10^{11} \Omega/\text{Sq}$. Maximum.

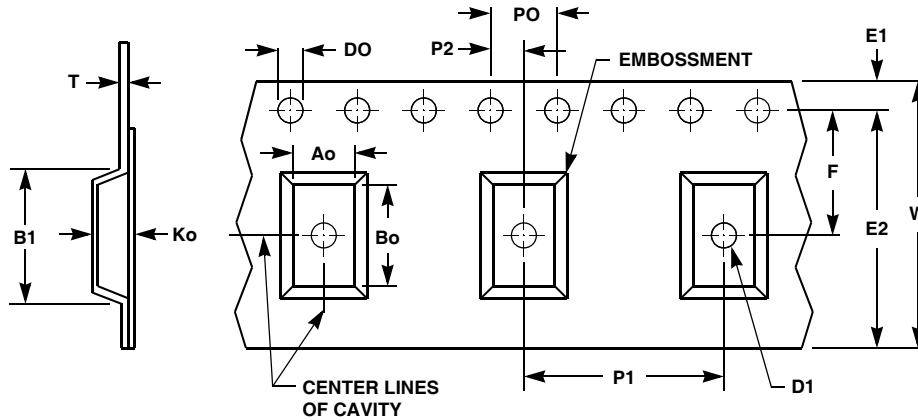

FIGURE 3. CONFIGURATION DRAWING FOR 8, 12, 16, 24mm POCKET TAPE

W (NOMINAL) TAPE WIDTH	(NOTE 9) B1 (MAXIMUM)	F (NOMINAL)	E2 (MINIMUM)
8mm (0.315)	4.35 (0.171)	3.5 (0.138)	6.25 (0.246)
12mm (0.472)	8.2 (0.323)	5.5 (0.217)	10.25 (0.404)
16mm (0.629)	12.1 (0.476)	7.5 (0.295)	14.25 (0.561)
24mm (0.945)	20.1 (0.791)	11.5 (0.453)	22.25 (0.876)

NOTES:

5. Dimensions are in millimeters and are nominal unless otherwise indicated (inches are in brackets for reference only).
6. "T" dimension, nominal 0.30 or 0.35.
7. "P1" cavity pitch is 8.0mm min. and increases in 4.0mm increments depending on package size. (See Table 1).
8. "P0" dimension is 4.0mm.
9. "P2" dimension is 2.0mm.
10. "B1" actual dimension is determined by package size.
11. "D1" diameter is 1.5mm min.
12. "Do" diameter is 1.5mm.
13. "E1" dimension is 1.75mm.
14. "Ao", "Bo", "Ko" dimensions determined by component size.

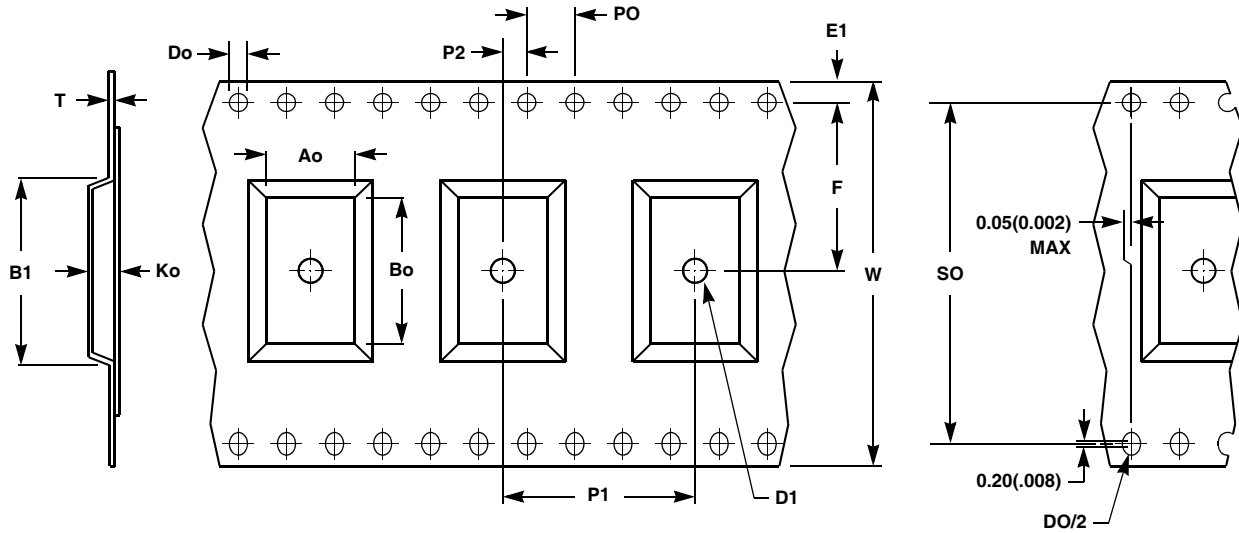

FIGURE 4. CONFIGURATION DRAWING FOR 32mm AND 44mm POCKET TAPE

W (NOMINAL) TAPE WIDTH	(NOTE 19) B1 (MAXIMUM)	F (NOMINAL)	SO (NOMINAL)
32mm (1.260)	23.0 (0.906)	14.2 (0.559)	28.4 (1.118)
44mm (1.732)	35.0 (1.378)	20.2 (0.795)	40.4 (1.591)

NOTES:

15. Dimensions are in millimeters and are nominal unless otherwise indicated (inches are in brackets for reference only).
16. "T" dimension, nominal 0.30 or 0.35.
17. "P1" cavity pitch is 8.0mm min. and increases in 4.0mm increments depending on package size. (See Table 1).
18. "P0" dimension is 4.0mm.
19. "P2" dimension is 2.0mm.
20. "B1" actual dimension is determined by package size.
21. "D1" diameter is 2.0mm min.
22. "Do" diameter is 1.5mm.
23. "E1" dimension is 1.75mm.
24. "Ao", "Bo", "Ko" dimensions determined by component size.

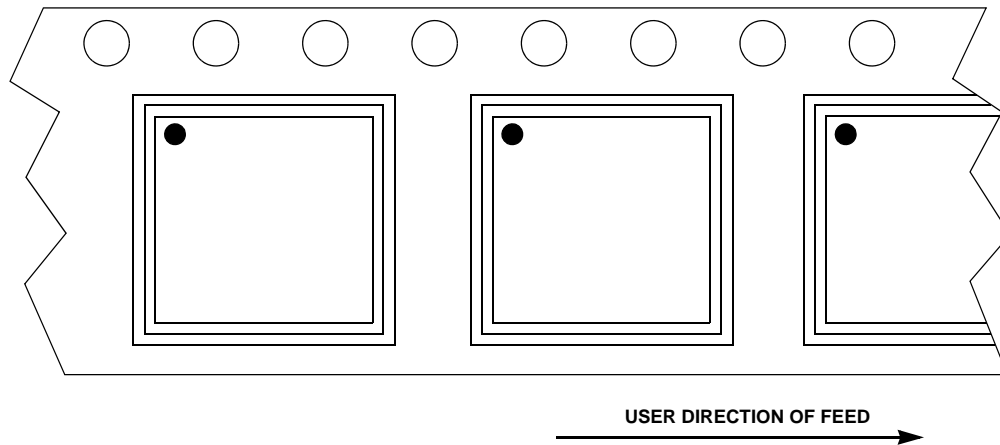

FIGURE 5A. SQUARE - BGA, QFN AND DFN

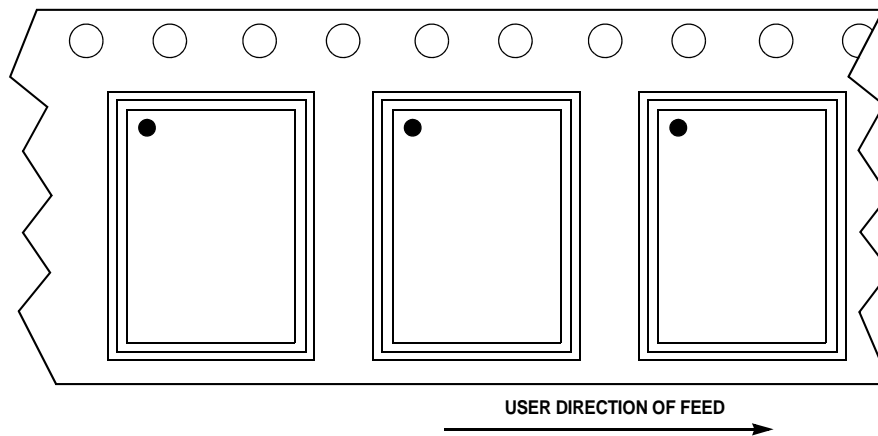

FIGURE 5B. RECTANGULAR - QFN AND DFN

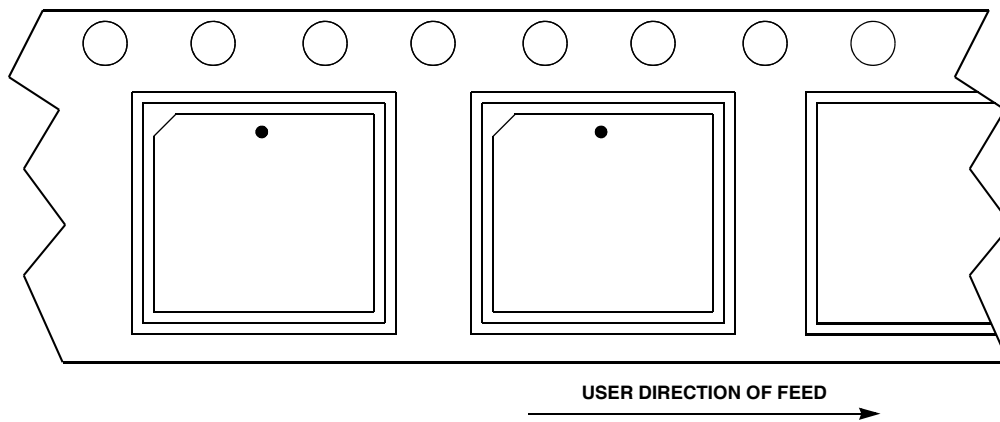

FIGURE 5C. PLCC

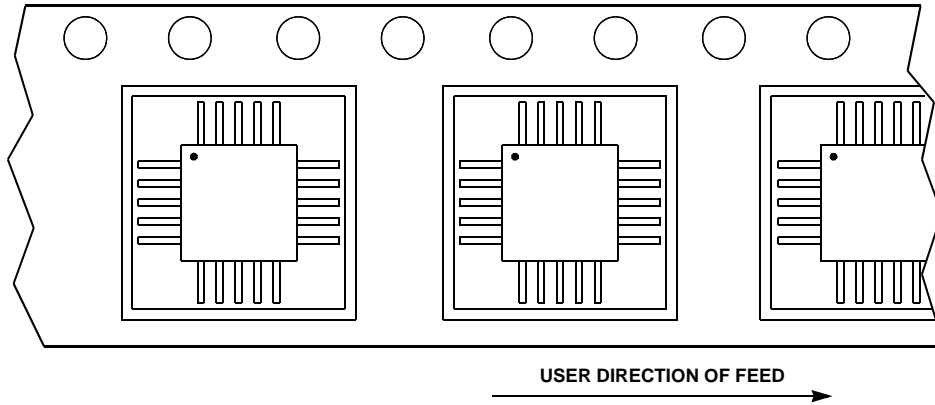

FIGURE 5D. SQUARE - MQFP, TQFP AND LQFP

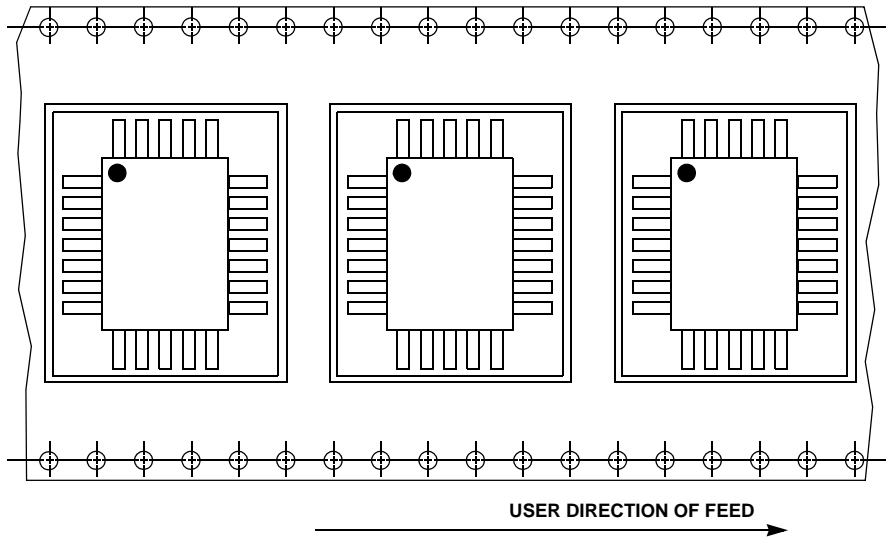

FIGURE 5E. RECTANGULAR - MQFP, TQFP AND LQFP

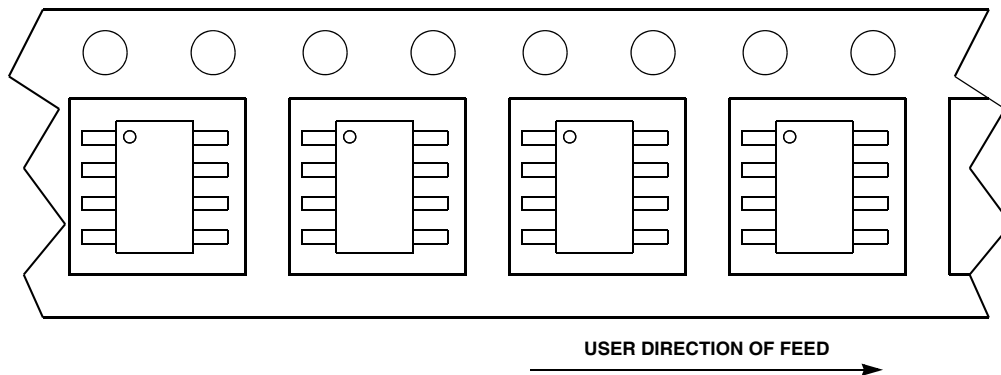

FIGURE 5F. SOIC, MSOP, TSSOP, QSOP AND PSOP

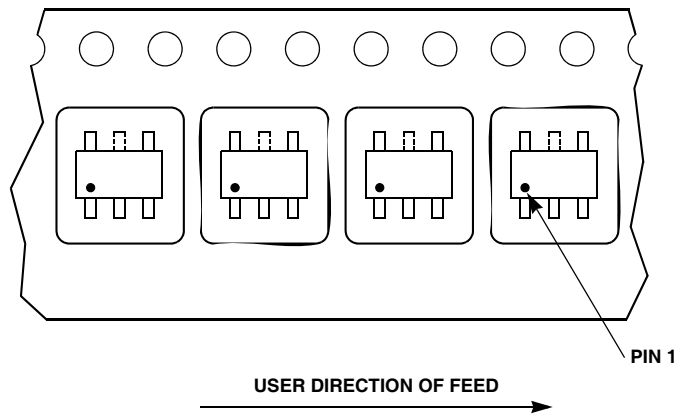

FIGURE 5G. SOT-23 & SC-70

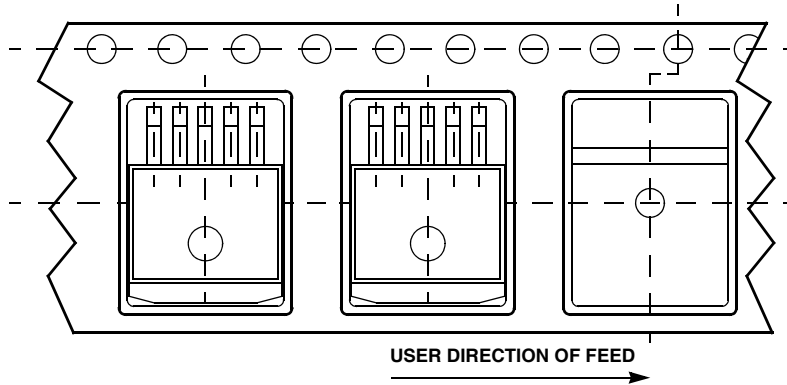

FIGURE 5H. MO-169

FIGURE 5. MECHANICAL POLARIZATION DIAGRAMS

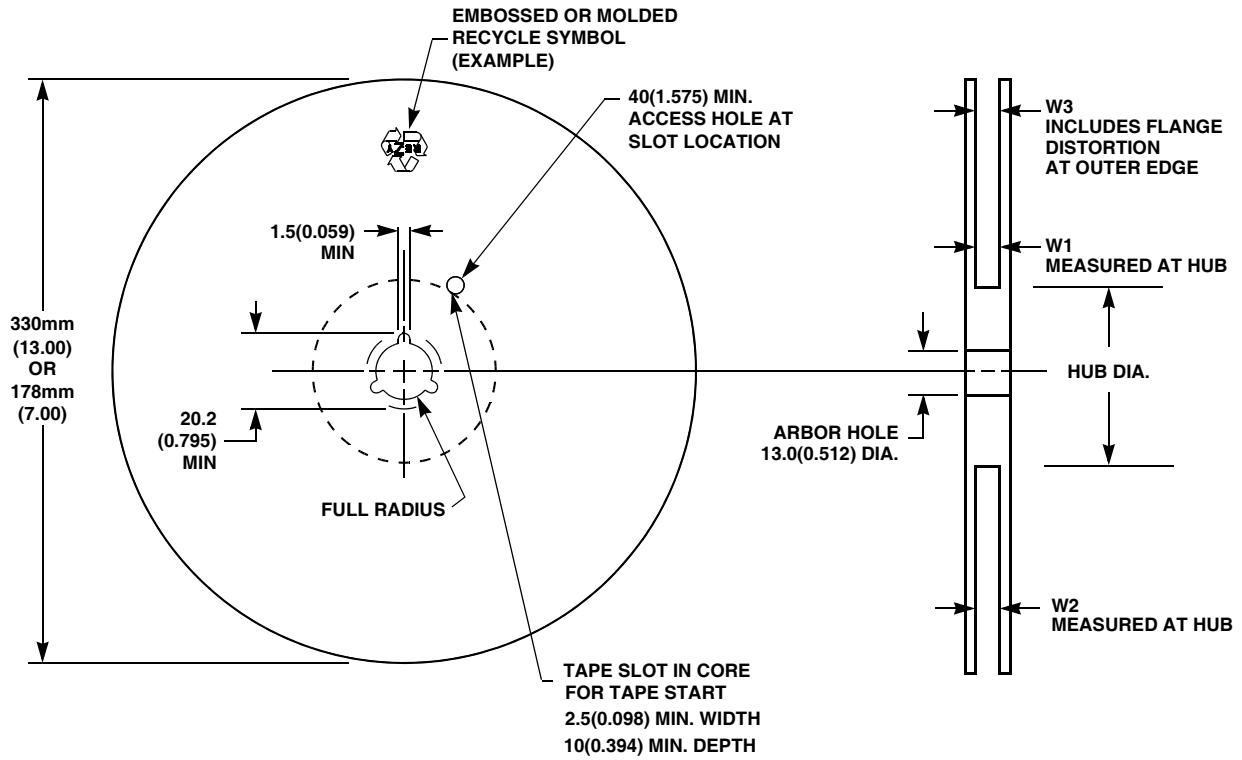

FIGURE 6. REEL DIMENSIONS

TAPE WIDTH	W1 (NOMINAL)	W2 (MAXIMUM)	W3 (MAXIMUM)
8mm (0.315)	8.4 (0.331)	14.4 (0.567)	10.9 (0.429)
12mm (0.472)	12.4 (0.488)	18.4 (0.724)	15.4 (0.606)
16mm (0.629)	16.4 (0.646)	22.4 (0.882)	19.4 (0.764)
24mm (0.945)	24.4 (0.961)	30.4 (1.197)	27.4 (1.079)
32mm (1.260)	32.4 (1.276)	38.4 (1.512)	35.4 (1.394)
44mm (1.732)	44.4 (1.748)	50.4 (1.984)	47.4 (1.866)

NOTE:

25. Dimensions are in millimeters (inches are in brackets for reference only).

Intersil Corporation reserves the right to make changes in circuit design, software and/or specifications at any time without notice. Accordingly, the reader is cautioned to verify that the Application Note or Technical Brief is current before proceeding.

For information regarding Intersil Corporation and its products, see www.intersil.com