

**HIP4080 and HIP4081 Power-up Application**

The HIP4080 and HIP4081 H-Bridge Driver ICs require external circuitry to assure reliable start-up conditions of the upper drivers. If not addressed in the application, the H-bridge power MOSFETs may be exposed to shoot-through current, possibly leading to MOSFET failure. Following the instructions below will result in reliable start-up.

**HIP4081**

The HIP4081 has four inputs, one for each output. Outputs ALO and BLO are directly controlled by input ALI and BLI. By holding ALI and BLI low during start-up no shoot-through conditions can occur. To set the latches to the upper drivers such that the driver outputs, AHO and BHO, are off, the DIS pin must be toggled from low to high after power is applied. This is accomplished with a simple resistor divider, as shown below in Figure 1. As the  $V_{DD}/V_{CC}$  supply ramps from zero up, the DIS voltage is below its input threshold of 1.7V due to the R1/R2 resistor divider. When  $V_{DD}/V_{CC}$  exceeds approximately 9V to 10V, DIS becomes greater than the input threshold and the chip disables all outputs. It is critical that ALI and BLI be held low prior to DIS reaching its threshold

level of 1.7V while  $V_{DD}/V_{CC}$  is ramping up, so that shoot through is avoided. After power is up the chip can be enabled by the ENABLE signal which pulls the DIS pin low.

**HIP4080**

The HIP4080 does not have an input protocol like the HIP4081 that keeps both lower power MOSFETs off other than through the DIS pin. IN+ and IN- are inputs to a comparator that control the bridge in such a way that only one of the lower power devices is on at a time, assuming DIS is low. However, keeping both lower MOSFETs off can be accomplished by controlling the lower turn-on delay pin, LDEL, while the chip is enabled, as shown in Figure 2. Pulling LDEL to  $V_{DD}$  will indefinitely delay the lower turn-on delays through the input comparator and will keep the lower MOSFETs off. With the lower MOSFETs off and the chip enabled, i.e. DIS = low, IN+ or IN- can be switched through a full cycle, properly setting the upper driver outputs. Once this is accomplished, LDEL is released to its normal operating point. It is critical that IN+/IN- switch a full cycle while LDEL is held high, to avoid shoot-through. This start-up procedure can be initiated by the supply voltage and/or the chip enable command by the circuit in Figure 2.

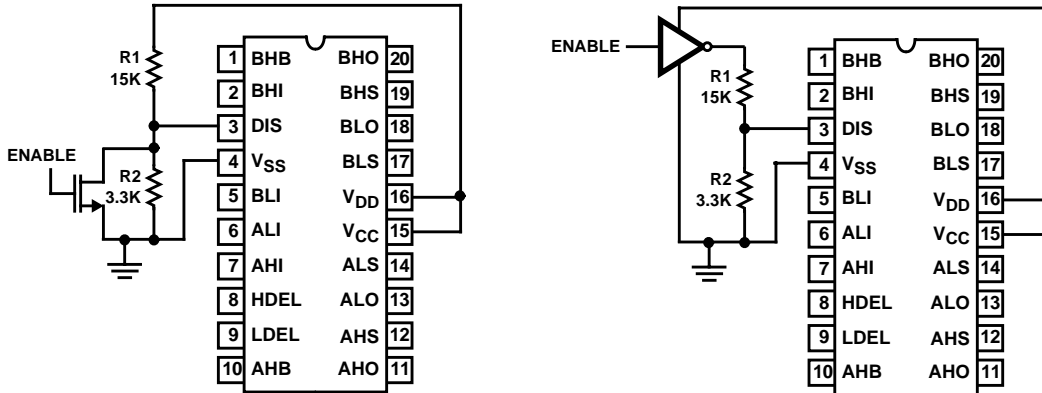

FIGURE 1.

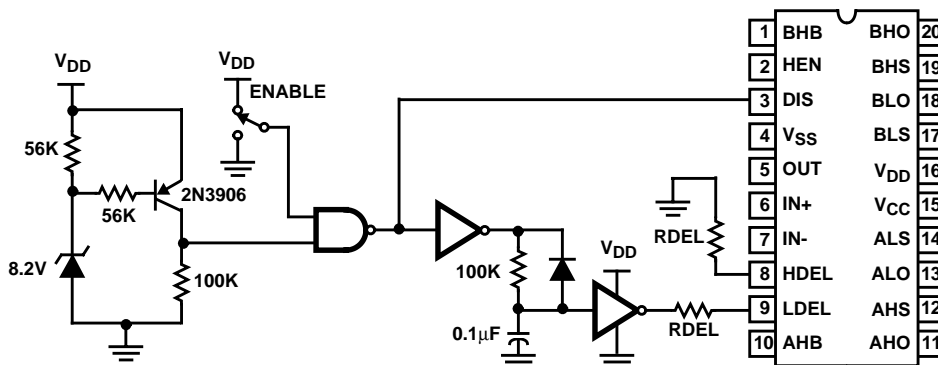
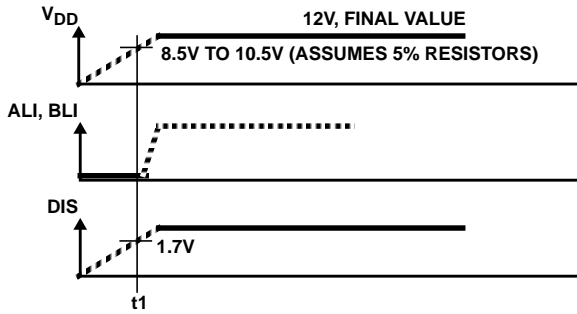

FIGURE 2.

Timing Diagrams



NOTE:

1. ALI and/or BLI may be high after t<sub>1</sub>, whereupon the ENABLE pin may also be brought high.

TIMING DIAGRAM FOR FIGURE 1.

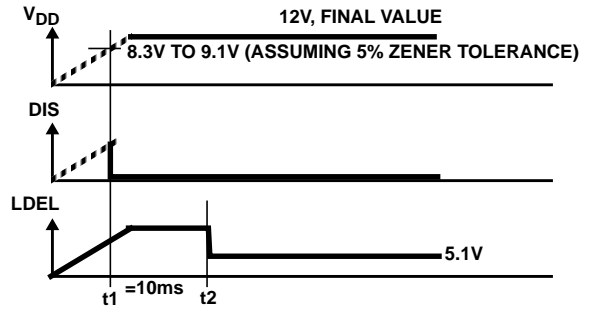

NOTE:

1. Between t<sub>1</sub> and t<sub>2</sub> the IN+ and IN- inputs must cause the OUT pin to go through one complete cycle (transition order is not important). If the ENABLE pin is low after the undervoltage circuit is satisfied, the ENABLE pin will initiate the 10ms time delay during which the IN+ and IN- pins must cycle at least once.

TIMING DIAGRAM FOR FIGURE 2.

All Intersil semiconductor products are manufactured, assembled and tested under **ISO9000** quality systems certification.

*Intersil semiconductor products are sold by description only. Intersil Corporation reserves the right to make changes in circuit design and/or specifications at any time without notice. Accordingly, the reader is cautioned to verify that data sheets are current before placing orders. Information furnished by Intersil is believed to be accurate and reliable. However, no responsibility is assumed by Intersil or its subsidiaries for its use; nor for any infringements of patents or other rights of third parties which may result from its use. No license is granted by implication or otherwise under any patent or patent rights of Intersil or its subsidiaries.*

For information regarding Intersil Corporation and its products, see web site [www.intersil.com](http://www.intersil.com)

Sales Office Headquarters

**NORTH AMERICA**

Intersil Corporation  
 P. O. Box 883, Mail Stop 53-204  
 Melbourne, FL 32902  
 TEL: (321) 724-7000  
 FAX: (321) 724-7240

**EUROPE**

Intersil SA  
 Mercure Center  
 100, Rue de la Fusee  
 1130 Brussels, Belgium  
 TEL: (32) 2.724.2111  
 FAX: (32) 2.724.22.05

**ASIA**

Intersil (Taiwan) Ltd.  
 7F-6, No. 101 Fu Hsing North Road  
 Taipei, Taiwan  
 Republic of China  
 TEL: (886) 2 2716 9310  
 FAX: (886) 2 2715 3029