

# Package Outline Drawing

## V192.17x17

192 PLASTIC BALL GRID ARRAY PACKAGE (CAVITY DOWN)

Rev 0, 07/09

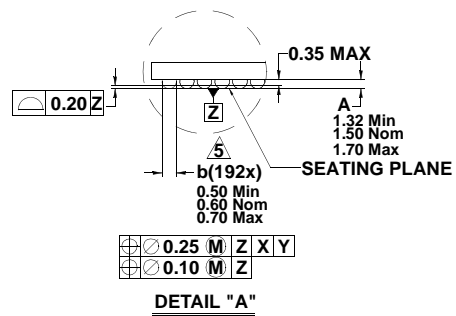
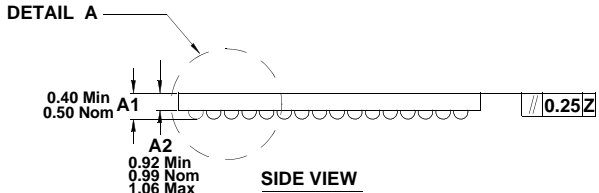
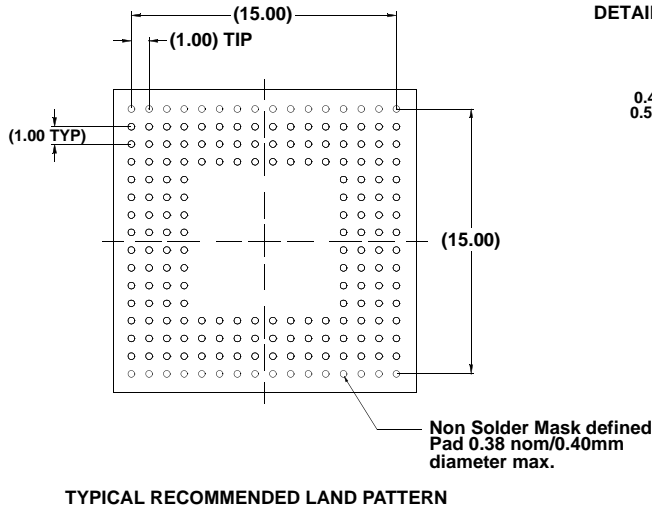
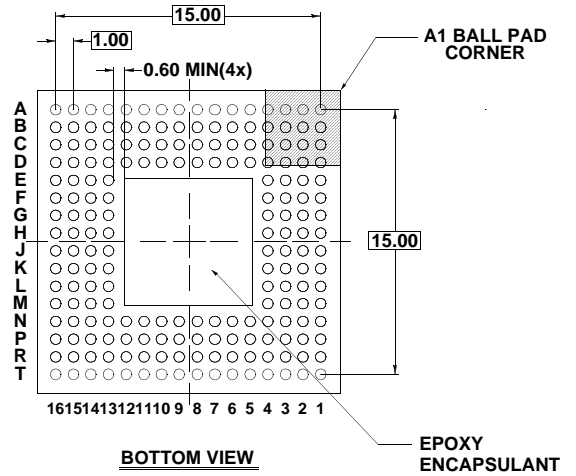
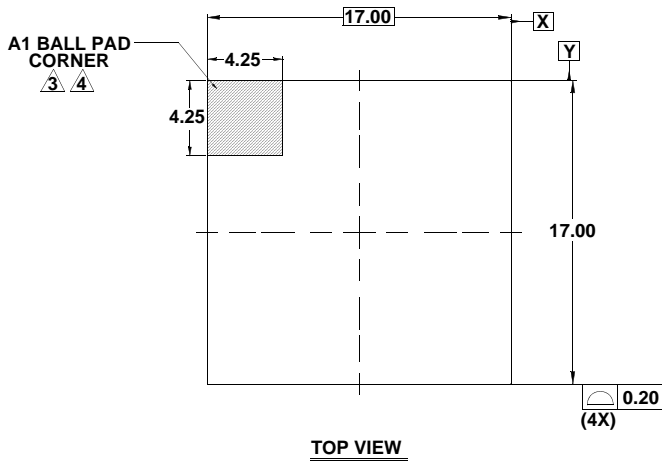

**NOTES:**

1. Dimensions are in millimeters.  
Dimensions in ( ) for Reference Only.
2. Terminal positions designation per JESD 95-1, SPP-010.
3. Corner details per stats option.
4. Pin 1 identifier can be chamfer, ink mark or metallized mark, but located within zone indicated.
5. Reflow ball diameter.
6. Compliant to JEDEC registered outline MS-034, variation AAF-1.