

Plastic Ball Grid Array Packages (BGA)

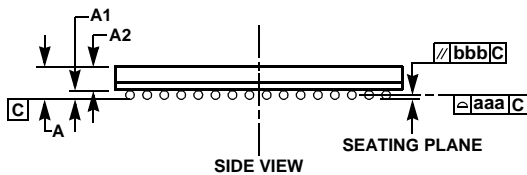
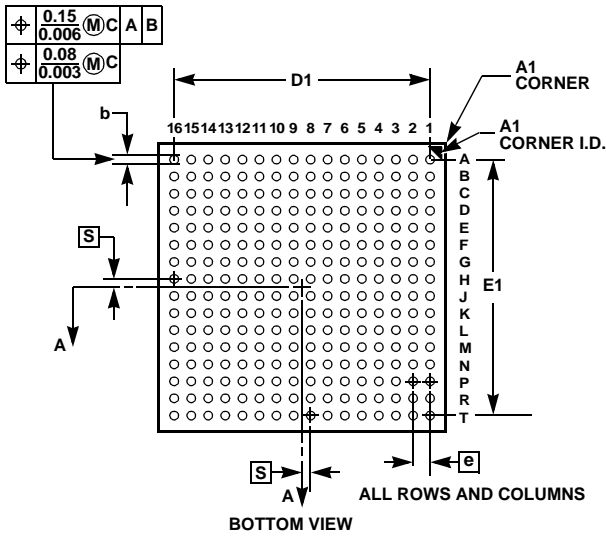
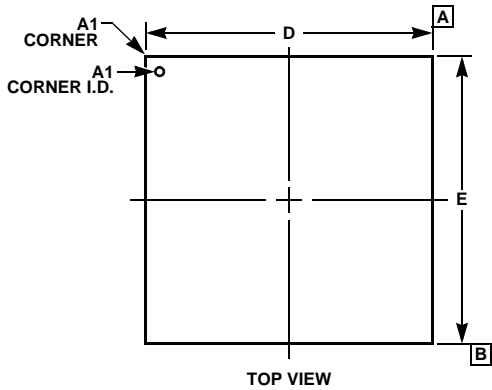

V256.17x17

256 BALL PLASTIC BALL GRID ARRAY PACKAGE

SYMBOL	INCHES		MILLIMETERS		NOTES
	MIN	MAX	MIN	MAX	
A	-	0.059	-	1.50	-
A1	0.012	0.016	0.31	0.41	-
A2	0.037	0.044	0.95	1.13	-
b	0.016	0.020	0.41	0.51	7
D/E	0.665	0.673	16.90	17.10	-
D1/E1	0.587	0.595	14.90	15.10	-
N	256		256		-
e	0.039 BSC		1.0 BSC		-
MD/ME	16 x 16		16 x 16		-
bbb	0.004		0.10		3
ααα	0.005		0.12		-

Rev. 2 01/03

NOTES:

- Controlling dimension: MILLIMETER. Converted inch dimensions are not necessarily exact.
- Dimensioning and tolerancing conform to AMSE Y14.5M-1994.
- "MD" and "ME" are the maximum ball matrix size for the "D" and "E" dimensions, respectively.
- "N" is the maximum number of balls for the specific array size.
- Primary datum C and seating plane are defined by the spherical crowns of the contact balls.
- Dimension "A" includes standoff height "A1", package body thickness and lid or cap height "A2".
- Dimension "b" is measured at the maximum ball diameter, parallel to the primary datum C.
- Pin "A1" is marked on the top and bottom sides adjacent to A1.
- "S" is measured with respect to datum's A and B and defines the position of the solder balls nearest to package centerlines. When there is an even number of balls in the outer row the value is "S" = e/2.