

Thin Plastic Quad Flatpack Exposed Pad Packages (EPTQFP)

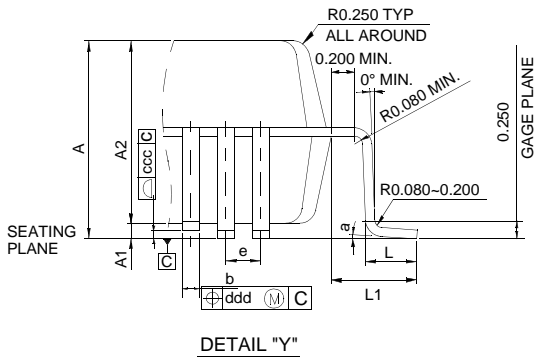
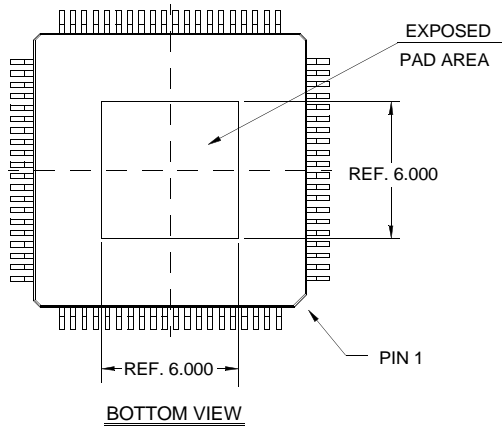
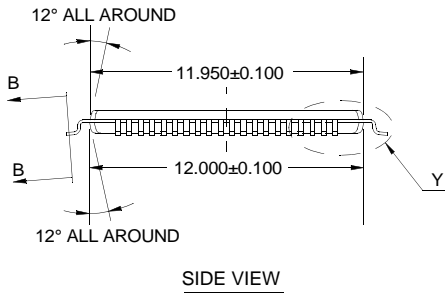
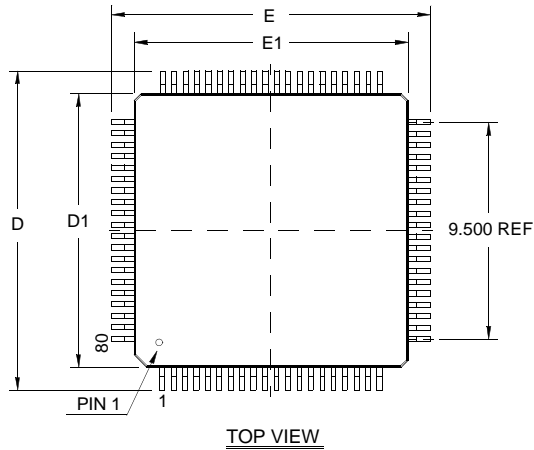

Q80.12x12

80 LEAD THIN PLASTIC QUAD FLATPACK EXPOSED PAD PACKAGE

SYMBOL	MILLIMETERS			REMARKS
	MIN	TYP	MAX	
A	-	-	1.20	Overall height
A1	0.05	0.10	0.15	Standoff
A2	0.90	1.00	1.10	Package thickness
D	13.8	14.0	14.2	Lead tip to tip
D1	11.9	12.0	12.1	Package length
E	13.8	14.0	14.2	Lead tip to tip
E1	11.9	12.0	12.1	Package width
L	0.45	0.60	0.75	Foot length
L1	1.000 REF.			Lead length
T	0.09	0.150	0.20	Lead thickness
T1	0.097	0.127	0.157	Lead base metal thickness
a	0°~7°			Foot angle
b	0.17	0.22	0.27	Lead width
b1	0.17	0.20	0.23	Lead base metal width
e	0.500 BASE			Lead pitch
ccc	-	0.080	-	Foot coplanarity
ddd	-	0.080	-	Foot position

Rev. 0 8/07

NOTES:

1. General tolerance. Distance: ± 0.1000 , Angle: $\pm 2.5^\circ$
2. Matte finish on package body surface except ejection and pin 1 marking: Ra0.8~2.0um
3. All molded body sharp corner radii unless otherwise specified: MAX. R0.200
4. Package/lead frame misalignment (X, Y): MAX. 0.127
5. Top/bottom package misalignment (X, Y): MAX. 0.127
6. Drawing does not include plastic or metal protrusion or cutting burr.
7. Compliant to JEDEC standard MS-026.

