

Optical Dual Flat No-Lead Family (ODFN)

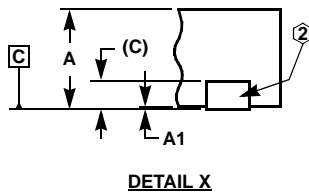
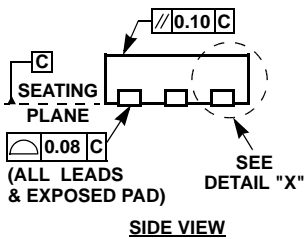
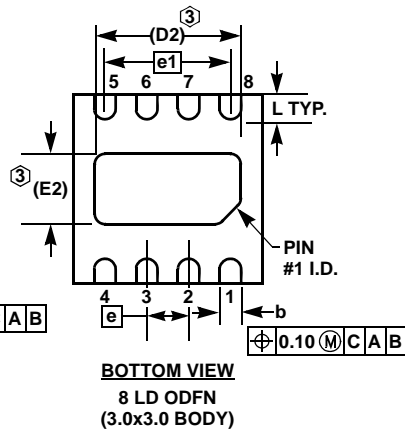
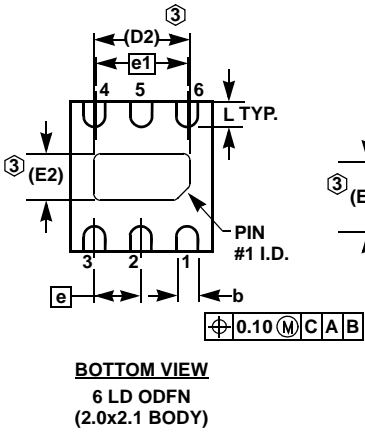
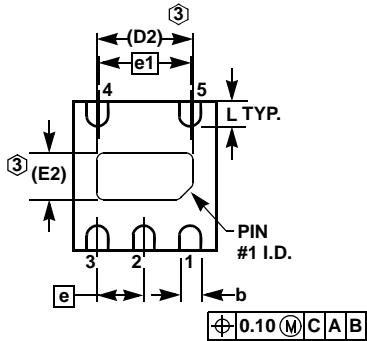
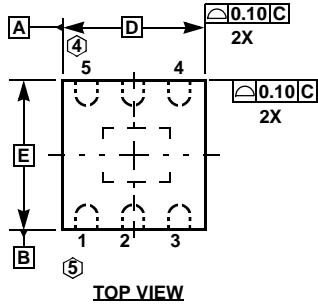

MDP0052

OPTICAL DUAL FLAT NO-LEAD FAMILY

SYMBOL	MILLIMETERS			TOLERANCE	NOTE
	ODFN5	ODFN6	ODFN8		
A	0.70	0.70	0.70	±0.05	
A1	0.02	0.02	0.02	+0.03/-0.02	
b	0.30	0.30	0.30	±0.05	
c	0.20	0.20	0.20	Reference	2
D	2.00	2.00	3.00	Basic	
D2	1.35	1.35	2.29	Reference	3
E	2.10	2.10	3.00	Basic	
E2	0.65	0.65	1.40	Reference	3
e	0.65	0.65	0.65	Basic	
e1	1.30	1.30	1.95	Basic	
L	0.35	0.35	0.40	±0.05	

Rev. 5 2/07

NOTES:

1. Dimensioning and tolerancing per ASME Y14.5M-1994.
2. Exposed lead at side of package is a non-functional feature.
3. Dimension D2 and E2 define the size of the exposed pad.
4. ODFN 5 Ld version has no center lead (shown as dashed line).