

## Introduction

This application note describes the SPICE macro-model for the HA-5137, a wide bandwidth precision op amp. The model was designed to be compatible with the well known SPICE program developed by the University of California in hope that most simulation software vendors follow this basic format and syntax. A schematic of the macro-model, the Spice net listing and various simulated performance curves are included. The macro-model schematic includes node numbers to help relate the SPICE listing to the schematic. The model is designed to emulate a typical rather than a worst case part. Most AC and DC parameters are simulated. Significant poles and zeros are included to give the most accurate AC and transient simulation with minimum complexity.

## Model Description

### Input Stage

DP and DN represent the differential input resistance. Input bias currents are created by I1 and offset current is modeled with FA. Source VN represents the input offset voltage. C1 limits slew rate. No input parasitics due to package capacitance and lead inductance are included.

### Gain Stage

G2, R2, CC, GOL, and RD simulate open loop gain. CC is the macro-model dominant pole capacitor.

### Poles and Zeros

The most significant singularities of the HA-5137 are modeled by RC networks. One pole-zero pair and four additional poles are used.

### Output Stage

EX1, D1 and D2 model output current limiting. IH and IL are the power supply currents. DPH, DPL and GPS vary the supply currents based on the opamp's output current. DL, DH, ECC and EEE provide voltage clamping on the output to simulate the typical output voltage swing. Some effects of output parasitics due to package capacitance and inductance are lumped with the poles.

### Parameters Not Modeled

To maintain a simple macro-model not all op amp parameters are modeled. Most of the parameters not modeled are listed below:

- Temperature Effects
- Differential Voltage Restrictions
- Input Voltage and Current Noise
- Common Mode Restrictions
- Tolerances for Monte Carlo Analysis
- Power Supply Range

**Spice Listing**

```

*
*COPYRIGHT (C) 1992 INTERSIL CORPORATION
*ALL RIGHTS RESERVED
*
*HA-5137 MACRO-MODEL
*REV: 2-04-92
*BY: D.W. RIEMER
*
*PINOUT      +IN -IN VCC VEE OUT
*
.SUBCKT HA5137 1 2 4 5 3
.MODEL DP D IS=1E-14 N=+6.6967E-01
.MODEL DN D IS=+8.5E-15 N=+6.6967E-01
.MODEL DV D IS=+1.1746E-14 N=.2
.MODEL D1 D IS=1E-9 N=1
.MODEL D2 D IS=1E-9 N=+1.0
.MODEL DX D IS=1E-20 N=+30.0

* INPUT STAGE
*VALUE OF SOURCE VN MODELS VIO AND
*MAY BE ADJUSTED AS DESIRED.
*
VP 1 6 0
VN 2 7 +1.0E-05
I1 8 0 +1.295E-08
FA 2 0 VN +1.857E+00
DP 6 8 DP
DN 7 8 DN
C1 8 0 +1.0792E-16 IC=-2.3157E-01
FP 9 0 VP +3.0579E+04
FN 0 9 VN +3.5975E+04
GC 0 9 8 0 +1.2372E-08
GPP 9 0 4 0 +2.2123E-08
GPN 9 0 5 0 +2.2123E-08
IRX 0 9 +2.865E-09
RT 9 0 1.0

* OUTPUT STAGE
G2 0 21 20 0 1.0
R2 21 0 +6.5577E+02
CC 21 22 +2.2E-11
GOL 22 0 21 0 +3.6187E+03
RD 22 0 +5.0809E+01
DH 22 23 DV
DL 24 22 DV
ECC 23 0 POLY 1 4 0 -2.7 1.0
EEE 24 0 POLY 1 5 0 +2.7 1.0
IH 4 0 +3.5E-03
IL 0 5 +3.5E-03
GPS 25 0 22 3 +8.5427E-02
DPH 4 25 DX
DPL 25 5 DX
D1 22 26 D1
D2 26 22 D2
EX1 26 0 POLY 2 22 0 3 0 0.0 -7.2888E-01 +1.7249
RO 22 3 +1.17059E+01
.ENDS HA5137

* POLES AND ZEROS
EP1 10 0 9 0 1.0
RP1 10 11 +2.21E+02
RZ1 11 12 +1.77E+02
CP1 12 0 1E-10
EP2 13 0 11 0 1.0
RP2 13 14 +1.592E+01
CP2 14 0 1E-10
EP3 15 0 14 0 1.0
RP3 15 16 +1.0613E+01
CP3 16 0 1E-10
EP4 17 0 16 0 1.0
RP4 17 18 +9.0971
CP4 18 0 1E-10
EP5 19 0 18 0 1.0
RP5 19 20 +7.96
CP5 20 0 1E-10
*

```

Macro-Model Schematic

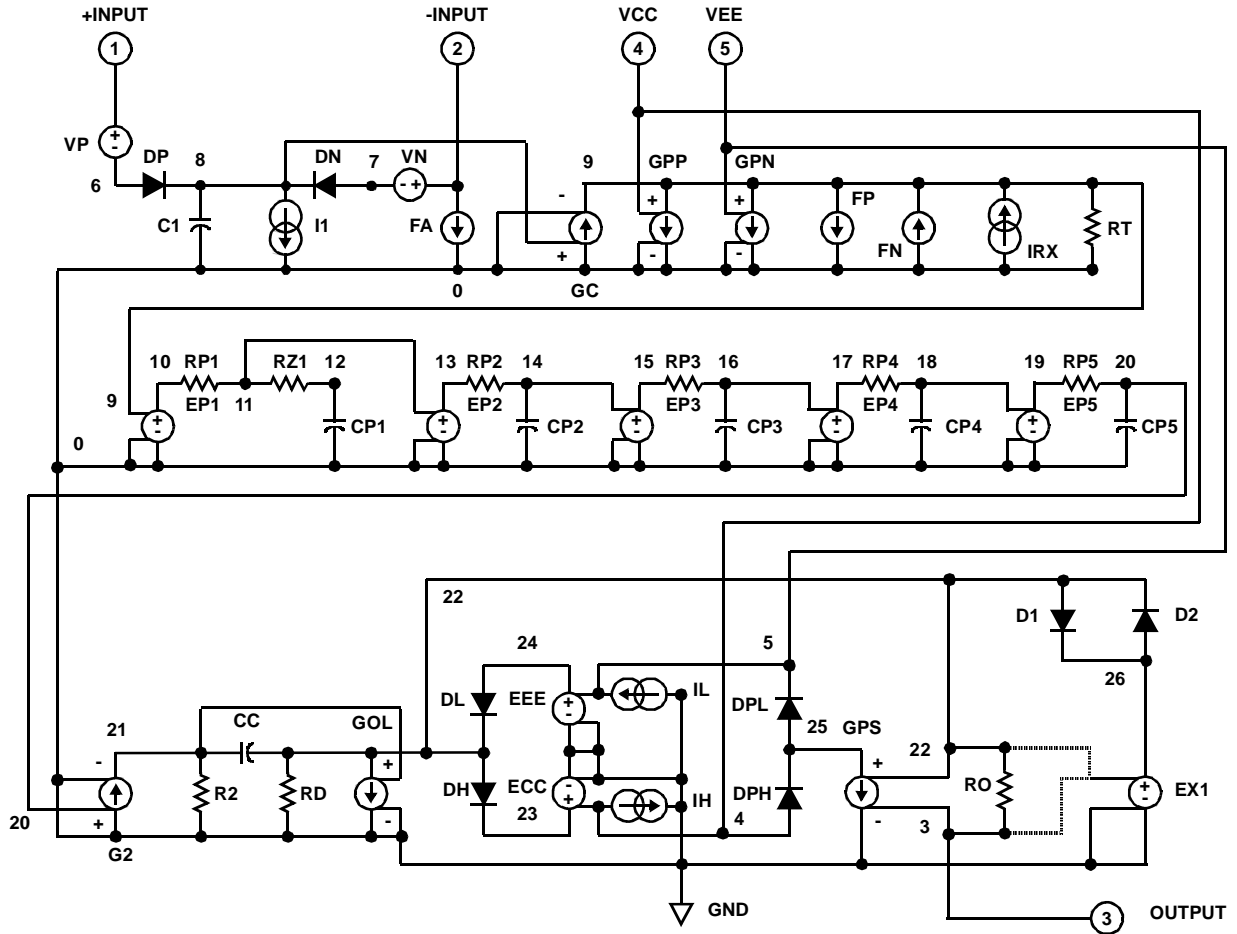

Typical Performance Curves

GAIN/PHASE RESPONSE vs FREQUENCY

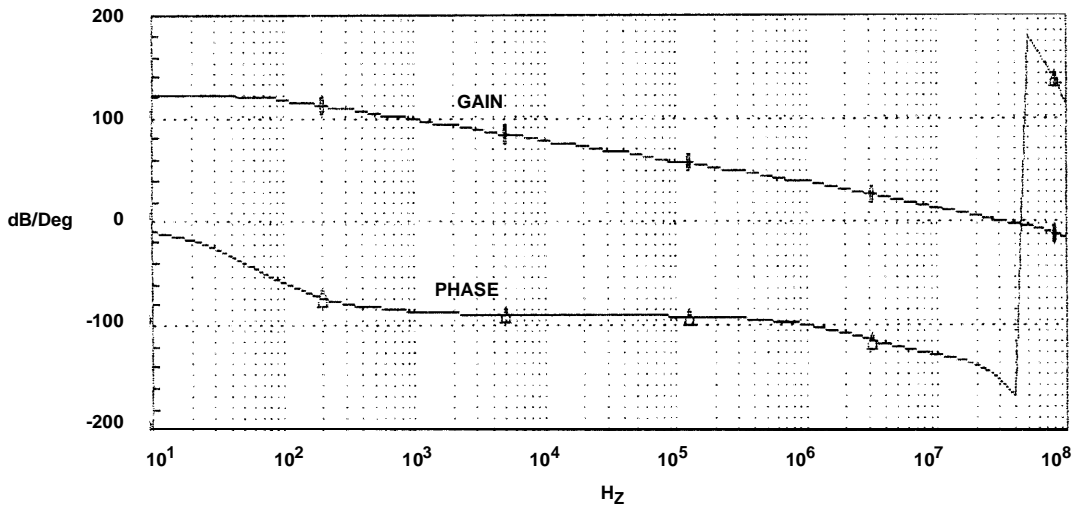

Typical Performance Curves (Continued)

SMALL SIGNAL RESPONSE

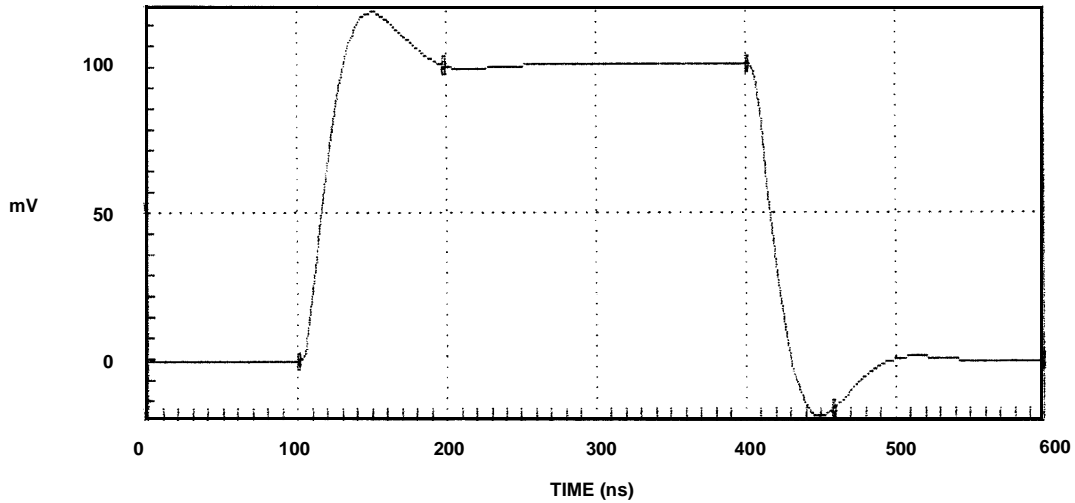

LARGE SIGNAL RESPONSE

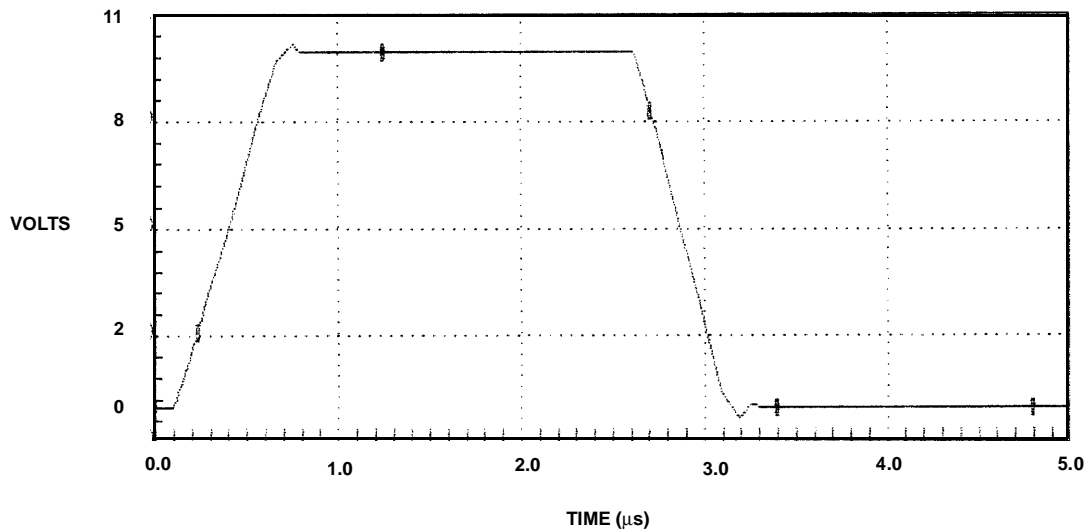

All Intersil products are manufactured, assembled and tested utilizing ISO9000 quality systems. Intersil Corporation's quality certifications can be viewed at [www.intersil.com/design/quality](http://www.intersil.com/design/quality)

*Intersil products are sold by description only. Intersil Corporation reserves the right to make changes in circuit design and/or specifications at any time without notice. Accordingly, the reader is cautioned to verify that data sheets are current before placing orders. Information furnished by Intersil is believed to be accurate and reliable. However, no responsibility is assumed by Intersil or its subsidiaries for its use; nor for any infringements of patents or other rights of third parties which may result from its use. No license is granted by implication or otherwise under any patent or patent rights of Intersil or its subsidiaries.*

For information regarding Intersil Corporation and its products, see [www.intersil.com](http://www.intersil.com)

**Sales Office Headquarters**

**NORTH AMERICA**  
Intersil Corporation  
7585 Irvine Center Drive  
Suite 100  
Irvine, CA 92618  
TEL: (949) 341-7000  
FAX: (949) 341-7123

Intersil Corporation  
2401 Palm Bay Rd.  
Palm Bay, FL 32905  
TEL: (321) 724-7000  
FAX: (321) 724-7946

**EUROPE**  
Intersil Europe Sarl  
Ave. C - F Ramuz 43  
CH-1009 Pully  
Switzerland  
TEL: +41 21 7293637  
FAX: +41 21 7293684

**ASIA**  
Intersil Corporation  
Unit 1804 18/F Guangdong Water Building  
83 Austin Road  
TST, Kowloon Hong Kong  
TEL: +852 2723 6339  
FAX: +852 2730 1433