

**NOT RECOMMENDED FOR NEW DESIGNS
NO RECOMMENDED REPLACEMENT**
contact our Technical Support Center at
1-888-INTERSIL or www.intersil.com/tsc

Low Power RTC with Battery Backed SRAM and 50/60 Cycle AC Input and Xtal Back-up

The ISL12032 device is a low power real time clock with 50/60 AC input for timing synchronization. It also has an oscillator utilizing an external crystal for timing back-up, clock/calendar registers, intelligent battery back-up switching, battery voltage monitor, brownout indicator, integrated trickle charger for super capacitor, single periodic or polled alarms, POR supervisory function, and up to 4 Event Detect with time stamp. There are 128 bytes of battery-backed user SRAM.

The oscillator uses a 50/60 cycle sine wave input, backed by an external, low-cost, 32.768kHz crystal. The real time clock tracks time with separate registers for hours, minutes, and seconds. The calendar registers contain the date, month, year, and day of the week. The calendar is accurate through year 2100, with automatic leap year correction and auto daylight savings correction.

Pinout

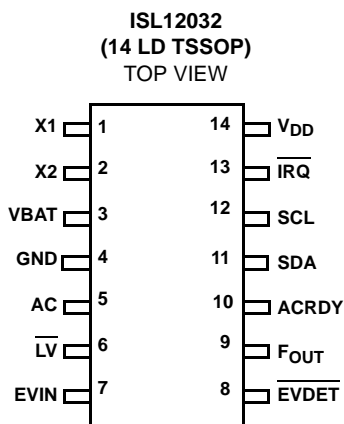

Features

- 50/60 Cycle AC as a Primary Clock Input for RTC Timing
- Redundant Crystal Clock Input Selectable by User
 - Dynamically Switch from AC Clock Input to Crystal in Case of Power Failure
- Real Time Clock/Calendar
 - Tracks Time in Hours, Minutes, Seconds and Tenths of a Second
 - Day of the Week, Day, Month, and Year
- Auto Daylight Saving Time Correction
 - Programmable Forward and Backward Dates
- Security and Event Functions
 - Event Detection with Time Stamp
 - Stores First and Last Three Event Time Stamps
- Separate F_{OUT} Pin
 - 7 Selectable Frequency Outputs
- Dual Alarms with Hardware and Register Indicators
 - Hardware Single Event or Pulse Interrupt Mode
- Automatic Backup to Battery or Super Capacitor
 - VBAT Operation Down to 1.8V
 - 1.0µA Battery Supply Current
- Two Battery Status Monitors with Selectable Levels
 - Seven Selectable Voltages for Each Level
 - 1st Level, Trip Points from 4.675V to 2.125V
 - 2nd Level, Trip Points from 4.125V to 1.875V
- V_{DD} Power Brownout Monitor
 - Six Selectable Trip Levels, from 4.675V to 2.295V
- Time Stamp during Power-to-Battery and Battery-to-Power Switchover
- Integrated Trickle Charger
 - Four Selectable Charging Rates
- 128 Bytes Battery-Backed User SRAM
- I²C Interface
 - 400kHz Data Transfer Rate
- Pb-free (RoHS compliant)

Applications

- Utility Meters
- Control Applications
- Security Related Applications
- Vending Machines
- White Goods
- Consumer Electronics

Ordering Information

PART NUMBER (Note)	PART MARKING	V _{DD} RANGE	TEMP RANGE (°C)	PACKAGE (Pb-free)	PKG DWG #
ISL12032IVZ*	12032 IVZ	2.7V to 5.5V	-40 to +85	14 Ld TSSOP	M14.173

*Add "-T" suffix for tape and reel. Please refer to TB347 for details on reel specifications.

NOTE: These Intersil Pb-free plastic packaged products employ special Pb-free material sets; molding compounds/die attach materials and 100% matte tin plate PLUS ANNEAL - e3 termination finish, which is RoHS compliant and compatible with both SnPb and Pb-free soldering operations. Intersil Pb-free products are MSL classified at Pb-free peak reflow temperatures that meet or exceed the Pb-free requirements of IPC/JEDEC J STD-020.

Block Diagram

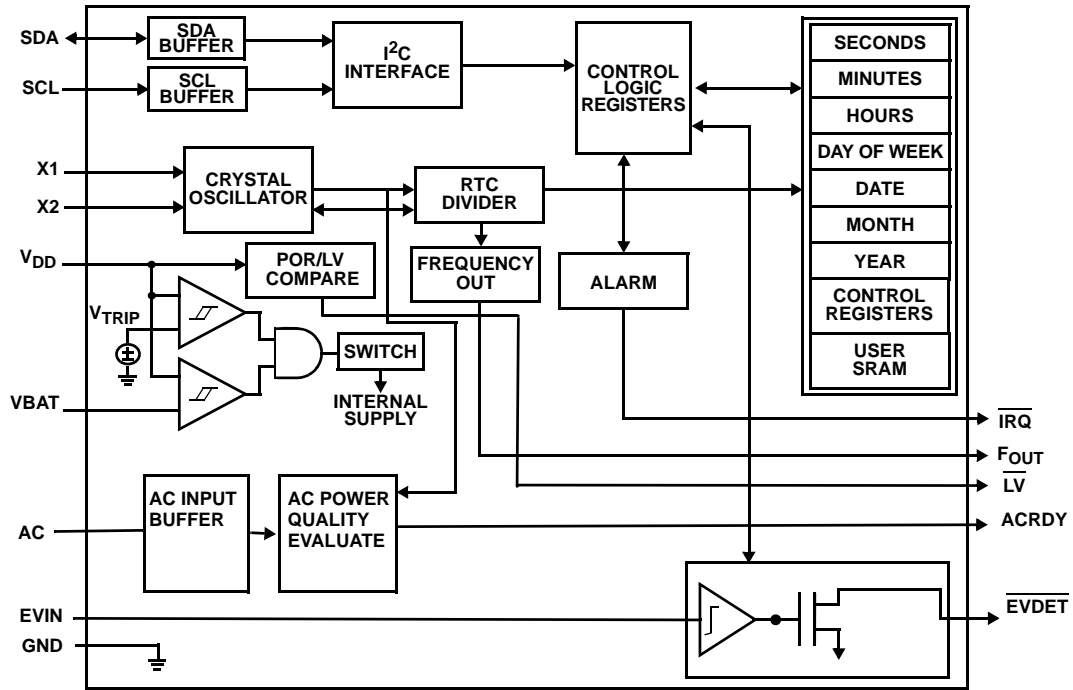

Functional Pin Descriptions

PIN NUMBER	SYMBOL	DESCRIPTION
1	X1	The input of an inverting amplifier and is intended to be connected to one pin of an external 32.768kHz quartz crystal. X1 also can be driven directly from a 32.768kHz source with no crystal connected.
2	X2	The output of an inverting amplifier and is intended to be connected to one pin of an external 32.768kHz quartz crystal. X2 should be left open when X1 is driven from an external source.
3	VBAT	Battery Voltage. This pin provides a backup supply voltage to the device. VBAT supplies power to the device in the event that the V _{DD} supply fails. This pin should be tied to ground if not used.
4	GND	Ground.
5	AC	AC Input. The AC input pin accepts either 50Hz or 60Hz AC 2.5V _{p-p} sine wave signal.
6	$\overline{\text{LV}}$	Low Voltage detection output/Brownout Alarm. Open drain active low output.
7	EVIN	Event Input - The EVIN is a logic input pin that is used to detect an externally monitored event. When a high signal is present at the EVIN pin, an "event" is detected.
8	$\overline{\text{EVDET}}$	Event Detect Output. Active when EVIN is triggered. Open Drain active low output.
9	F _{OUT}	Frequency Output. Register selectable frequency clock output. CMOS output levels.
10	ACRDY	AC Ready. Open Drain output. When High, AC input signal is qualified for timing use.
11	SDA	Serial Data. SDA is a bi-directional pin used to transfer serial data into and out of the device. It has an open drain output and may be wire OR'ed with other open drain or open collector outputs.
12	SCL	Serial Clock. The SCL input is used to clock all serial data into and out of the device.
13	$\overline{\text{IRQ}}$	Interrupt Output. Open Drain active low output. Interrupt output pin to indicate alarm is triggered.
14	V _{DD}	Power supply.

Absolute Maximum Ratings

Voltage on V_{DD}, V_{BAT}, SCL, SDA, ACRDY, AC, $\overline{\text{LV}}$, $\overline{\text{EVDET}}$, EVIN, IRQ, F_{OUT} pins (respect to ground) -0.3V to 6.0V
 Voltage on X1 and X2 pins (respect to ground) -0.3V to 2.5V
 ESD Rating
 Human Body Model (Per MIL-STD-883 Method 3014) >2kV
 Machine Model >200V

Thermal Information

Thermal Resistance (Typical, Note 1) θ_{JA} (°C/W)
 14 Ld TSSOP 120
 Storage Temperature -65°C to +150°C
 Pb-free reflow profile see link below
<http://www.intersil.com/pbfree/Pb-FreeReflow.asp>

Recommended Operating Conditions

Temperature (T_A) -40°C to +85°C
 Supply Voltage (V_{DD}) 2.7V to 5.5V
 Supply Voltage (V_{BAT}) 1.8V to 5.5V

CAUTION: Do not operate at or near the maximum ratings listed for extended periods of time. Exposure to such conditions may adversely impact product reliability and result in failures not covered by warranty.

NOTE:

1. θ_{JA} is measured with the component mounted on a high effective thermal conductivity test board in free air. See Tech Brief TB379 for details.

DC Operating Characteristics Specifications apply for: V_{DD} = 2.7V to 5.5V, T_A = -40°C to +85°C, unless otherwise stated.

SYMBOL	PARAMETER	CONDITIONS	MIN (Note 10)	TYP (Note 4)	MAX (Note 10)	UNITS	NOTES
V _{DD}	Main Power Supply		2.7		5.5	V	
V _{BAT}	Battery Supply Voltage		1.8		5.5	V	
I _{DD1}	Supply Current	V _{DD} = 5V, SCL, SDA = V _{DD}		27	60	μA	3
		V _{DD} = 3V, SCL, SDA = V _{DD}		16	45	μA	3
I _{DD2}	Supply Current (I ² C communications active)	V _{DD} = 5V		43	75	μA	2, 5
I _{DD3}	Supply Current for Timekeeping at AC Input	V _{DD} = 5.5V at T _A =+25°C, F _{OUT} disabled		9.0	18.0	μA	2, 3
I _{BAT}	Battery Supply Current	V _{BAT} = 5.5V at T _A =+25°C		1.0	1.8	μA	2, 8
		V _{BAT} = 2.7V		0.8	1.2		2, 8
		V _{BAT} = 1.8V		0.7	1.0	μA	2, 8
I _{BAT_LKG}	Battery Input Leakage	V _{DD} = 5.5V, V _{BAT} = 1.8V TRKEN = 0			100	nA	
I _{LI}	Input Leakage Current on SCL				1	μA	
I _{LO}	I/O Leakage Current on SDA				1	μA	
V _{BAT_M}	Battery Level Monitor Threshold	V _{DD} = 5.5V, V _{BAT} = 1.8V	-150		+150	mV	
V _{PBM}	Brownout Level Monitor Threshold		-150		+150	mV	
V _{TRIP}	V _{BAT} Mode Threshold		2.0	2.2	2.4	V	
V _{TRIPHYS}	V _{TRIP} Hysteresis			30		mV	
V _{BATHYS}	V _{BAT} Hysteresis			50		mV	
R _{TRK}	Trickle Charge Resistance	V _{DD} = 5.5V, V _{BAT} = 3.0V, TRKR01 = 0, TRKR00 = 0		1300		Ω	
		V _{DD} = 5.5V, V _{BAT} = 3.0V, TRKR01 = 0, TRKR00 = 1		2200		Ω	
		V _{DD} = 5.5V, V _{BAT} = 3.0V, TRKR01 = 1, TRKR00 = 0		3600		Ω	
		V _{DD} = 5.5V, V _{BAT} = 3.0V, TRKR01 = 1, TRKR00 = 1		7800		Ω	
V _{TRKTERM}	V _{BAT} Charging Termination Point			V _{DD} - 50mV		V	
V _{TRKHYS}	Trickle Charge ON-OFF Hysteresis			50		mV	

DC Operating Characteristics Specifications apply for: $V_{DD} = 2.7V$ to $5.5V$, $T_A = -40^{\circ}C$ to $+85^{\circ}C$, unless otherwise stated. (Continued)

SYMBOL	PARAMETER	CONDITIONS	MIN (Note 10)	TYP (Note 4)	MAX (Note 10)	UNITS	NOTES
IRQ/ACRDY/LV/EVDET (OPEN DRAIN OUTPUTS)							
V_{OL}	Output Low Voltage	$V_{DD} = 5V, I_{OL} = 3mA$			0.4	V	
		$V_{DD} = 2.7V, I_{OL} = 1mA$			0.4	V	
F_{OUT} (CMOS OUTPUT)							
V_{OL}	Output Low Voltage	$I_{OH} = 1mA$			$0.3 \times V_{DD}$	V	
V_{OH}	Output High Voltage		$0.7 \times V_{DD}$			V	
EVIN							
I_{EVPU}	EVIN Pull-up Current	$V_{DD} = 5.5V, V_{BAT} = 3.0V$	1.0	3.0	8.0	μA	
		$V_{DD} = 0V, V_{BAT} = 1.8V$	100		600	nA	
V_{IL}	Input Low Voltage				$0.3 \times V_{DD}$	V	
V_{IH}	Input High Voltage		$0.7 \times V_{DD}$			V	
I_{EVPD}	EVIN Disabled Pull-down Current	$V_{DD} = 5.5V$		200		nA	

Power-Down Timing Specifications apply for: $V_{DD} = 2.7V$ to $5.5V$, $T_A = -40^{\circ}C$ to $+85^{\circ}C$, unless otherwise stated.

SYMBOL	PARAMETER	CONDITIONS	MIN (Note 10)	TYP (Note 4)	MAX (Note 10)	UNITS	NOTES
$V_{DD\ SR-}$	V_{DD} Negative Slew Rate				10	V/ms	6

I²C Interface Specifications Specifications apply for: $V_{DD} = 2.7V$ to $5.5V$, $T_A = -40^{\circ}C$ to $+85^{\circ}C$, unless otherwise stated.

SYMBOL	PARAMETER	TEST CONDITIONS	MIN (Note 10)	TYP (Note 4)	MAX (Note 10)	UNITS	NOTES
V_{IL}	SDA and SCL Input Buffer LOW Voltage		-0.3		$0.3 \times V_{DD}$	V	
V_{IH}	SDA and SCL Input Buffer HIGH Voltage		$0.7 \times V_{DD}$		$V_{DD} + 0.3$	V	
Hysteresis	SDA and SCL Input Buffer Hysteresis		$0.05 \times V_{DD}$			V	
V_{OL}	SDA Output Buffer LOW Voltage, Sinking 3mA	$V_{DD} = 5V, I_{OL} = 3mA$			0.4	V	
C_{PIN}	SDA and SCL Pin Capacitance	$T_A = +25^{\circ}C, f = 1MHz,$ $V_{DD} = 5V, V_{IN} = 0V,$ $V_{OUT} = 0V$		10		pF	
f_{SCL}	SCL Frequency				400	kHz	
t_{IN}	Pulse Width Suppression Time at SDA and SCL Inputs	Any pulse narrower than the max spec is suppressed.			50	ns	
t_{AA}	SCL Falling Edge to SDA Output Data Valid	SCL falling edge crossing 30% of V_{DD} , until SDA exits the 30% to 70% of V_{DD} window.			900	ns	
t_{BUF}	Time the Bus Must be Free Before the Start of a New Transmission	SDA crossing 70% of V_{DD} during a STOP condition, to SDA crossing 70% of V_{DD} during the following START condition.	1300			ns	
t_{LOW}	Clock LOW Time	Measured at the 30% of V_{DD} crossing.	1300			ns	

I²C Interface Specifications Specifications apply for: V_{DD} = 2.7V to 5.5V, T_A = -40°C to +85°C, unless otherwise stated.
(Continued)

SYMBOL	PARAMETER	TEST CONDITIONS	MIN (Note 10)	TYP (Note 4)	MAX (Note 10)	UNITS	NOTES
t _{HIGH}	Clock HIGH Time	Measured at the 70% of V _{DD} crossing.	600			ns	
t _{SU:STA}	START Condition Setup Time	SCL rising edge to SDA falling edge. Both crossing 70% of V _{DD} .	600			ns	
t _{HD:STA}	START Condition Hold Time	From SDA falling edge crossing 30% of V _{DD} to SCL falling edge crossing 70% of V _{DD} .	600			ns	
t _{SU:DAT}	Input Data Setup Time	From SDA exiting the 30% to 70% of V _{DD} window, to SCL rising edge crossing 30% of V _{DD} .	100			ns	
t _{HD:DAT}	Input Data Hold Time	From SCL falling edge crossing 30% of V _{DD} to SDA entering the 30% to 70% of V _{DD} window.	0		900	ns	
t _{SU:STO}	STOP Condition Setup Time	From SCL rising edge crossing 70% of V _{DD} , to SDA rising edge crossing 30% of V _{DD} .	600			ns	
t _{HD:STO}	STOP Condition Hold Time	From SDA rising edge to SCL falling edge. Both crossing 70% of V _{DD} .	600			ns	
t _{DH}	Output Data Hold Time	From SCL falling edge crossing 30% of V _{DD} , until SDA enters the 30% to 70% of V _{DD} window.	0			ns	
t _R	SDA and SCL Rise Time	From 30% to 70% of V _{DD} .	20 + 0.1 x C _b		300	ns	7, 9
t _F	SDA and SCL Fall Time	From 70% to 30% of V _{DD} .	20 + 0.1 x C _b		300	ns	7, 9
C _b	Capacitive loading of SDA or SCL	Total on-chip and off-chip	10		400	pF	7, 9
R _{PU}	SDA and SCL Bus Pull-up Resistor Off-chip	Maximum is determined by t _R and t _F . For C _b = 400pF, max is about 2kΩ. For C _b = 40pF, max is about 15kΩ	1			kΩ	7, 9

NOTES:

1. \overline{IRQ} and F_{OUT} Inactive.
2. V_{DD} > V_{BAT} + V_{BATHYS}
3. Specified at T_A = +25°C.
4. F_{SCL} = 400kHz.
5. In order to ensure proper timekeeping, the V_{DD SR} specification must be followed.
6. Parameter is not 100% tested.
7. V_{DD} = 0V. I_{BAT} increases at V_{DD} voltages between 0.5V and 1.5V.
8. These are I²C specific parameters and are not tested, however, they are used to set conditions for testing devices to validate specification.
9. Parts are 100% tested at +25°C. Temperature limits established by characterization and are not production tested.

SDA vs SCL Timing

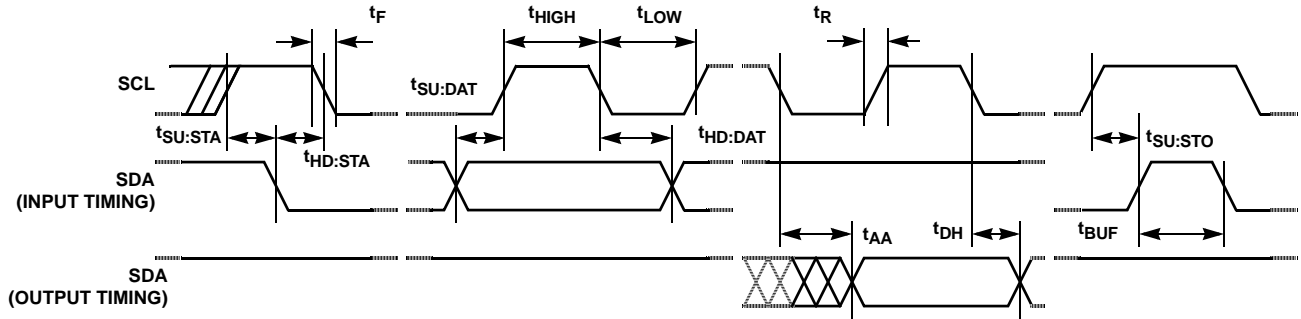

Symbol Table

WAVEFORM	INPUTS	OUTPUTS
	Must be steady	Will be steady
	May change from LOW to HIGH	Will change from LOW to HIGH
	May change from HIGH to LOW	Will change from HIGH to LOW
	Don't Care: Changes Allowed	Changing: State Not Known
	N/A	Center Line is High Impedance

EQUIVALENT AC OUTPUT LOAD CIRCUIT FOR $V_{DD} = 5V$

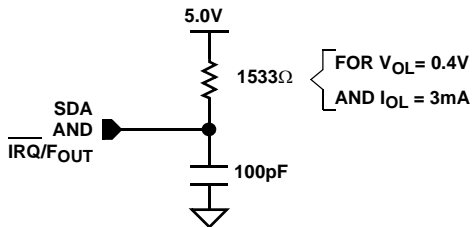

FIGURE 1. STANDARD OUTPUT LOAD FOR TESTING THE DEVICE WITH $V_{DD} = 5.0V$

General Description

The ISL12032 device is a low power real time clock with 50/60 AC input for timing synchronization. It also has an oscillator utilizing an external crystal for timing back-up, clock/calendar registers, intelligent battery back-up switching, battery voltage monitor, brownout indicator, integrated trickle charger for super capacitor, single periodic or polled alarms, POR supervisory function, and up to 4 Event Detect with time stamp. There are 128 bytes of battery-backed user SRAM.

The oscillator uses a 50/60 cycle sine wave input, backed by an external, low-cost, 32.768kHz crystal. The real time clock tracks time with separate registers for hours, minutes, and seconds. The calendar registers contain the date, month, year, and day of the week. The calendar is accurate through year 2100, with automatic leap year correction and auto daylight savings correction.

The ISL12032's alarm can be set to any clock/calendar value for a match. Each alarm's status is available by checking the Status Register. The device also can be configured to provide a hardware interrupt via the $\overline{\text{IRQ}}$ pin. There is a repeat mode for the alarms allowing a periodic interrupt every minute, every hour, every day, etc.

The device also offers a backup power input pin. This VBAT pin allows the device to be backed up by battery or Super Capacitor with automatic switchover from V_{DD} to VBAT. The ISL12032 devices are specified for $V_{DD} = 2.7V$ to 5.5V and the clock/calendar portion of the device remains fully operational in battery backup mode down to 1.8V (Standby Mode). The VBAT level is monitored and warnings are reported against preselected levels. The first report is registered when the VBAT level falls below 85% of nominal level, the second level is set for 75% of nominal level. Battery levels are stored in the PWRBAT registers.

The ISL12032 offers a "Brownout" alarm once the V_{DD} falls below a pre-selected trip level. In the ISL12032, this allows the system microcontroller to save vital information to memory before complete power loss. There are six V_{DD} trip levels for the brownout alarm.

The event detection function accepts a normally low logic input, and when triggered will store the time/date information for the event. The first event is stored in the memory until reset; subsequent events are stored on-chip memory and the last 3 events are retained and accessible by performing an indexed register read.

Pin Descriptions

X1, X2

The X1 and X2 pins are the input and output, respectively, of an inverting amplifier. An external 32.768kHz quartz crystal is used with the device to supply a backup timebase for the real time clock if there is no AC input. The device also can be driven directly from a 32.768kHz source at pin X1, in which case, pin X2 should be left unconnected. No external load capacitors are needed for the X1 and X2 pins.

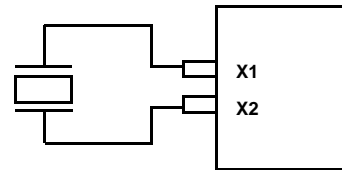

FIGURE 2. RECOMMENDED CRYSTAL CONNECTION

VBAT (Battery Input)

This input provides a backup supply voltage to the device. VBAT supplies power to the device in the event that the V_{DD} supply fails. This pin can be connected to a battery, a Super Capacitor or tied to ground if not used.

AC (AC Input)

The AC input is the main clock input for the real time clock. It can be either 50Hz or 60Hz, sine wave. The preferred amplitude is $2.5V_{P-P}$, although amplitudes $>0.25V_{DD}$ are acceptable. An AC coupled (series capacitor) sine wave clock waveform is desired as the AC clock input provides DC biasing.

$\overline{\text{LV}}$ (Low Voltage)

This pin indicates the V_{DD} supply is below the programmed level. This signal notifies a host processor that the main supply is low and requests action. It is an open drain active LOW output.

EVIN (Event Input)

The EVIN pin input detects an externally monitored event. When a HIGH signal is present at the EVIN pin, an "event" is detected. This input may be used for various monitoring functions, such as the opening of a detection switch on a chassis or door. The event detection circuit can be user enabled or disabled (see EVIN bit) and provides the option to be operational in battery backup modes (see EVATB bit). When the event detection is disabled, the EVIN pin is gated OFF. See "Functional Pin Descriptions" on page 3 for more details.

$\overline{\text{EVDET}}$ (Event Detect Output)

The $\overline{\text{EVDET}}$ is an open drain output, which will go low when an event is detected at the EVIN pin. If the event detection function is enabled, the $\overline{\text{EVDET}}$ output will go LOW and stay there until the EVT bit is cleared.

IRQ (Interrupt Output)

This pin provides an interrupt signal output. This signal notifies a host processor that an alarm has occurred and requests action. It is an open drain active LOW output.

FOUT (Frequency Output)

This pin outputs a clock signal, which is related to the crystal frequency. The frequency output is user selectable and enabled via the I²C bus. The options include seven different frequencies or disable. It is a CMOS output.

Serial Clock (SCL)

The SCL input is used to clock all serial data into and out of the device. The input buffer on this pin is always active (not gated). It is disabled when the backup power supply on the VBAT pin is activated to minimize power consumption.

Serial Data (SDA)

SDA is a bi-directional pin used to transfer data into and out of the device. It has an open drain output and may be OR'ed with other open drain or open collector outputs. The input buffer is always active (not gated) in normal mode.

An open drain output requires the use of a pull-up resistor. The output circuitry controls the fall time of the output signal with the use of a slope controlled pull-down. The circuit is designed for 400kHz I²C interface speeds. It is disabled when the backup power supply on the VBAT pin is activated.

V_{DD}, GND

Chip power supply and ground pins. The device will operate with a power supply from V_{DD} = 2.7V to 5.5VDC. A 0.1μF capacitor is recommended on the V_{DD} pin to ground.

Functional Description**Power Control Operation**

The power control circuit accepts a V_{DD} and a VBAT input. Many types of batteries can be used with Intersil RTC products. For example, 3.0V or 3.6V Lithium batteries are appropriate, and battery sizes are available that can power the ISL12032 for up to 10 years. Another option is to use a Super Capacitor for applications where V_{DD} is interrupted for up to a month. See the "Application Section" on page 24 for more information.

Normal Mode (V_{DD}) to Battery Backup Mode (VBAT)

To transition from the V_{DD} to VBAT mode, both of the following conditions must be met:

Condition 1:

$V_{DD} < V_{BAT} - V_{BATHYS}$
where $V_{BATHYS} \approx 50\text{mV}$

Condition 2:

$V_{DD} < V_{TRIP}$
where $V_{TRIP} \approx 2.2\text{V}$

Battery Backup Mode (VBAT) to Normal Mode (V_{DD})

The ISL12032 device will switch from the VBAT to V_{DD} mode when one of the following conditions occurs:

Condition 1:

$V_{DD} > V_{BAT} + V_{BATHYS}$
where $V_{BATHYS} \approx 50\text{mV}$

Condition 2:

$V_{DD} > V_{TRIP} + V_{TRIPHYS}$
where $V_{TRIPHYS} \approx 30\text{mV}$

These power control situations are illustrated in Figures 3 and Figure 4.

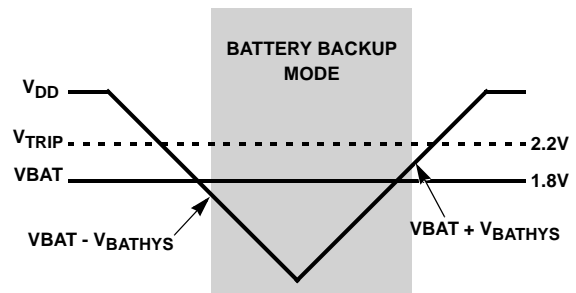

FIGURE 3. BATTERY SWITCHOVER WHEN $V_{BAT} < V_{TRIP}$

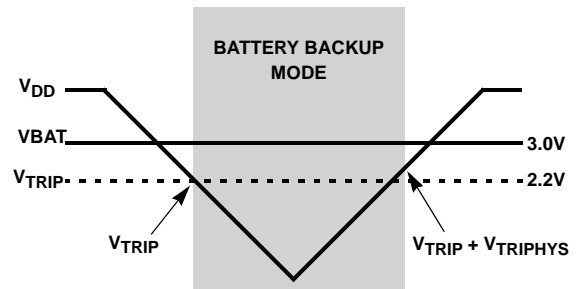

FIGURE 4. BATTERY SWITCHOVER WHEN $V_{BAT} > V_{TRIP}$

The I²C bus is normally deactivated in battery backup mode to reduce power consumption, but can be enabled by setting the I²CBAT bit. All the other inputs and outputs of the ISL12032 are active during battery backup mode unless disabled via the control register.

Power Failure Detection

The ISL12032 provides a Real Time Clock Failure Bit (RTCF) to detect total power failure. It allows users to determine if the device has powered up after having lost all power to the device (both V_{DD} and VBAT very near 0.0VDC). Note that in cases where the VBAT input is at 0.0V and the V_{DD} input dips to <1.8V, then recovers to normal level, the SRAM registers may not retain their values (corrupted bits or bytes may result).

Brownout Detection

The ISL12032 monitors the V_{DD} level continuously and provides a warning if the V_{DD} level drops below prescribed levels. There are six levels that can be selected for the trip level. These values are 85% below popular V_{DD} levels. The LVDD bit in the SRDC register will be set to “1” when Brownout is detected. Note that the I²C serial bus remains active until the Battery V_{TRIP} level is reached.

Battery Level Monitor

The ISL12032 has a built in warning feature once the VBAT battery level drops first to 85% and then to 75% of the battery's nominal VBAT level. When the battery voltage falls to between 85% and 75%, the LBAT85 bit is set in the SRDC register. When the level drops below 75%, both LBAT85 and LBAT75 bits are set in the SRDC register. The trip levels for the 85% and 75% levels are set using the PWRBAT register.

The Battery Timestamp Function permits recovering the time/date when V_{DD} power loss occurred. Once the V_{DD} is low enough to enable switchover to the battery, the RTC time/date are written into the TSV2B section. If there are multiple power-down cycles before reading these registers, the first values stored in these registers will be retained and ensuing events will be ignored. These registers will hold the original power-down value until they are cleared by writing “00h” to each register or setting the CLRTS bit to “1”.

The V_{DD} Timestamp Function permits recovering the time/date when V_{DD} recovery occurred. Once the V_{DD} is high enough to enable switchover to V_{DD} , the RTC time/date are written into the TSB2V register. If there are multiple power-down cycles before reading these registers, the most recent event is retained in these registers and the previous events will be ignored. These registers will hold the original power-down value until they are cleared by writing “00h” to each register.

Real Time Clock Operation

The Real Time Clock (RTC) maintains an accurate internal representation of tenths of a second, second, minute, hour, day of week, date, month, and year. The RTC also has leap-year correction. The clock also corrects for months having fewer than 31 days and has a bit that controls 24 hour or AM/PM format. When the ISL12032 powers up after the loss of both V_{DD} and VBAT, the clock will not begin incrementing until at least one byte is written to the clock register.

Alarm Operation

The alarm mode is enabled via the MSB bit. Single event or interrupt alarm mode is selected via the IM bit. The standard alarm allows for alarms of time, date, day of the week, month, and year. When a time alarm occurs in single event mode, the \overline{IRQ} pin will be pulled low and the corresponding alarm status bit (ALM0 or ALM1) will be set to “1”. The status bits can be written with a “0” to clear, or if the ARST

bit is set, a single read of the SRDC status register will clear them.

The pulsed interrupt mode (setting the IM bit to “1”) activates a repetitive or recurring alarm. Hence, once the alarm is set, the device will continue to output a pulse for each occurring match of the alarm and present time. The Alarm pulse will occur as often as every minute (if only the nth second is set) or as infrequently as once a year (if at least the nth month is set). During pulsed interrupt mode, the \overline{IRQ} pin will be pulled LOW for 250ms and the alarm status bit (ALM0 or ALM1) will be set to “1”.

The alarm function is not available during battery backup mode.

Frequency Output Mode

The ISL12032 has the option to provide a clock output signal using the F_{OUT} CMOS output pin. The frequency output mode is set by using the FO bits to select 7 possible output frequency values from 1.0Hz to 32.768kHz, and disable. The frequency output can be enabled/disabled during battery backup mode by setting the FOBATB bit to “0”. When the AC input is qualified (within the parameters of AC qualification) then the Frequency Output for values 50/60Hz and below are derived from the AC input clock. Higher frequency F_{OUT} values are derived from the crystal. If the AC clock input is not qualified, then all F_{OUT} values are derived from the crystal.

General Purpose User SRAM

The ISL12032 provides 128 bytes of user SRAM. The SRAM will continue to operate in battery backup mode. However, it should be noted that the I²C bus is disabled in battery backup mode unless enabled by the I²CBAT bit.

I²C Serial Interface

The ISL12032 has an I²C serial bus interface that provides access to the control and status registers and the user SRAM. The I²C serial interface is compatible with other industry I²C serial bus protocols using a bi-directional data signal (SDA) and a clock signal (SCL).

The I²C bus normally operates down to the V_{DD} trip point set in the PWRVDD register. It can also operate in battery backup mode by setting the I2CBAT bit to “1”, in which case operation will be down to VBAT = 1.8V.

Register Descriptions

The battery-backed registers are accessible following an I²C slave byte of “1101 111x” and reads or writes to addresses [00h:47h]. The defined addresses and default values are described in the Table 1. The battery backed general purpose SRAM has a different slave address (1010 111x), so it is not possible to read/write that section of memory while accessing the registers.

REGISTER ACCESS

The contents of the registers can be modified by performing a byte or a page write operation directly to any register address.

The registers are divided into 10 sections. They are:

1. Real Time Clock (8 bytes): Address 00h to 07h.
2. Status (2 bytes): Address 08h to 09h.
3. Counter (2 bytes): Address Ah to Bh.
4. Control (9 bytes): 0Ch to 14h.
5. Day Light Saving Time (8 bytes): 15h to 1Ch
6. Alarm 0/1 (12 bytes): 1Dh to 28h
7. Time Stamp for Battery Status (5 bytes): Address 29h to 2Dh.
8. Time Stamp for VDD Status (5 bytes): Address 2Eh to 32h.
9. Time Stamp for Event Status (5 bytes): 33h to 37h.

Write capability is allowable into the RTC registers (00h to 07h) only when the WRTC bit (bit 6 of address 0Ch) is set to "1". Other sections do not need to have the WRTC bit set for write access. A read or write can begin at any address within the section. A write to sections 2 through 9 can be continuous. A write can overlap two or more sections as well.

A register can be read by performing a random read at any address at any time. This returns the contents of that register location. Additional registers are read by performing a sequential read. For the RTC and Alarm registers, the read instruction latches all clock registers into a buffer, so an update of the clock does not change the time being read. At the end of a read, the master supplies a stop condition to end the operation and free the bus. After a read, the address remains at the previous address +1 so the user can execute a current address read and continue reading the next register.

It is only necessary to set the WRTC bit prior to writing into the RTC registers. All other registers are completely accessible without setting the WRTC bit.

TABLE 1. REGISTER MEMORY MAP (X indicates writes to these bits have no effect on the device)

ADDR	SECTION	REG NAME	BIT								RANGE	DEFAULT	
			7	6	5	4	3	2	1	0			
00h	RTC	SC	0	SC22	SC21	SC20	SC13	SC12	SC11	SC10	0 to 59	00h	
01h		MN	0	MN22	MN21	MN20	MN13	MN12	MN11	MN10	0 to 59	00h	
02h		HR	MIL	0	HR21	HR20	HR13	HR12	HR11	HR10	0 to 23	00h	
03h		DT	0	0	DT21	DT20	DT13	DT12	DT11	DT10	1 to 31	01h	
04h		MO	0	0	0	MO20	MO13	MO12	MO11	MO10	1 to 12	01h	
05h		YR	YR23	YR22	YR21	YR20	YR13	YR12	YR11	YR10	0 to 99	00h	
06h		DW	0	0	0	0	0	DW2	DW1	DW0	0 to 6	00h	
07h		SS	0	0	0	0	SS3	SS2	SS1	SS0	0 to 9	00h	
08h	Status	SRDC	BMODE	DSTADJ	ALM1	ALM0	LVDD	LBAT85	LBAT75	RTCF	N/A	01h	
09h		SRAC	X	X	X	XOSCF	X	X	ACFAIL	ACRDY	N/A	00h	
0Ah	Counter	ACCNT	AXC7	AXC6	AXXC5	AXC4	AXC3	AXC2	AXC1	AXC0	0 to 127	00h	
0Bh		EVCNT	EVC7	EVC6	EVC5	EVC4	EVC3	EVC2	EVC1	EVC0	0 to 127	00h	
0Ch	Control	INT	ARST	WRTC	IM	X	X	X	ALE1	ALE0	N/A	01h	
0Dh		FO	X	X	X	FOBATB	X	FO2	FO1	FO0	N/A	00h	
0Eh		EVIC	X	EVBATB	EVIM	EVEN	EHYS1	EHYS0	ESMP1	ESMP0	N/A	00h	
0Fh		EVIX	X	X	X	X	X	0	EVIX1	EVIX0	N/A	00h	
10h		TRICK	X	X	X	X	X	TRKEN	TRKRO1	TRKRO0	N/A	00h	
11h		PWRVDD	CLRTS	X	I2CBAT	LVENB	X	VDDTrip2	VDDTrip1	VDDTrip0	N/A	00h	
12h		PWRBAT	X	BHYS	VB85Tp2	VB85Tp1	VB85Tp0	BV75Tp2	BV75Tp1	BV75Tp0	N/A	00h	
13h		AC	AC5060	ACENB	ACRP1	ACRP0	ACFP1	ACFP0	ACFC1	ACFC0	N/A	00h	
14h	FTR	X	X	X	ACMIN	XDTR3	XDTR2	XDTR1	XDTR0	N/A	00h		
15h	DSTCR	DstMoFd	DSTE	0	0	MoFd20	MoFd13	MoFd12	MoFd11	MoFd10	1 to 12	04h	
16h		DstDwFd	0	DwFdE	WkFd12	WkFd11	WkFd10	DwFd12	DwFd11	DwFd10	0 to 6	00h	
17h		DstDI	0	0	DI	DI21	DI20	DI13	DI12	DI11	DI10	1 to 31	01h
18h		DstHrFd	HrFdMIL	0	HrFd21	HrFd20	HrFd13	HrFd12	HrFd11	HrFd10	0 to 23	02h	
19h		DstMoRv	0	0	0	MoRv20	MoRv13	MoRv12	MoRv11	MoRv10	1 to 12	10h	
1Ah		DstDwRv	0	DwRvE	WkRv12	WkRv11	WkRv10	DwRv12	DwRv11	DwRv10	0 to 6	00h	
1Bh		DstDIRv	0	0	DIRv21	DIRv20	DIRv13	DIRv12	DIRv11	DIRv10	1 to 31	01h	
1Ch		DstHrRv	HrRvMIL	0	HrRv21	HrRv20	HrRv13	HrRv12	HrRv11	HrRv10	0 to 23	02h	
1Dh	Alarm0	SCA0	ESCA0	SCA022	SCA021	SCA020	SCA013	SCA012	SCA011	SCA010	0 to 59	00h	
1Eh		MNA0	EMNA0	MNA021	MNA020	MNA013	MNA012	MNA011	MNA010	MNA010	0 to 59	00h	
1Fh		HRA0	EHRA0	0	HRA021	HRA020	HRA013	HRA012	HRA011	HRA010	0 to 23	00h	
20h		DTA0	EDTA0	0	DTA021	DTA020	DTA013	DTA012	DTA011	DTA010	1 to 31	01h	
21h		MOA0	EMOA0	0	0	MOA020	MOA013	MOA012	MOA011	MOA010	1 to 12	01h	
22h		DWA0	EDWA0	0	0	0	0	DWA02	DWA01	DWA00	0 to 6	00h	

TABLE 1. REGISTER MEMORY MAP (X indicates writes to these bits have no effect on the device) (Continued)

ADDR	SECTION	REG NAME	BIT								RANGE	DEFAULT
			7	6	5	4	3	2	1	0		
23h	Alarm1	SCA1	ESCA1	SCA122	SCA121	SCA120	SCA113	SCA112	SCA111	SCA110	0 to 59	00h
24h		MNA1	EMNA1	MNA122	MNA121	MNA120	MNA113	MNA112	MNA111	MNA110	0 to 59	00h
25h		HRA1	EHRA1	0	HRA121	HRA120	HRA113	HRA112	HRA111	HRA110	0 to 23	00h
26h		DTA1	EDTA1	0	DTA121	DTA120	DTA113	DTA112	DTA111	DTA110	1 to 31	01h
27h		MOA1	EMOA1	0	0	MOA120	MOA113	MOA112	MOA111	MOA110	1 to 12	01h
28h		DWA1	EDWA1	0	0	0	0	DWA12	DWA11	DWA10	0 to 6	00h
29h	TSV2B	SCVB	X	SCBV22	SCBV21	SCBV20	SCVB13	SCVB12	SCVB11	SCVB10	0 to 59	00h
2Ah		MNVB	X	MNVB22	MNVB21	MNVB20	MNVB13	MNVB12	MNVB11	MNVB10	0 to 59	00h
2Bh		HRVB	MILVB	X	HRVB21	HRVB20	HRVB13	HRVB12	HRVB11	HRVB10	0 to 23	00h
2Ch		DTVB	X	X	DTVB21	DTVB20	DTVB13	DTVB12	DTVB11	DTVB10	1 to 31	00h
2Dh		MOVB	X	X	X	MOVB20	MOVB13	MOVB12	MOVB11	MOVB10	1 to 12	00h
2Eh	TSB2V	SCBV	X	SCBV22	SCBV21	SCBV20	SCBV13	SCBV12	SCBV11	SCBV10	0 to 59	00h
2Fh		MNBV	X	MNBV22	MNBV21	MNBV20	MNBV13	MNBV12	MNBV11	MNBV10	0 to 59	00h
30h		HRBV	MILBV	X	HRBV21	HRBV20	HRBV13	HRBV12	HRBV11	HRBV10	0 to 23	00h
31h		DTBV	X	X	DTBV21	DTBV20	DTBV13	DTBV12	DTBV11	DTBV10	1 to 31	00h
32h		MOBV	X	X	X	MOBV20	MOBV13	MOBV12	MOBV11	MOBV10	1 to 12	00h
33h	TSEVT	SCT	X	SCT22	SCT21	SCT20	SCT13	SCT12	SCT111	SCT10	0 to 59	00h
34h		MNT	X	MNT22	MNT21	MNT20	MNT13	MNT12	MNT11	MNT10	0 to 59	00h
35h		HRT	MILT	X	HRT21	HRT20	HRT13	HRT12	HRT11	HRT10	0 to 23	00h
36h		DTT	X	X	DTT21	DTT20	DTT13	DTT12	DTT11	DTT10	1 to 31	00h
37h		MOT	X	X	X	MOT20	MOT13	MOT12	MOT11	MOT10	1 to 12	00h

Real Time Clock Registers

Addresses [00h to 07h]

RTC REGISTERS (SC, MN, HR, DT, MO, YR, DW, SS)

These registers depict BCD representations of the time. As such, SC (Seconds) and MN (Minutes) range from 0 to 59, HR (Hour) can be either 12-hour or 24-hour mode, DT (Date) is 1 to 31, MO (Month) is 1 to 12, YR (Year) is 0 to 99, DW (Day of the Week) is 0 to 6, and SS (Sub-Second) is 0 to 9. The Sub-Second register is read-only and will clear to "0" count each time there is a write to a register in the RTC section.

The DW register provides a Day of the Week status and uses three bits DW2 to DW0 to represent the seven days of the week. The counter advances in the cycle 0-1-2-3-4-5-6-0-1-2.... The assignment of a numerical value to a specific day of the week is arbitrary and may be decided by the system software designer. The default value is defined as "0".

24 HOUR TIME

If the MIL bit of the HR register is "1", the RTC uses a 24-hour format. If the MIL bit is "0", the RTC uses a 12-hour format and HR21 bit functions as an AM/PM indicator with a

"1" representing PM. The clock defaults to 12-hour format time with HR21 = "0".

LEAP YEARS

Leap years add the day February 29 and are defined as those years that are divisible by 4. Years divisible by 100 are not leap years, unless they are also divisible by 400. This means that the year 2000 is a leap year and the year 2100 is not. The ISL12032 does not correct for the leap year in the year 2100.

Status Registers (SR)

Addresses [08h to 09h]

The Status Registers consist of the DC and AC status registers (see Tables 2 and 3).

Status Register (SRDC)

The Status Register DC is located in the memory map at address 08h. This is a volatile register that provides status of RTC failure (RTCF), Battery Level Monitor (LBAT85, LBAT75), V_{DD} level monitor (LVDD), Alarm0 or Alarm1 trigger, Daylight Saving Time adjustment, and Battery active mode.

TABLE 2. STATUS REGISTER DC (SRDC)

ADDR	7	6	5	4	3	2	1	0
08h	BMODE	DSTADJ	ALM1	ALM0	LVDD	LBAT85	LBAT75	RTCF

BATTERY ACTIVE MODE (BMODE)

BMODE Indicates that the device is operating from the VBAT input. A “1” indicates Battery Mode and a “0” indicates power from V_{DD} mode. The I2CBAT bit must be set to “1” and the device must be in VBAT mode in order for a valid “1” read from this bit.

DAYLIGHT SAVING TIME ADJUSTMENT BIT (DSTADJ)

DSTADJ is the Daylight Saving Time Adjustment Bit. It indicates that daylight saving time adjustment has happened. The bit will be set to “1” when the Forward DST event has occurred. The bit will stay set until the Reverse DST event has happened. The bit will also reset to “0” when the DSTE bit is set to “0” (DST function disabled). The bit can be forced to “1” with by writing “F0h” to the Status Register. The default value for DSTADJ is “0”.

ALARM BITS (ALM0 AND ALM1)

These bits announce if an alarm matches the real time clock. If there is a match, the respective bit is set to “1”. This bit can be manually reset to “0” by the user or automatically reset by enabling the auto-reset bit (see ARST bit). A write to this bit in the SR can only set it to “0”, not “1”. An alarm bit that is set by an alarm occurring during an SR read operation will remain set after the read operation is complete.

LOW V_{DD} INDICATOR BIT (LVDD)

Indicates V_{DD} dropped below the pre-selected trip level. (Brownout Mode). The Trip points for Brownout levels are selected by three bits VDDTrip2, VDDTrip1 and VDDTrip0 in the PWRVDD registers.

LOW BATTERY INDICATOR 85% BIT (LBAT85)

Indicates battery level dropped below the pre-selected trip level (85% of battery voltage). The trip point is set by three bits: VB85Tp2, VB85Tp1 and VB85Tp0 in the PWRBAT register.

LOW BATTERY INDICATOR 75% BIT (LBAT75)

Indicates battery level dropped below the pre-selected trip level (75% of battery voltage). The trip point is set by three bits: VB75Tp2, VB75Tp1 and VB75Tp0 in the PWRBAT register.

REAL TIME CLOCK FAIL BIT (RTCF)

This bit is set to a “1” after a total power failure. This is a read only bit that is set by hardware (internally) when the device powers up after having lost all power (defined as $V_{DD} = 0V$ and $VBAT = 0V$). The bit is set regardless of whether V_{DD} or VBAT is applied first. The loss of only one of the supplies does not set the RTCF bit to “1”. The first valid write to the RTC section after a complete power failure resets the RTCF bit to “0” (writing one byte is sufficient).

Status Register (SRAC)

TABLE 3. STATUS REGISTER AC (SRAC)

ADDR	7	6	5	4	3	2	1	0
09h	X	X	X	XOSCF	X	X	ACFAIL	ACRDY

The Status Register AC is located in the memory map at address 09h. This is a volatile register that provides status of Crystal Failure (XOSCF), AC Failed (ACFAIL) and AC Ready (ACRDY).

CRYSTAL OSCILLATOR FAIL BIT (XOSCF)

Indicates Crystal Oscillator has stopped if XOSCF = 1. When the crystal oscillator has resumed operation, the XOSCF bit is reset to “0”.

AC FAIL (ACFAIL)

This bit announces the status of the AC input. If ACFAIL = 1, then the AC input frequency and amplitude qualification check has failed. ACFAIL is reset to “0” when the AC input meets the preset requirements (see “AC (AC Input)” on page 8).

AC READY (ACRDY)

This bit announces the status of the AC input. If ACRDY = 1, then the AC input has passed the qualification parameter check (as set by ACFC and ACFP bits) for the time prescribed by ACRP and is used for the RTC clock. When ACRDY = 0 the AC input failed the qualification requirements and the crystal oscillator clock is used for the RTC clock (see “AC (AC Input)” on page 8).

When ACFAIL transitions from “1” to “0” (from failed to pass), then the timer set by ACRP will determine the delay until ACRDY transitions from “0” to “1”. ACRDY will be set to “0” immediately after ACRDY is set to “0” (failed AC input), indicating the crystal oscillator is the RTC clock.

Counter Registers**Addresses [0Ah to 0Bh]**

These registers will count the number of times AC failure occurs and the number of times an event occurs. These registers are 8-bits each and will count up to 255.

AC COUNT (ACCNT)

TABLE 4. AC COUNTER REGISTER (ACCNT)

ADDR	7	6	5	4	3	2	1	0
0Ah	AXC7	AXC6	AXC5	AXC4	AXC3	AXC2	AXC1	AXC0

The ACCNT register increments automatically each time the AC input switches to the crystal backup. The register is set to 00h on initial power-up. The maximum count is 255, and will stay at that value until set to zero via an I²C write.

Event Count (EVCNT)**TABLE 5. EVENT COUNTER REGISTER (EVCNT)**

ADDR	7	6	5	4	3	2	1	0
0Bh	EVC7	EVC6	EVC5	EVC4	EVC3	EVC2	EVC1	EVC0

The EVCNT register increments automatically each time an event occurs. The register is set to 00h on initial power-up. The maximum count is 255, and will stay at that value until set to zero via an I²C write.

Performing a write of 00h to this register will clear the contents of this register and all levels of the TSEVT section. A clear to this register should be done with care. Write event index register zero only selects first event time stamp. Write event count EVNVCNT zero will both clear event counter and all time stamps.

Control Registers**Addresses [0Ch to 14h]**

The control registers (INT, FO, EVIC, EVIX, TRICK, PWRVDD, PWRBAT, AC, and FTR) contain all the bits necessary to control the parametric functions on the ISL12032.

Interrupt Control Register (INT)**TABLE 6. INTERRUPT CONTROL REGISTER (INT)**

ADDR	7	6	5	4	3	2	1	0
0Ch	ARST	WRTC	IM	X	X	X	ALE1	ALE0

AUTOMATIC RESET BIT (ARST)

This bit enables/disables the automatic reset of the ALM0, ALM1, LVDD, LBAT85, and LBAT75 status bits only. When ARST bit is set to "1", these status bits are reset to "0" after a valid read of the SRDC Register (with a valid STOP condition). When the ARST is cleared to "0", the user must manually reset the ALM0, ALM1, LVDD, LBAT85, and LBAT75 bits.

WRITE RTC ENABLE BIT (WRTC)

The WRTC bit enables or disables write capability into the RTC Register section. The factory default setting of this bit is "0". Upon initialization or power-up, the WRTC must be set to "1" to enable the RTC. Upon the completion of a valid write (STOP), the RTC starts counting. The RTC internal 1Hz signal is synchronized to the STOP condition during a valid write cycle. This bit will remain set until reset to "0" or a complete power-down occurs ($V_{DD} = V_{BAT} = 0.0V$)

ALARM INTERRUPT MODE BIT (IM)

This bit enables/disables the interrupt mode of the alarm function. When the IM bit is set to "1", the alarms will operate in the interrupt mode, where an active low pulse width of 250ms will appear at the \overline{IRQ} pin when the RTC is triggered by either alarm as defined by the Alarm0 section (1Dh to

22h) or the Alarm1 section (23h to 28h). When the IM bit is cleared to "0", the alarm will operate in standard mode, where the \overline{IRQ} pin will be set LOW until both the ALM0/ALM1 status bits are cleared to "0".

ALARM 1 (ALE 1)

This bit enables the Alarm1 function. When ALE1 = "1", a match of the RTC section with the Alarm1 section will result in setting the ALM1 status bit to "1" and the \overline{IRQ} output LOW. When set to "0", the Alarm1 function is disabled.

ALARM 0 (ALE 0)

This bit enables the Alarm0 function. When ALE0 = 1, a match of the RTC section with the Alarm1 section will result in setting the ALM0 status bit to "1" and the \overline{IRQ} output LOW. When set to "0", the Alarm0 function is disabled.

Frequency Out Register (FO)**TABLE 7. FREQUENCY OUT REGISTER (FO)**

ADDR	7	6	5	4	3	2	1	0
0Dh	X	X	X	FOBATB	X	FO2	FO1	FO0

FREQUENCY OUTPUT AND INTERRUPT BIT (FOBATB)

This bit enables/disables F_{OUT} during battery backup mode (i.e. VBAT power source active). When the FOBATB is set to "1" the F_{OUT} pin is disabled during battery backup mode. When the FOBATB is cleared to "0", the F_{OUT} pin is enabled during battery backup mode (default). Note that F_{OUT} is a CMOS output and needs no pull-up resistor. Note also that battery current drain will be higher with F_{OUT} enabled in battery backup mode.

FREQUENCY OUT CONTROL BITS (FO <2:0>)

These bits enable/disable the frequency output function and select the output frequency at the F_{OUT} pin. See Table 8 for frequency selection. Note that frequencies from 4096Hz to 32768Hz are derived from the Crystal Oscillator, and the 1.0, 10, and 50/60Hz frequencies are derived from the AC clock input. The exception to this is when the AC input qualification has failed, and the crystal oscillator is used for the 1.0Hz F_{OUT} .

TABLE 8. FREQUENCY SELECTION OF F_{OUT} PIN

FREQUENCY, F_{OUT}	UNITS	FO2	FO1	FO0
32768	Hz	0	0	0
16372	Hz	0	0	1
8192	Hz	0	1	0
4096	Hz	0	1	1
50/60	Hz	1	0	0
1	Hz	1	0	1
Low	Hz	1	1	0
High	Hz	1	1	1

Event Detection Register (EVIC)

TABLE 9. EVENT DETECTION REGISTER (EVIC)

ADDR	7	6	5	4	3	2	1	0
0Eh	X	EVBATB	EVIM	EVEN	EHYS1	EHYS0	ESMP1	ESMP0

EVENT OUTPUT IN BATTERY MODE ENABLE BIT (EVBATB)

This bit enables/disables the $\overline{\text{EVDET}}$ pin during battery backup mode (i.e. VBAT pin supply ON). When the EVBATB is set to "1", the Event Detect Output is disabled in battery backup mode. When the EVBATB is cleared to "0", the Event Detect output is enabled in battery backup mode. This feature can be used to save power during battery mode.

EVENT OUTPUT PULSE MODE (EVIM)

This bit controls the $\overline{\text{EVDET}}$ pin output mode. With $\text{EVIM} = 0$, the output is in normal mode and when an event is triggered, the output will be set LOW until reset. With $\text{EVIM} = 1$, the output is in pulse mode and when an event is triggered, the device will generate a 200ms to 300ms pulse at the $\overline{\text{EVDET}}$ output.

EVENT DETECT ENABLE (EVEN)

This bit enables/disables the Event Detect function of the ISL12032. When this bit is set to "1", the Event Detect is active. When this bit is cleared to "0", the Event Detect is disabled.

EVENT TIME-BASED HYSTERESIS (EHYS1, EHYS0)

These bits set the amount of time-based hysteresis that is present at the EVIN pin for deglitching the input signal. The settings vary from 0ms (hysteresis OFF) to 31.25ms (delay of 31.25ms to check for change of state at the EVIN pin). The Hysteresis function and the Event Input Sampling function work independently.

TABLE 10. EVENT TIME-BASED HYSTERESIS

EHSYS1	EHSYS0	TIME (ms)
0	0	0
0	1	3.9
1	0	16.625
1	1	31.25

EVENT INPUT SAMPLING RATE (ESMP)

These bits set the frequency of sampling of the Event Input (EVIN). The settings include from 1/4Hz (one sample per 4s) to 2Hz (twice a second), 1Hz, or continuous sampling (Always ON). The less frequent the sampling, the lower the current drain, which can affect battery current drain and battery life.

TABLE 11. EVENT INPUT SAMPLING RATE

ESMP1	ESMP2	SAMPLING RATE
0	0	Always ON
0	1	2 Hz
1	0	1 Hz
1	1	1/4 Hz

Event Index Register (EVIX)

TABLE 12. EVENT INDEX REGISTER (EVIX)

ADDR	7	6	5	4	3	2	1	0
0Fh	X	X	X	X	X	X	EVIX1	EVIX0

The Event Index Register provides the index for locating an individual event that has been stored. The Event recording function allows recalling up to 4 events, although the Event counting register will count up to 255 events. The 0th location corresponds to the first event, and the 1st through 3rd locations correspond to the most recent events, with the 3rd location (11b) representing the latest event. Therefore, setting EVIX to 03h location and reading the TSEVT section will access the timestamp information for the most recent (latest) event. Setting this register to another value will allow reading the corresponding event from the TSEVT section.

EVENT BIT (EVIX <1:0>)

These bits are the Event Counter Register index bits. EVIX1 is the MSB and EVIX0 is the LSB.

Trickle Charge Register (TRICK)

TABLE 13. TRICKLE CHARGE REGISTER (TRICK)

ADDR	7	6	5	4	3	2	1	0
10h	X	X	X	X	X	TRKEN	TRKRO1	TRKRO0

The trickle charge function allows charging current to flow from the V_{DD} supply to the VBAT pin through a selectable current limiting resistor. Disabling the trickle charge function removes this connection and isolates the battery from the V_{DD} supply in the case charging is not necessary or harmful (as in the case with a lithium coin cell battery). Note that there is no charging diode in series with the trickle charge resistor, but a switch network that adds a small series resistance to the charging resistance.

TRICKLE CHARGE BIT (TRKEN)

This bit enables/disables the trickle charge capability for the backup battery supply. Setting this bit to "1" will enable the trickle charge. Resetting this bit to "0" will disable the trickle charge function and isolate the battery from the V_{DD} supply.

TRICKLE CHARGE RESISTOR (TRKRO<1:0>)

These bits allow the user to change the trickle charge resistor settings according to the maximum current desired for the battery or supercapacitor charging.

$$I_{MAX} = \frac{V_{DD} - V_{BAT}}{R_{OUT}} \quad (\text{EQ. 1})$$

Where the R_{OUT} is the selected resistor between V_{DD} and V_{BAT} . Table 14 gives the typical resistor values for $V_{DD} = 5V$ and $V_{BAT} = 3.0V$. Note that the resistor value changes with V_{DD} input voltage and V_{BAT} voltage, as well as with temperature.

TABLE 14. RESISTOR SELECTION REGISTER

TRKRO1	TRKRO0	Rtrk	UNITS
0	0	1300	Ω
0	1	2200	Ω
1	0	3600	Ω
1	1	7800	Ω

Power Supply Control Register (PWRVDD)

TABLE 15. POWER SUPPLY CONTROL REGISTER (PWRVDD)

ADDR	7	6	5	4	3	2	1	0
11h	CLRTS	X	I2CBAT	LVENB	X	VDD Trip2	VDD Trip1	VDD Trip0

CLEAR TIME STAMP BIT (CLRTS)

This bit clears both the Time Stamp V_{DD} to Battery (TSV2B) and Time Stamp Battery to V_{DD} (TSB2V) sections. The default setting is "0" which allows normal operation. Setting CLRTS = 1 performs the clear timestamp register function at the conclusion of a successful write operation.

I²C IN BATTERY MODE (I2CBAT)

This bit allows I²C operation in battery backup mode (VBAT powered) when set to "1". When reset to "0", the I²C operation is disabled in battery mode, which results in the lowest I_{DD} current.

Note that when the I²C operation is desired in VBAT mode, the SCL and SDA pull-ups must go to the VBAT source for proper communications. This will result in additional VBAT current drain (on top of the increased device VBAT current) during serial communications.

V_{DD} BROWNOUT TRIP VOLTAGE (VDDTRIP <2:0>)

These bits set the 6 trip levels for the V_{DD} alarm and VBAT switchover. The LVDD bit in the SRDC is set to "1" when V_{DD} drops below this preset level. See Table 16.

TABLE 16. VDD TRIP LEVELS

V _{DD} Trip2	V _{DD} Trip1	V _{DD} Trip0	TRIP VOLTAGE (V)
0	0	0	2.295
0	0	1	2.550
0	1	0	2.805

TABLE 16. VDD TRIP LEVELS

V _{DD} Trip2	V _{DD} Trip1	V _{DD} Trip0	TRIP VOLTAGE (V)
0	1	1	3.060
1	0	0	4.250
1	0	1	4.675

Battery Voltage Warning Register (PWRVBAT)

This register controls the trip points for the two VBAT warnings, with levels set to approximately 85% and 75% of the nominal battery level.

TABLE 17. BATTERY VOLTAGE WARNING REGISTER (PWRVBAT)

ADDR	7	6	5	4	3	2	1	0
12h	X	BHYS	VB85T p2	VB85T p1	VB85T p0	VB75T p2	VB75T p1	VB75T p0

VBAT HYSTERESIS (BHYS)

This bit enables/disables the hysteresis voltage for the V_{DD} /VBAT switchover. When set to "1", hysteresis is enabled and switching to VBAT occurs at approximately 50mV below the V_{DD} Trip point (set by VDDTrip<2:0>). Switching from VBAT to V_{DD} power will occur at approximately 50mV above the V_{DD} trip point.

When set to "0", there is no hysteresis and switchover will occur at exactly the V_{DD} trip point. Note that for slow moving V_{DD} power-down and power-up signals there can be some extra switching cycles without hysteresis.

BATTERY LEVEL MONITOR TRIP BITS (VB85TP <2:0>)

Three bits selects the first alarm (85% of Nominal VBAT) level for the battery voltage monitor. There are total of 7 levels that could be selected for the first warning. Any of the levels could be selected as the first warning with no reference as to nominal VBAT voltage level. See Table 18 for typical values.

TABLE 18. VB85T VBAT WARNING LEVELS

VB85Tp2	VB85Tp1	VB85Tp0	BATTERY ALARM TRIP LEVEL (V)
0	0	0	2.125
0	0	1	2.295
0	1	0	2.550
0	1	1	2.805
1	0	0	3.060
1	0	1	4.250
1	1	0	4.675

BATTERY LEVEL MONITOR TRIP BITS (VB75TP <2:0>)

Three bits selects the second warning (75% of Nominal VBAT) level for the battery voltage monitor. There are total of 7 levels that could be selected for the second monitor. Any of the levels could be selected as the second alarm with no reference as to nominal VBAT voltage level. See Table 19 for typical values.

TABLE 19. VB75T VBAT WARNING LEVELS

VB75Tp2	VB75Tp1	VB75Tp0	BATTERY ALARM TRIP LEVEL (V)
0	0	0	1.875
0	0	1	2.025
0	1	0	2.250
0	1	1	2.475
1	0	0	2.700
1	0	1	3.750
1	1	0	4.125

AC Register (AC)

This register sets the performance screening for the AC input.

TABLE 20. AC REGISTER

ADDR	7	6	5	4	3	2	1	0
13h	AC5060	ACENB	ACRP1	ACRP0	ACFP1	ACFP0	ACFC1	ACFC0

AC 50/60HZ INPUT SELECT (AC5060)

This bit selects either 50Hz or 60Hz powerline AC clock input frequency. Setting this bit to "0" selects a 60Hz input (default). Setting this bit to "1" selects a 50Hz input.

AC ENABLE (ACENB)

This bit will enable/disable the AC clock input. Setting this bit to "0" will enable the AC clock input (default). Setting this bit to "1" will disable the AC clock input. When the AC input is disabled, the crystal oscillator becomes the sole source for RTC and F_{OUT} clocking.

AC RECOVERY PERIOD (ACRP<1:0>)

This bit sets the AC clock input validation recovery period. After the AC input fails validation (ACFAIL = 1), a predefined period is used to test the frequency and voltage of the AC clock input. The range is from 2s to 16s.

TABLE 21. AC RECOVERY PERIOD

ACRP1	ACRP0	RECOVERY TIME
0	0	2s
0	1	4s
1	0	8s
1	1	16s

AC FAILURE CYCLES (ACFP<1:0>)

These two bits determine how many AC cycles are used for the AC clock qualification, or to disable the AC clock qualification. The range is from 1 AC cycle to 12 AC cycles or disable, and is also dependent on the AC5060 bit setting (see Table 22). The qualification logic will count the number of crystal cycles in the chosen AC period, and if the count is outside the window set by ACFC bits then the ACFAIL signal is set to "1".

For example, if 10 cycles are chosen for 50Hz input, then during those 10 cycles there would need to be exactly 6554 crystal cycles. That number is subtracted from the actual count during the 10 AC cycles and the absolute value is compared to the error value set by ACFC. If the error were 10 crystal cycles and ACFC were set to 11b, then the allowable error would be 20 crystal cycles and the ACFAIL would be "0", or qualification has passed. If the actual error count were 22 cycles then the ACFAIL would be set to "1", qualification has failed.

TABLE 22. AC FAILURE CYCLES

CYCLE USED for COUNT		ACFP1	ACFP0
AC5060 = 0	AC5060=1		
(Disabled)		0	0
1	1	0	1
6	5	1	0
12	10	1	1

AC/CRYSTAL FREQUENCY FAILURE CRITERION (ACFC<1:0>)

These two bits determine the number of crystal cycles used for the error budget for the AC qualification (see Table 24). Two of the choices are for a fixed ppm criterion of 1 or 2 crystal cycles in just one AC cycle (independent of the ACFP setting). The other choices are for 1 or 2 crystal cycles per AC cycle, but includes the total number of cycles set by the ACFP.

Using the example given for the ACFP bits previously mentioned:

AC5060 = 1 (50Hz)

ACFC = 11b (2 crystal cycles/AC cycle)

ACFP = 11b (10 total AC cycles)

So the resulting crystal cycle count must be within:

$\pm(10 \text{ AC cycles} \times 2 \text{ crystal cycles/AC cycle})$ or

± 20 total crystal cycles (error budget) as shown in Table 23.

TABLE 23. AC/CRYSTAL FREQUENCY FAILURE CRITERION

ACFC1	ACFC0	CRITERION	TOTAL XTAL CYCLE ERROR BUDGET
0	0	1 crystal cycle per AC cycle	ACFP x 1
0	1	2 crystal cycle per AC cycle	ACFP x 2
1	0	1 crystal cycle in all AC cycles	1
1	1	2 crystal cycles in all AC cycles	2

Fine Trim Compensation Register (FTR)

This register (Table 24) provides control of the crystal oscillator clock compensation and the AC clock input minimum level detect.

TABLE 24. FINE TRIM COMPENSATION REGISTER

ADDR	7	6	5	4	3	2	1	0
14h	X	X	X	ACMIN	XDTR3	XDTR2	XDTR1	XDTR0

AC MINIMUM (ACMIN)

This bit determines the minimum peak-to-peak voltage level for the AC clock input as a percentage of the existing V_{DD} supply. $ACMIN = 0$ sets the minimum level to $5\% \times V_{DD}$. $ACMIN = 1$ sets the minimum level to $10\% \times V_{DD}$.

DIGITAL TRIM REGISTER (XDTR<3:0>)

The digital trim register bits control the amount of trim used to adjust for the crystal clock error. This trim is accomplished by adding or subtracting the 32kHz clock in the clock counter chain to adjust the RTC clock. Calibration can be done by monitoring the F_{OUT} pin with a frequency counter with the frequency output set to 1.0Hz, with no AC input.

TABLE 25. XDTR FREQUENCY COMPENSATION

XDTR3	XDTR2	XDTR1	XDTR0	FREQUENCY COMPENSATION (ppm)
0	0	0	0	0
0	0	0	1	10
0	0	1	0	20
0	0	1	1	30
0	1	0	0	40
0	1	0	1	50
0	1	1	0	60
0	1	1	1	0
1	0	0	0	0
1	0	0	1	-10
1	0	1	0	-20
1	0	1	1	-30
1	1	0	0	-40
1	1	0	1	-50
1	1	1	0	-60
1	1	1	1	0

DST Control Registers (DSTCR)

8 bytes of control registers have been assigned for the Daylight Savings Time (DST) functions. DST beginning (set Forward) time is controlled by the registers $DstMoFd$, $DstDwFd$, $DstDtFd$, and $DstHrFd$. DST ending time (set Backward or Reverse) is controlled by $DstMoRv$, $DstDwRv$, $DstDtRv$ and $DstHrRv$.

Tables 26 and 27 describe the structure and functions of the DSTCR.

DST FORWARD REGISTERS (15H TO 18H)

DSTE is the DST Enabling Bit located in bit 7 of register 15h ($DstMoFdxx$). Set $DSTE = 1$ will enable the DSTE function. Upon powering up for the first time (including battery), the DSTE bit defaults to "0".

DST forward is controlled by the following DST Registers:

$DstMoFd$ sets the Month that DST starts. The default value for the DST begin month is April (04h).

$DstDwFd$ sets the Day of the Week that DST starts.

$DstDwFdE$ sets the priority of the Day of the Week over the Date. For $DstDwFdE=1$, Day of the week is the priority. Note that Day of the week counts from 0 to 6, like the RTC registers. The default for the DST Forward Day of the Week is Sunday (00h).

$DstDtFd$ controls which Date DST begins. The default value for DST forward date is on the first date of the month (01h). $DstDtFd$ is only effective if $DstDwFdE = 0$.

DstHrFd controls the hour that DST begins. It includes the MIL bit, which is in the corresponding RTC register. The RTC hour and DstHrFd registers need to match formats (Military or AM/PM) in order for the DST function to work. The default value for DST hour is 2:00AM (02h). The time is advanced from 2:00:00AM to 3:00:00AM for this setting.

DST REVERSE REGISTERS (19H TO 1CH)

DST end (reverse) is controlled by the following DST Registers.

DstMoRv sets the Month that DST ends. The default value for the DST end month is October (10h).

DstDwRv controls the Day of the Week that DST should end. The DwRvE bit sets the priority of the Day of the Week over

the Date. For DwRvE = 1, Day of the week is the priority. Note that Day of the week counts from 0 to 6, like the RTC registers. The default for DST DwRv end is Sunday (00h).

DstDtRv controls which Date DST ends. The default value for DST Date Reverse is on the first date of the month. The DstDtRv is only effective if the DwRvE = 0.

DstHrRv controls the hour that DST ends. It includes the MIL bit, which is in the corresponding RTC register. The RTC hour and DstHrRv registers need to match formats (Military or AM/PM) in order for the DST function to work. The default value sets the DST end at 2:00AM. The time is set back from 2:00:00AM to 1:00:00AM for this setting.

TABLE 26. DST FORWARD REGISTERS

ADDRESS	FUNCTION	7	6	5	4	3	2	1	0
15h	Month Forward	DSTE	0	0	MoFd20	MoFd13	MoFd12	MoFd11	MoFd10
16h	Day Forward	0	DwFdE	WkFd12	WkFd11	WkFd10	DwFd12	DwFd11	DwFd10
17h	Date Forward	0	0	DtFd21	DtFd20	DtFd13	DtFd12	DtFd11	DtFd10
18h	Hour Forward	HrFdMIL	0	HrFd21	HrFd20	HrFd13	HrFd12	HrFd11	HrFd10

TABLE 27. DST REVERSE REGISTERS

ADDRESS	NAME	7	6	5	4	3	2	1	0
19h	Month Reverse	0	0	0	MoRv20	MoRv13	MoRv12	MoRv11	MoRv10
1Ah	Day Reverse	0	DwRvE	WkRv12	WkRv11	WkRv10	DwRv12	DwRv11	DwRv10
1Bh	Date Reverse	0	0	DtRv21	DtRv20	DtRv13	DtRv12	DtRv11	DtRv10
1Ch	Hour Reverse	HrRvMIL	0	HrRv21	HrRv20	HrRv13	HrRv12	HrRv11	HrRv10

ALARM Registers (1Dh to 28h)

The alarm register bytes are set up identical to the RTC register bytes, except that the MSB of each byte functions as an enable bit (enable = "1"). These enable bits specify which alarm registers (seconds, minutes, etc.) are used to make the comparison. Note that there is no alarm byte for year.

The alarm function works as a comparison between the alarm registers and the RTC registers. As the RTC advances, the alarm will be triggered once a match occurs between the alarm registers and the RTC registers. Any one alarm register, multiple registers, or all registers can be enabled for a match.

There are two alarm operation modes: Single Event and periodic Interrupt Mode:

Single Event Mode is enabled by setting either ALE0 or ALE1 to 1, then setting bit 7 on any of the Alarm registers (ESCA... EDWA) to "1", and setting the IM bit to "0". This mode permits a one-time match between the Alarm registers and the RTC registers. Once this match occurs, the ALM bit is set to "1" and the $\overline{\text{IRQ}}$ output will be pulled LOW and will remain LOW until the ALM bit is reset. This can be done

manually or by using the auto-reset feature. Since the $\overline{\text{IRQ}}$ output is shared by both alarms, they both need to be reset in order for the $\overline{\text{IRQ}}$ output to go HIGH.

Interrupt Mode is enabled by setting either ALE0 or ALE1 to 1, then setting bit 7 on any of the Alarm registers (ESCA... EDWA) to "1", and setting the IM bit to "1". Setting the IM bit to 1 puts both ALM0 and ALM1 into Interrupt mode. The $\overline{\text{IRQ}}$ output will now be pulsed each time an alarm occurs (either AL0 or AL1). This means that once the interrupt mode alarm is set, it will continue to alarm until it is reset.

To clear a single event alarm, the corresponding ALM0 or ALM1 bit in the SRDC register must be set to "0" with a write. Note that if the ARST bit is set to "1" (address 0Ch, bit 7), the ALM0 and ALM1 bits will automatically be cleared when the status register is read.

The $\overline{\text{IRQ}}$ output will be set by an alarm match for either ALM0 or ALM1.

Following are examples of both Single Event and periodic Interrupt Mode alarms.

Example 1

- Alarm set with single interrupt (IM = "0")
- A single alarm will occur on January 1 at 11:30am.
- Set Alarm registers as follows:

ALARM REGISTER	BIT								HEX	DESCRIPTION
	7	6	5	4	3	2	1	0		
SCA0	0	0	0	0	0	0	0	0	00h	Seconds disabled
MNA0	1	0	1	1	0	0	0	0	B0h	Minutes set to 30, enabled
HRA0	1	0	0	1	0	0	0	1	91h	Hours set to 11, enabled
DTA0	1	0	0	0	0	0	0	1	81h	Date set to 1, enabled
MOA0	1	0	0	0	0	0	0	1	81h	Month set to 1, enabled
DWA0	0	0	0	0	0	0	0	0	00h	Day of week disabled

After these registers are set, an alarm will be generated when the RTC advances to exactly 11:30 a.m. on January 1 (after seconds changes from 59 to 00) by setting the ALM0 bit in the status register to "1" and also bringing the IRQ output LOW.

Example 2

- Pulsed interrupt once per minute (IM = "1")
- Interrupts at one minute intervals when the seconds register is at 30 seconds.
- Set Alarm registers as follows:

ALARM REGISTER	BIT								HEX	DESCRIPTION
	7	6	5	4	3	2	1	0		
SCA0	1	0	1	1	0	0	0	0	B0h	Seconds set to 30, enabled
MNA0	0	0	0	0	0	0	0	0	00h	Minutes disabled
HRA0	0	0	0	0	0	0	0	0	00h	Hours disabled
DTA0	0	0	0	0	0	0	0	0	00h	Date disabled
MOA0	0	0	0	0	0	0	0	0	00h	Month disabled
DWA0	0	0	0	0	0	0	0	0	00h	Day of week disabled

Once the registers are set, the following waveform will be seen at IRQ:

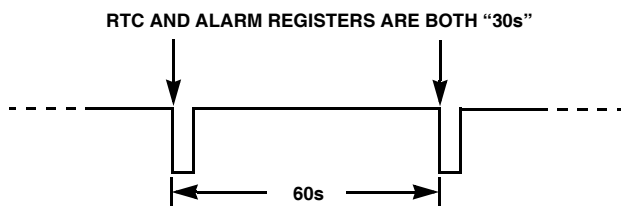

FIGURE 5. IRQ WAVEFORM

Note that the status register ALM0 bit will be set each time the alarm is triggered, but does not need to be read or cleared.

Time Stamp V_{DD} to Battery Registers (TSV2B)

The TSV2B section bytes are identical to the RTC register section, except they do not extend beyond the Month. The Time Stamp captures the FIRST V_{DD} to Battery Voltage transition time, and will not update upon subsequent events, until cleared (only the first event is captured before clearing). Set CLRSTS = 1 to clear this register (Addr 11h, PWRVDD register).

Time Stamp Battery to V_{DD} Registers (TSB2V)

The Time Stamp Battery to V_{DD} section bytes are identical to the RTC section bytes, except they do not extend beyond Month. The Time Stamp captures the LAST transition of VBAT to V_{DD} (only the last power up event of a series of power up/down events is retained). Set CLRSTS = 1 to clear this register (Addr 11h, PWRVDD register).

Time Stamp Event Registers (TSEVT)

The TSEVT section bytes are identical to the RTC section bytes, except they do not extend beyond the Month. The Time Stamp captures the first event and the most recent three events. The first event Time Stamp will not update until cleared. All 4 Time Stamps are all cleared to "0" when writing the event counter (0Bh) is set to "0".

Note: The time stamp registers are cleared to all "0", including the month and day, which is different from the RTC and alarm registers (those registers default to 01h). This is the indicator that no time stamping has occurred since the last clear or initial power-up. Once a time stamp occurs, there will be a non-zero time stamp.

User Memory Registers (accessed by using Slave Address 1010111x)**Addresses [00h to 7Fh]**

These registers are 128 bytes of battery-backed user SRAM. Writes to this section do not need to be preceded by setting the WRTC bit.

I²C Serial Interface

The ISL12032 supports a bi-directional bus oriented protocol. The protocol defines any device that sends data onto the bus as a transmitter and the receiving device as the receiver. The device controlling the transfer is the master and the device being controlled is the slave. The master always initiates data transfers and provides the clock for both transmit and receive operations. Therefore, the ISL12032 operates as a slave device in all applications.

All communication over the I²C interface is conducted by sending the MSB of each byte of data first.

Protocol Conventions

Data states on the SDA line can change only during SCL LOW periods. SDA state changes during SCL HIGH are reserved for indicating START and STOP conditions (see Figure 6). On power-up of the ISL12032, the SDA pin is in the input mode.

All I²C interface operations must begin with a START condition, which is a HIGH to LOW transition of SDA while SCL is HIGH. The ISL12032 continuously monitors the SDA and SCL lines for the START condition and does not respond to any command until this condition is met (see Figure 6). A START condition is ignored during the power-up sequence.

All I²C interface operations must be terminated by a STOP condition, which is a LOW to HIGH transition of SDA while

SCL is HIGH (see Figure 6). A STOP condition at the end of a read operation or at the end of a write operation to memory only places the device in its standby mode.

An acknowledge (ACK) is a software convention used to indicate a successful data transfer. The transmitting device, either master or slave, releases the SDA bus after transmitting eight bits. During the ninth clock cycle, the receiver pulls the SDA line LOW to acknowledge the reception of the eight bits of data (see Figure 7).

The ISL12032 responds with an ACK after recognition of a START condition followed by a valid Identification Byte, and once again after successful receipt of an Address Byte. The ISL12032 also responds with an ACK after receiving a Data Byte of a write operation. The master must respond with an ACK after receiving a Data Byte of a read operation.

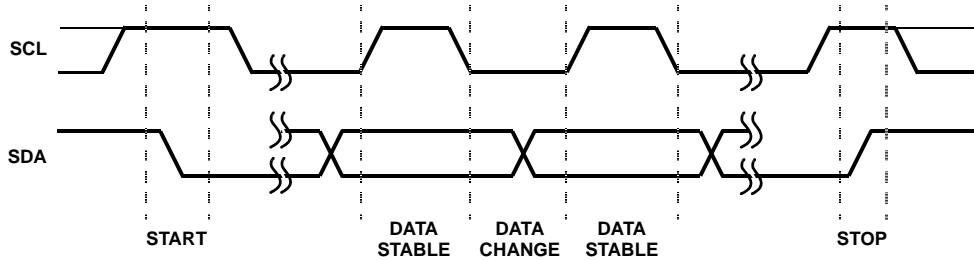

FIGURE 6. VALID DATA CHANGES, START AND STOP CONDITIONS

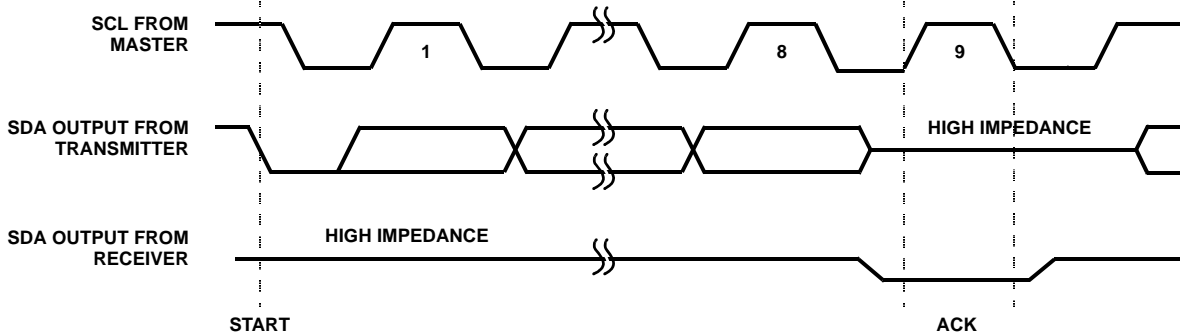

FIGURE 7. ACKNOWLEDGE RESPONSE FROM RECEIVER

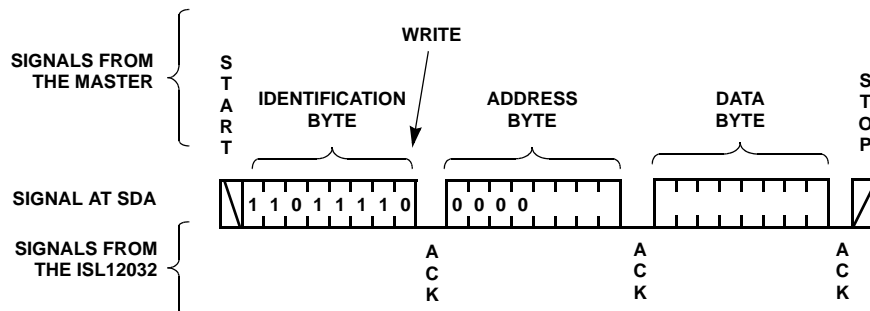

FIGURE 8. BYTE WRITE SEQUENCE (SLAVE ADDRESS FOR CSR SHOWN)

Device Addressing

Following a start condition, the master must output a Slave Address Byte. The 7 MSBs are the device identifier. These bits are “1101111b” for the RTC registers and “1010111b” for the User SRAM.

The last bit of the Slave Address Byte defines a read or write operation to be performed. When this $\overline{R/W}$ bit is a “1”, then a read operation is selected. A “0” selects a write operation (refer to Figure 9).

After loading the entire Slave Address Byte from the SDA bus, the ISL12032 compares the device identifier and device select bits with “1101111b” or “1010111b”. Upon a correct compare, the device outputs an acknowledge on the SDA line.

Following the Slave Byte is a one byte word address. The word address is either supplied by the master device or obtained from an internal counter. On power up the internal address counter is set to address 00h, so a current address read starts at address 00h. When required, as part of a random read, the master must supply the 1 Word Address Byte as shown in Figure 9.

In a random read operation, the slave byte in the “dummy write” portion must match the slave byte in the “read” section. For a random read of the Control/Status Registers, the slave byte must be “1101111x” in both places.

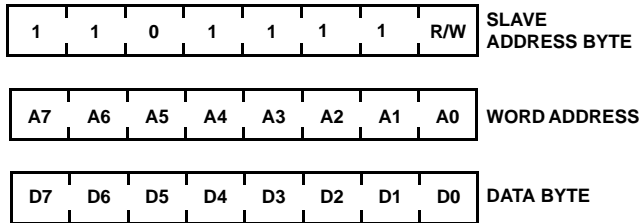

FIGURE 9. SLAVE ADDRESS, WORD ADDRESS, AND DATA BYTES

Write Operation

A Write operation requires a START condition, followed by a valid Identification Byte, a valid Address Byte, a Data Byte, and a STOP condition. After each of the three bytes, the ISL12032 responds with an ACK. At this time, the I²C interface enters a standby state.

A multiple byte operation within a page is permitted. The Address Byte must have the start address, and the data bytes are sent in sequence after the address byte, with the ISL12032 sending an ACK after each byte. The page write is terminated with a STOP condition from the master. The pages within the ISL12032 do not support wrapping around for page read or write operations.

Read Operation

A Read operation consists of a three byte instruction followed by one or more Data Bytes (see Figure 10). The master initiates the operation issuing the following sequence: a START, the Identification byte with the $\overline{R/W}$ bit set to “0”, an Address Byte, a second START, and a second Identification byte with the $\overline{R/W}$ bit set to “1”. After each of the three bytes, the ISL12032 responds with an ACK. Then the ISL12032 transmits Data Bytes as long as the master responds with an ACK during the SCL cycle following the eighth bit of each byte. The master terminates the read operation (issuing a STOP condition) following the last bit of the last Data Byte (see Figure 10).

The Data Bytes are from the memory location indicated by an internal pointer. This pointer's initial value is determined by the Address Byte in the Read operation instruction, and increments by one during transmission of each Data Byte. After reaching the last memory location in a section or page, the master should issue a STOP. Bytes that are read at addresses higher than the last address in a section may be erroneous.

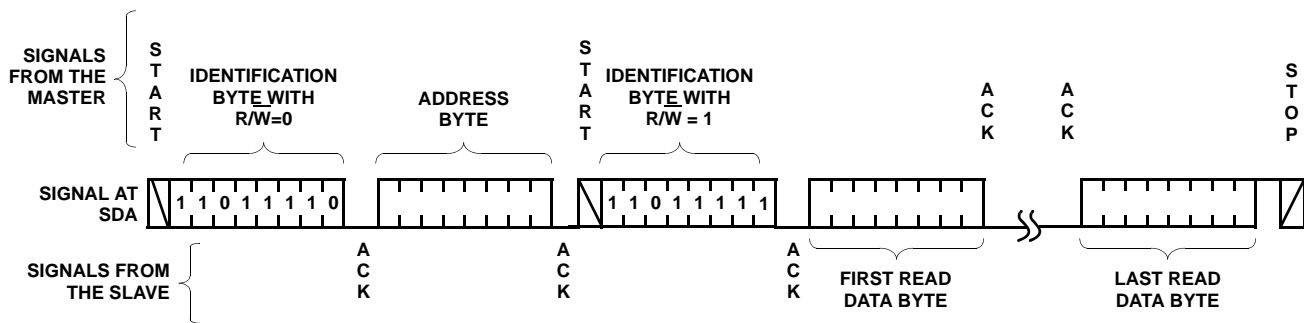

FIGURE 10. READ SEQUENCE (CSR SLAVE ADDRESS SHOWN)

Application Section

Oscillator Crystal Requirements

The ISL12032 uses a standard 32.768kHz crystal. Either through hole or surface mount crystals can be used. Table 28 lists some recommended surface mount crystals and the parameters of each. This list is not exhaustive and other surface mount devices can be used with the ISL12032 if their specifications are very similar to the devices listed. The crystal should have a required parallel load capacitance of 12.5pF and an equivalent series resistance of less than 50k Ω . The crystal's temperature range specification should match the application. Many crystals are rated for -10°C to +60°C (especially through hole and tuning fork types), so an appropriate crystal should be selected if extended temperature range is required.

TABLE 28. SUGGESTED SURFACE MOUNT CRYSTALS

MANUFACTURER	PART NUMBER
Citizen	CM200S
Epson	MC-405, MC-406
Raltron	RSM-200S
SaRonix	32S12
Ecliptek	ECPSM29T-32.768K
ECS	ECX-306
Fox	FSM-327

Layout Considerations

The crystal input at X1 has a very high impedance, and oscillator circuits operating at low frequencies (such as 32.768kHz) are known to pick up noise very easily if layout precautions are not followed. Most instances of erratic clocking or large accuracy errors can be traced to the susceptibility of the oscillator circuit to interference from adjacent high speed clock or data lines. Careful layout of the RTC circuit will avoid noise pickup and ensure accurate clocking.

Two main precautions for crystal PC board layout should be followed:

1. Do not run the serial bus lines or any high speed logic lines in the vicinity of the crystal. These logic level lines can induce noise in the oscillator circuit to cause misclocking.
2. Add a ground trace around the crystal with one end terminated at the chip ground. This will provide termination for emitted noise in the vicinity of the RTC device.

In addition, it is a good idea to avoid a ground plane under the X1 and X2 pins and the crystal, as this will affect the load capacitance and therefore the oscillator accuracy of the circuit. If the F_{OUT} pin is used as a clock, it should be routed away from the RTC device as well. The traces for the V_{BAT}

and V_{DD} pins can be treated as a ground, and should be routed around the crystal.

AC Input Circuits

The AC input ideally will have a 2.5V_{P-P} sine wave at the input, so this is the target for any signal conditioning circuitry for the 50/60Hz waveform. Note that the peak-to-peak amplitude can range from 1V_{P-P} up to V_{DD}, although it is best to keep the max signal level just below V_{DD}. The AC input provides DC offset so AC coupling with a series capacitor is advised.

If the AC power supply has a transformer, the secondary output can be used for clocking with a resistor divider and series AC coupling capacitor. A sample circuit is shown in Figure 12. Values for R₁/R₂ are chosen depending on the peak-to-peak range on the secondary voltage in order to match the input of the ISL12032. C_{IN} can be sized to pass up to 300Hz or so, and in most cases, 0.47 μ F should be the selected value for a \pm 20% tolerance device.

The AC input to the IS12032 can be damaged if subjected to a normal AC waveform when V_{DD} is powered down. This can happen in circuits where there is a local LDO or power switch for placing circuitry in standby, while the AC main is still switched ON. Figure 11 shows a modified version of the Figure 12 circuit, which uses an emitter follower to essentially turn off the AC input waveform if the V_{DD} supply goes down.

Using the ISL12032 with No AC Input

Some applications may need all the features of the ISL12032 but do not have access to the power line AC clock, or do not need the accuracy provided by that clock. In these cases there is no problem using the crystal oscillator as the primary clock source for the device.

The user must simply set the ACENB bit in register 13h to "1", which disables the AC input pin and forces the device to use the crystal oscillator exclusively for the RTC and F_{OUT} clock source. Setting this bit to "1" also will cause the ACRDY bit in the SRAC register to be set to "1", indicating that there can be no fault with the AC input clock since it is not used.

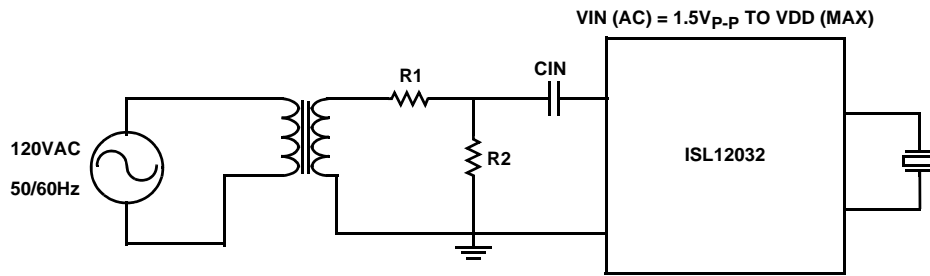

FIGURE 11. AC INPUT USING A TRANSFORMER SECONDARY

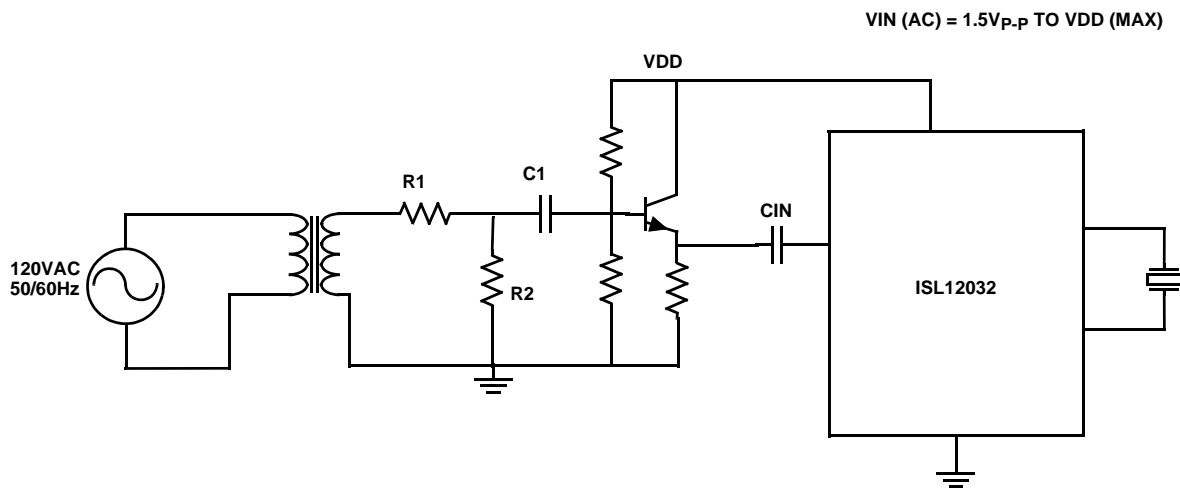
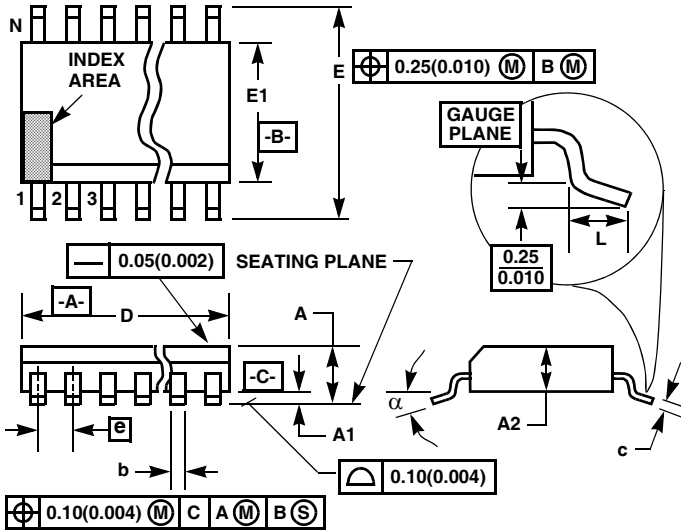

FIGURE 12. USING THE V_{DD} SUPPLY TO GATE THE AC INPUT

Thin Shrink Small Outline Plastic Packages (TSSOP)



M14.173
14 LEAD THIN SHRINK SMALL OUTLINE PLASTIC PACKAGE

SYMBOL	INCHES		MILLIMETERS		NOTES
	MIN	MAX	MIN	MAX	
A	-	0.047	-	1.20	-
A1	0.002	0.006	0.05	0.15	-
A2	0.031	0.041	0.80	1.05	-
b	0.0075	0.0118	0.19	0.30	9
c	0.0035	0.0079	0.09	0.20	-
D	0.195	0.199	4.95	5.05	3
E1	0.169	0.177	4.30	4.50	4
e	0.026 BSC		0.65 BSC		-
E	0.246	0.256	6.25	6.50	-
L	0.0177	0.0295	0.45	0.75	6
N	14		14		7
α	0°	8°	0°	8°	-

NOTES:

1. These package dimensions are within allowable dimensions of JEDEC MO-153-AC, Issue E.
2. Dimensioning and tolerancing per ANSI Y14.5M-1982.
3. Dimension "D" does not include mold flash, protrusions or gate burrs. Mold flash, protrusion and gate burrs shall not exceed 0.15mm (0.006 inch) per side.
4. Dimension "E1" does not include interlead flash or protrusions. Interlead flash and protrusions shall not exceed 0.15mm (0.006 inch) per side.
5. The chamfer on the body is optional. If it is not present, a visual index feature must be located within the crosshatched area.
6. "L" is the length of terminal for soldering to a substrate.
7. "N" is the number of terminal positions.
8. Terminal numbers are shown for reference only.
9. Dimension "b" does not include dambar protrusion. Allowable dambar protrusion shall be 0.08mm (0.003 inch) total in excess of "b" dimension at maximum material condition. Minimum space between protrusion and adjacent lead is 0.07mm (0.0027 inch).
10. Controlling dimension: MILLIMETER. Converted inch dimensions are not necessarily exact. (Angles in degrees)

Rev. 2 4/06

All Intersil U.S. products are manufactured, assembled and tested utilizing ISO9000 quality systems. Intersil Corporation's quality certifications can be viewed at www.intersil.com/design/quality

Intersil products are sold by description only. Intersil Corporation reserves the right to make changes in circuit design, software and/or specifications at any time without notice. Accordingly, the reader is cautioned to verify that data sheets are current before placing orders. Information furnished by Intersil is believed to be accurate and reliable. However, no responsibility is assumed by Intersil or its subsidiaries for its use; nor for any infringements of patents or other rights of third parties which may result from its use. No license is granted by implication or otherwise under any patent or patent rights of Intersil or its subsidiaries.

For information regarding Intersil Corporation and its products, see www.intersil.com