

+1.8V to +6.5V, Sub-Ohm, Dual SPDT Analog Switch with Negative Signal Capability

The Intersil ISL54059 device is a low ON-resistance, low voltage, bidirectional, dual single-pole/double-throw (SPDT) analog switch. It is designed to operate from a single +1.8V to +6.5V supply and pass signals that swing up to 6.5V below the positive supply rail. Targeted applications include battery powered equipment that benefit from low r_{ON} (0.56Ω), low power consumption (8nA) and fast switching speeds ($t_{ON} = 55ns$, $t_{OFF} = 18ns$). The digital inputs are 1.8V logic-compatible up to a +3V supply. The ISL54059 is offered in a small form factor package, alleviating board space limitations. It is available in a tiny 10 Ld 1.8x1.4mm μ TQFN or 10 Ld 3x3mm TDFN package.

The ISL54059 is a committed dual single-pole/double-throw (SPDT) that consist of two normally open (NO) and two normally closed (NC) switches with independent logic control. This configuration can be used as a dual 2-to-1 multiplexer.

TABLE 1. FEATURES AT A GLANCE

	ISL54059
Number of Switches	2
SW	SPDT or 2-to-1 MUX
4.3V r_{ON}	0.65Ω
4.3V t_{ON}/t_{OFF}	43ns/23ns
2.7V r_{ON}	0.9Ω
2.7V t_{ON}/t_{OFF}	55ns/18ns
1.8V r_{ON}	1.8Ω
1.8V t_{ON}/t_{OFF}	145ns/28ns
Packages	10 Ld μ TQFN, 10 Ld TDFN

Features

- Pb-Free (RoHS Compliant)
- Negative Signal Capability
- ON-Resistance (r_{ON})
 - $V_+ = +4.5V$ 0.52Ω
 - $V_+ = +4.3V$ 0.65Ω
 - $V_+ = +2.7V$ 0.9Ω
 - $V_+ = +1.8V$ 1.8Ω
- r_{ON} Matching Between Channels 10mΩ
- r_{ON} Flatness Across Signal Range 0.33Ω
- Low THD+N @ 32Ω Load 0.02%
- Single Supply Operation +1.8V to +6.5V
- Low Power Consumption (P_D) 8nA
- Fast Switching Action ($V_+ = +4.3V$)
 - t_{ON} 43ns
 - t_{OFF} 23ns
- ESD HBM Rating >6kV
- Guaranteed Break-before-Make
- 1.8V Logic Compatible (+3V supply)
- Low I+ Current when V_{INH} is not at the V_+ Rail
- Available in 10 Ld μ TQFN 1.8x1.4mm and 10 Ld 3x3mm TDFN

Applications

- Audio and Video Switching
- Battery powered, Handheld, and Portable Equipment
 - MP3 and Multimedia Players
 - Cellular/mobile Phones
 - Pagers
 - Laptops, Notebooks, Palmtops
- Portable Test and Measurement
- Medical Equipment

Related Literature

- Technical Brief TB363 "Guidelines for Handling and Processing Moisture Sensitive Surface Mount Devices (SMDs)"
- Application Note AN557 "Recommended Test Procedures for Analog Switches"

Pinout (Note 1)

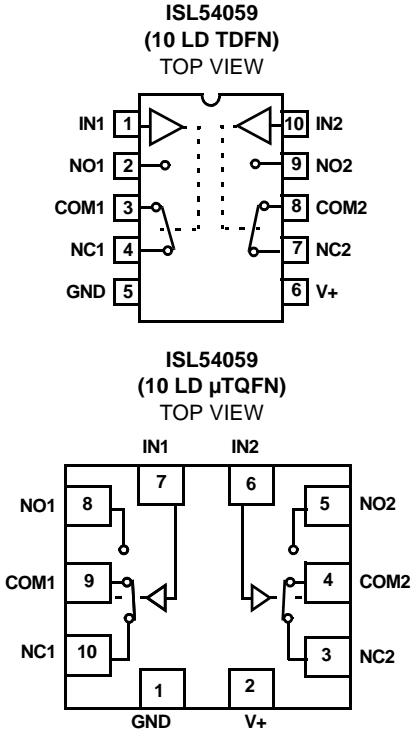

NOTE:

1. Switches Shown for INx = Logic "0".

Truth Table

IN1	IN2	NC1	NO1	NC2	NO2
0	0	ON	OFF	ON	OFF
0	1	ON	OFF	OFF	ON
1	0	OFF	ON	ON	OFF
1	1	OFF	ON	OFF	ON

NOTE: Logic "0" ≤0.5V. Logic "1" ≥1.4V with a 3V supply.

Pin Descriptions

PIN	FUNCTION
V+	IC Power Supply (+1.8V to +6.5V). Decouple V+ to ground by placing a 0.1μF capacitor at the V+ and GND supply lines as near as the IC as possible.
GND	Ground Connection
INx	Digital Control Input
COM	Analog Switch Common Pin
NOx	Analog Switch Normally Open Pin
NCx	Analog Switch Normally Closed Pin

Ordering Information

PART NUMBER	PART MARKING	TEMP. RANGE (°C)	PACKAGE (Pb-Free)	PKG. DWG. #
ISL54059IRTZ (Note 3)	4059	-40 to +85	10 Ld 3x3 TDFN	L10.3x3A
ISL54059IRTZ-T (Notes 2, 3)	4059	-40 to +85	10 Ld 3x3 TDFN (Tape and Reel)	L10.3x3A
ISL54059IRUZ-T (Notes 2, 4)	7	-40 to +85	10 Ld Thin μTQFN (Tape and Reel)	L10.1.8x1.4A

NOTES:

2. Please refer to TB347 for details on reel specifications.
3. These Intersil Pb-free plastic packaged products employ special Pb-free material sets, molding compounds/die attach materials, and 100% matte tin plate plus anneal (e3 termination finish, which is RoHS compliant and compatible with both SnPb and Pb-free soldering operations). Intersil Pb-free products are MSL classified at Pb-free peak reflow temperatures that meet or exceed the Pb-free requirements of IPC/JEDEC J STD-020.
4. These Intersil Pb-free plastic packaged products employ special Pb-free material sets; molding compounds/die attach materials and NiPdAu plate - e4 termination finish, which is RoHS compliant and compatible with both SnPb and Pb-free soldering operations. Intersil Pb-free products are MSL classified at Pb-free peak reflow temperatures that meet or exceed the Pb-free requirements of IPC/JEDEC J STD-020.

Absolute Maximum Ratings

V+ to GND	-0.5 to 7.0V
Input Voltages	
NOx, NCx (Note 5)	(V+ - 7V) to ((V+) + 0.5V)
INx (Note 5)	-0.5 to ((V+) + 0.5V)
Output Voltages	
COMx (Note 5)	(V+ - 7V) to ((V+) + 0.5V)
Continuous Current NOx, NCx, or COMx	±300mA
Peak Current NOx, NCx, or COMx (Pulsed 1ms, 10% Duty Cycle, Max)	±500mA
ESD Rating:	
Human Body Model	>6kV
Machine Model	>400V
Charged Device Model	>1.5kV

Thermal Information

Thermal Resistance (Typical)	θ_{JA} (°C/W)	θ_{JC} (°C/W)
10 Ld 3x3 TDFN Package (Notes 6, 8)	52	18
10 Ld μ TQFN Package (Note 7)	154	N/A
Maximum Junction Temperature (Plastic Package)	+150°C	
Maximum Storage Temperature Range	-65°C to +150°C	
Pb-Free Reflow Profile	see link below http://www.intersil.com/pbfree/Pb-FreeReflow.asp	

Operating Conditions

Temperature Range	-40°C to +85°C
Power Supply Range	+1.8V to +6.5V
Analog Signal Range	(V+ - 6.5)V to V+

CAUTION: Do not operate at or near the maximum ratings listed for extended periods of time. Exposure to such conditions may adversely impact product reliability and result in failures not covered by warranty.

NOTES:

- Signals on NC, NO, IN, or COM exceeding V+ or GND by specified amount are clamped by internal diodes. Limit forward diode current to maximum current ratings.
- θ_{JA} is measured in free air with the component mounted on a high effective thermal conductivity test board with "direct attach" features. See Tech Brief TB379.
- θ_{JA} is measured with the component mounted on a high effective thermal conductivity test board in free air. See Tech Brief TB379 for details.
- For θ_{JC} , the "case temp" location is the center of the exposed metal pad on the package underside.

Electrical Specifications - 5V Supply Test Conditions: V+ = +4.5V to +5.5V, GND = 0V, V_{INH} = 2.4V, V_{INL} = 0.8V (Note 9), Unless Otherwise Specified.

PARAMETER	TEST CONDITIONS	TEMP (°C)	MIN (Notes 10, 11)	TYP	MAX (Notes 10, 11)	UNITS
ANALOG SWITCH CHARACTERISTICS						
ON-Resistance, r_{ON}	V+ = 4.5V, I_{COM} = 100mA, V_{NO} or V_{NC} = (V+ - 6.5) to V+ (see Figure 5)	25	-	0.52	-	Ω
		Full	-	0.68	-	Ω
r_{ON} Matching Between Channels, Δr_{ON}	V+ = 4.5V, I_{COM} = 100mA, V_{NO} or V_{NC} = Voltage at max r_{ON} , (Note 13)	25	-	10	-	m Ω
		Full	-	13.1	-	m Ω
r_{ON} Flatness, $R_{FLAT(ON)}$	V+ = 4.5V, I_{COM} = 100mA, V_{NO} or V_{NC} = (V+ - 6.5) to V+, (Note 12)	25	-	0.11	-	Ω
		Full	-	0.14	-	Ω
NO or NC OFF Leakage Current, $I_{NO(OFF)}$ or $I_{NC(OFF)}$	V+ = 5V, V_{COM} = -1.5V, 5V, V_{NO} or V_{NC} = 5V, -1.5V	25	-	-8.13	-	nA
		Full	-	-0.4	-	μ A
COM ON Leakage Current, $I_{COM(ON)}$	V+ = 5V, V_{COM} = -1.5V, 5V, V_{NO} or V_{NC} = Float	25	-	-4.42	-	nA
		Full	-	-0.33	-	μ A
DYNAMIC CHARACTERISTICS						
Turn-ON Time, t_{ON}	V+ = 4.5V, V_{NO} or V_{NC} = 3.0V, R_L = 50 Ω , C_L = 35pF (see Figure 1)	25	-	35	-	ns
		Full	-	50	-	ns
Turn-OFF Time, t_{OFF}	V+ = 4.5V, V_{NO} or V_{NC} = 3.0V, R_L = 50 Ω , C_L = 35pF (see Figure 1)	25	-	16	-	ns
		Full	-	22	-	ns
Break-Before-Make Time Delay, t_D	V+ = 5.5V, V_{NO} or V_{NC} = 3.0V, R_L = 50 Ω , C_L = 35pF (see Figure 3)	Full	-	18	-	ns
Charge Injection, Q	V_G = 0V, R_G = 0 Ω , C_L = 1.0nF (see Figure 2)	25	-	170	-	pC
OFF-Isolation	R_L = 50 Ω , C_L = 5pF, f = 100kHz, V_{COM} = 1V _{RMS} (see Figure 4)	25	-	60	-	dB
Crosstalk (Channel-to-Channel)	R_L = 50 Ω , C_L = 5pF, f = 1MHz, V_{COM} = 1V _{RMS} (see Figure 6)	25	-	-75	-	dB
Total Harmonic Distortion	f = 20Hz to 20kHz, V_{COM} = 0.5V _{P-P} , R_L = 32 Ω	25	-	0.02	-	%
-3dB Bandwidth	V_{COM} = 1V _{RMS} , R_L = 50 Ω , C_L = 5pF	25	-	60	-	MHz

ISL54059

Electrical Specifications - 5V Supply Test Conditions: $V_+ = +4.5V$ to $+5.5V$, $GND = 0V$, $V_{INH} = 2.4V$, $V_{INL} = 0.8V$ (Note 9), Unless Otherwise Specified. **(Continued)**

PARAMETER	TEST CONDITIONS	TEMP (°C)	MIN (Notes 10, 11)	TYP	MAX (Notes 10, 11)	UNITS
NO x or NCx OFF Capacitance, C_{OFF}	$f = 1MHz$ (see Figure 7)	25	-	36	-	pF
COMx ON Capacitance, $C_{COM(ON)}$	$f = 1MHz$ (see Figure 7)	25	-	88	-	pF
POWER SUPPLY CHARACTERISTICS						
Positive Supply Current, I_+	$V_+ = 5.5V$, $V_{IN} = 0V$ or V_+	25	-	0.008	0.1	μA
		Full	-	1.41	-	μA
DIGITAL INPUT CHARACTERISTICS						
Input Voltage Low, V_{INL}		Full	-	-	0.8	V
Input Voltage High, V_{INH}		Full	2.4	-	-	V
Input Current, I_{INH} , I_{INL}	$V_+ = 5.5V$, $V_{IN} = 0V$ or V_+	25	-0.1	-	0.1	μA
		Full	-	0.3	-	μA

Electrical Specifications - 4.3V Supply Test Conditions: $V_+ = +3.9V$ to $+4.5V$, $GND = 0V$, $V_{INH} = 1.6V$, $V_{INL} = 0.5V$ (Note 9), Unless Otherwise Specified.

PARAMETER	TEST CONDITIONS	TEMP (°C)	MIN (Notes 10, 11)	TYP	MAX (Notes 10, 11)	UNITS
ANALOG SWITCH CHARACTERISTICS						
ON-Resistance, r_{ON}	$V_+ = 4.3V$, $I_{COM} = 100mA$, V_{NO} or $V_{NC} = (V_+ - 6.5V)$ to V_+ , (See Figure 5)	25	-	0.65	-	Ω
		Full	-	0.72	-	Ω
r_{ON} Matching Between Channels, Δr_{ON}	$V_+ = 4.3V$, $I_{COM} = 100mA$, V_{NO} or $V_{NC} =$ Voltage at max r_{ON} , (Note 12)	25	-	10	-	$m\Omega$
		Full	-	15	-	$m\Omega$
r_{ON} Flatness, $R_{FLAT(ON)}$	$V_+ = 4.3V$, $I_{COM} = 100mA$, V_{NO} or $V_{NC} = (V_+ - 6.5V)$ to V_+ , (Note 13)	25	-	0.1	-	Ω
		Full	-	0.14	-	Ω
NO or NC OFF Leakage Current, $I_{NO(OFF)}$ or $I_{NC(OFF)}$	$V_+ = 4.3V$, $V_{COM} = -1.2V$, $4.3V$, V_{NO} or $V_{NC} = 4.3V$, $-1.2V$	25	-0.1	-	0.1	μA
		Full	-1	-0.33	1	μA
COM ON Leakage Current, $I_{COM(ON)}$	$V_+ = 4.3V$, $V_{COM} = -1.2V$, $4.3V$, V_{NO} or $V_{NC} =$ Float	25	-0.1	-	0.1	μA
		Full	-1	-0.33	1	μA
DYNAMIC CHARACTERISTICS						
Turn-ON Time, t_{ON}	$V_+ = 3.9V$, V_{NO} or $V_{NC} = 3.0V$, $R_L = 50\Omega$, $C_L = 35pF$ (see Figure 1)	25	-	43	-	ns
		Full	-	50	-	ns
Turn-OFF Time, t_{OFF}	$V_+ = 3.9V$, V_{NO} or $V_{NC} = 3.0V$, $R_L = 50\Omega$, $C_L = 35pF$ (see Figure 1)	25	-	23.1	-	ns
		Full	-	23.2	-	ns
Break-Before-Make Time Delay, t_D	$V_+ = 4.5V$, V_{NO} or $V_{NC} = 3.0V$, $R_L = 50\Omega$, $C_L = 35pF$ (see Figure 3)	Full	-	22	-	ns
Charge Injection, Q	$C_L = 1.0nF$, $V_G = 0V$, $R_G = 0\Omega$ (see Figure 2)	25	-	200	-	pC
OFF-Isolation	$R_L = 50\Omega$, $C_L = 5pF$, $f = 100kHz$, $V_{COM} = 1V_{RMS}$ (see Figure 4)	25	-	60	-	dB
Crosstalk (Channel-to-Channel)	$R_L = 50\Omega$, $C_L = 5pF$, $f = 1MHz$, $V_{COM} = 1V_{RMS}$ (see Figure 6)	25	-	-75	-	dB
Total Harmonic Distortion	$f = 20Hz$ to $20kHz$, $V_{COM} = 2V_{P-P}$, $R_L = 32\Omega$	25	-	0.04	-	%
NOx or NCx OFF Capacitance, C_{OFF}	$f = 1MHz$ (see Figure 7)	25	-	36	-	pF

ISL54059

Electrical Specifications - 4.3V Supply Test Conditions: $V_+ = +3.9V$ to $+4.5V$, $GND = 0V$, $V_{INH} = 1.6V$, $V_{INL} = 0.5V$ (Note 9), Unless Otherwise Specified. **(Continued)**

PARAMETER	TEST CONDITIONS	TEMP (°C)	MIN (Notes 10, 11)	TYP	MAX (Notes 10, 11)	UNITS
COMx ON Capacitance, $C_{COM(ON)}$	$f = 1MHz$ (see Figure 7)	25	-	88	-	pF
POWER SUPPLY CHARACTERISTICS						
Positive Supply Current, I_+	$V_+ = +4.5V$, $V_{IN} = 0V$ or V_+	25	-	0.003	0.1	μA
		Full	-	0.9	-	μA
Positive Supply Current, I_+	$V_+ = +4.2V$, $V_{IN} = 2.85V$	25	-	0.78	12	μA
DIGITAL INPUT CHARACTERISTICS						
Input Voltage Low, V_{INL}		Full	-	-	0.5	V
Input Voltage High, V_{INH}		Full	1.6	-	-	V
Input Current, I_{INH} , I_{INL}	$V_+ = 4.5V$, $V_{IN} = 0V$ or V_+	25	-0.5	-	0.5	μA
		Full	-	0.2	-	μA

Electrical Specifications - 3V Supply Test Conditions: $V_+ = +2.7V$ to $+3.3V$, $GND = 0V$, $V_{INH} = 1.4V$, $V_{INL} = 0.5V$ (Note 9), Unless Otherwise Specified.

PARAMETER	TEST CONDITIONS	TEMP (°C)	MIN (Notes 10, 11)	TYP	MAX (Notes 10, 11)	UNITS
ANALOG SWITCH CHARACTERISTICS						
ON-Resistance, r_{ON}	$V_+ = 2.7V$, $I_{COM} = 100mA$, V_{NO} or $V_{NC} = (V_+ - 6.5V)$ to V_+ (see Figure 5)	25	-	0.9	-	Ω
		Full	-	0.96	-	Ω
r_{ON} Matching Between Channels, Δr_{ON}	$V_+ = 2.7V$, $I_{COM} = 100mA$, V_{NO} or $V_{NC} =$ Voltage at max r_{ON} (Note 13)	25	-	10	-	$m\Omega$
		Full	-	17	-	$m\Omega$
r_{ON} Flatness, $R_{FLAT(ON)}$	$V_+ = 2.7V$, $I_{COM} = 100mA$, V_{NO} or $V_{NC} = (V_+ - 6.5V)$ to V_+ (Note 12, 14)	25	-	0.33	0.5	Ω
		Full	-	0.35	0.55	Ω
DYNAMIC CHARACTERISTICS						
Turn-ON Time, t_{ON}	$V_+ = 2.7V$, V_{NO} or $V_{NC} = 1.5V$, $R_L = 50\Omega$, $C_L = 35pF$ (see Figure 1)	25	-	55	-	ns
		Full	-	82	-	ns
Turn-OFF Time, t_{OFF}	$V_+ = 2.7V$, V_{NO} or $V_{NC} = 1.5V$, $R_L = 50\Omega$, $C_L = 35pF$ (see Figure 1)	25	-	18	-	ns
		Full	-	24	-	ns
Break-Before-Make Time Delay, t_D	$V_+ = 3.3V$, V_{NO} or $V_{NC} = 1.5V$, $R_L = 50\Omega$, $C_L = 35pF$ (see Figure 3)	Full	-	30	-	ns
Charge Injection, Q	$C_L = 1.0nF$, $V_G = 0V$, $R_G = 0\Omega$ (see Figure 2)	25	-	150	-	pC
OFF-Isolation	$R_L = 50\Omega$, $C_L = 5pF$, $f = 100kHz$, $V_{COM} = 1V_{RMS}$ (see Figure 4)	25	-	60	-	dB
Crosstalk (Channel-to-Channel)	$R_L = 50\Omega$, $C_L = 5pF$, $f = 1MHz$, $V_{COM} = 1V_{RMS}$ (see Figure 6)	25	-	-75	-	dB
Total Harmonic Distortion	$f = 20Hz$ to $20kHz$, $V_{COM} = 0.5V_{P-P}$, $R_L = 32\Omega$	25	-	0.04	-	%
NOx or NCx OFF Capacitance, C_{OFF}	$f = 1MHz$ (see Figure 7)	25	-	36	-	pF
COMx ON Capacitance, $C_{COM(ON)}$	$f = 1MHz$ (see Figure 7)	25	-	88	-	pF
DIGITAL INPUT CHARACTERISTICS						
Input Voltage Low, V_{INL}		25	-	-	0.5	V
Input Voltage High, V_{INH}		25	1.4	-	-	V
Input Current, I_{INH} , I_{INL}	$V_+ = 3.3V$, $V_{IN} = 0V$ or V_+	25	-0.5	-	0.5	μA
		Full	-	0.2	-	μA

ISL54059

Electrical Specifications - 1.8V Supply

Test Conditions: $V_+ = +1.8V$, $GND = 0V$, $V_{INH} = 1.0V$, $V_{INL} = 0.4V$ (Note 9), Unless Otherwise Specified.

PARAMETER	TEST CONDITIONS	TEMP (°C)	MIN (Notes 10, 11)	TYP	MAX (Notes 10, 11)	UNITS
ANALOG SWITCH CHARACTERISTICS						
ON-Resistance, r_{ON}	$V_+ = 1.8V$, $I_{COM} = 100mA$, V_{NO} or $V_{NC} = (V_+ - 6.5V)$ to V_+ , (see Figure 5)	25	-	1.87	-	Ω
		Full	-	1.97	-	Ω
r_{ON} Matching Between Channels, Δr_{ON}	$V_+ = 1.8V$, $I_{COM} = 100mA$, V_{NO} or $V_{NC} =$ Voltage at max r_{ON} (Note 13)	25	-	16	-	$m\Omega$
		Full	-	30	-	$m\Omega$
r_{ON} Flatness, $R_{FLAT(ON)}$	$V_+ = 1.8V$, $I_{COM} = 100mA$, V_{NO} or $V_{NC} = (V_+ - 6.5V)$ to V_+ (Notes 12)	25	-	1.34	-	Ω
		Full	-	1.43	-	Ω
DYNAMIC CHARACTERISTICS						
Turn-ON Time, t_{ON}	$V_+ = 1.8V$, V_{NO} or $V_{NC} = 1.8V$, $R_L = 50\Omega$, $C_L = 35pF$ (see Figure 1)	25	-	145	-	ns
		Full	-	150	-	ns
Turn-OFF Time, t_{OFF}	$V_+ = 1.8V$, V_{NO} or $V_{NC} = 1.8V$, $R_L = 50\Omega$, $C_L = 35pF$ (see Figure 1)	25	-	20	-	ns
		Full	-	22	-	ns
Break-Before-Make Time Delay, t_D	$V_+ = 1.8V$, V_{NO} or $V_{NC} = 1.8V$, $R_L = 50\Omega$, $C_L = 35pF$ (see Figure 3)	Full	-	130	-	ns
Charge Injection, Q	$C_L = 1.0nF$, $V_G = 0V$, $R_G = 0\Omega$ (see Figure 2)	25	-	40	-	pC
NOx or NCx OFF Capacitance, C_{OFF}	$f = 1MHz$ (see Figure 7)	25	-	36	-	pF
COMx ON Capacitance, $C_{COM(ON)}$	$f = 1MHz$ (see Figure 7)	25	-	88	-	pF
DIGITAL INPUT CHARACTERISTICS						
Input Voltage Low, V_{INL}		25	-	-	0.4	V
Input Voltage High, V_{INH}		25	1.0	-	-	V
Input Current, I_{INH} , I_{INL}	$V_+ = 2.0V$, $V_{IN} = 0V$ or V_+	25	-0.5	-	0.5	μA
Input Current, I_{INH} , I_{INL}	$V_+ = 2.0V$, $V_{IN} = 0V$ or V_+	Full	-	0.19	-	μA

NOTES:

- V_{IN} = input voltage to perform proper function.
- The algebraic convention, whereby the most negative value is a minimum and the most positive a maximum, is used in this data sheet.
- Parameters with MIN and/or MAX limits are 100% tested at +25°C, unless otherwise specified. Temperature limits established by characterization and are not production tested.
- Flatness is defined as the difference between maximum and minimum value of on-resistance over the specified analog signal range.
- r_{ON} matching between channels is calculated by subtracting the channel with the highest max r_{ON} value from the channel with lowest max r_{ON} value, between NC1 and NC2 or between NO1 and NO2.
- Limits established by characterization and are not production tested.

Test Circuits and Waveforms

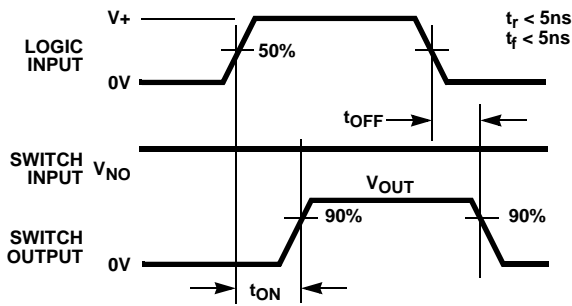

Logic input waveform is inverted for switches that have the opposite logic sense.

FIGURE 1A. MEASUREMENT POINTS

FIGURE 1. SWITCHING TIMES

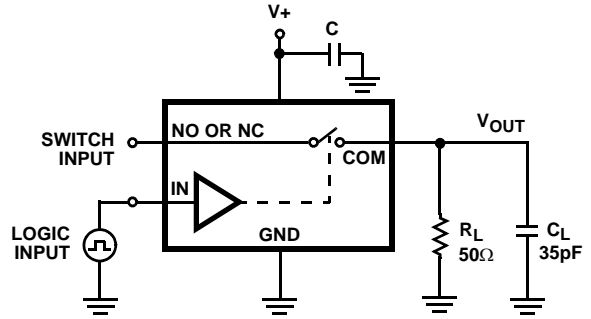

Repeat test for all switches. C_L includes fixture and stray capacitance.

$$V_{OUT} = V_{(NO \text{ or } NC)} \frac{R_L}{R_L + r_{ON}}$$

FIGURE 1B. TEST CIRCUIT

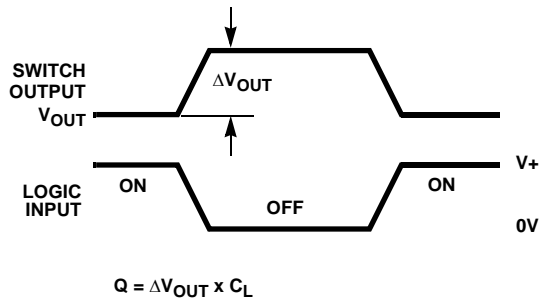
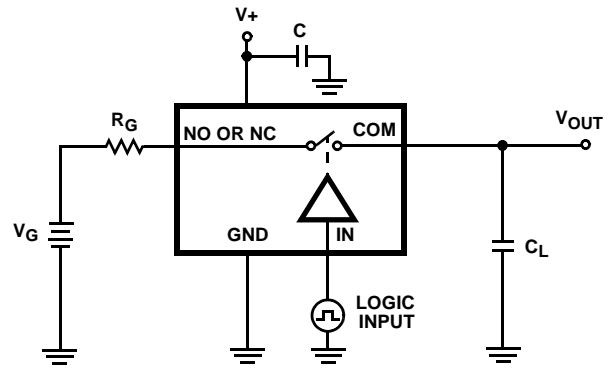

FIGURE 2A. MEASUREMENT POINTS

FIGURE 2. CHARGE INJECTION



Repeat test for all switches.

FIGURE 2B. TEST CIRCUIT

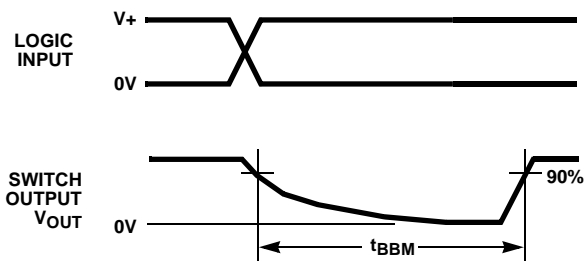
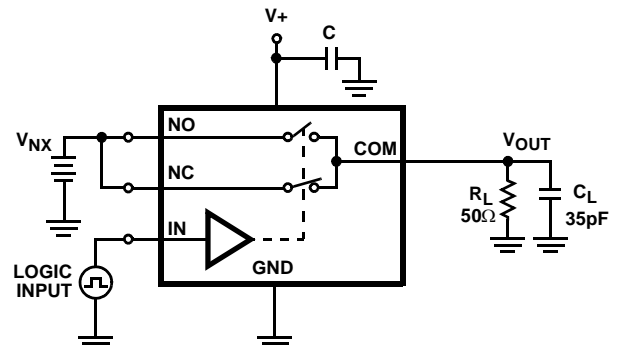

FIGURE 3A. MEASUREMENT POINTS

FIGURE 3. BREAK-BEFORE-MAKE TIME



Repeat test for all switches. C_L includes fixture and stray capacitance.

FIGURE 3B. TEST CIRCUIT

Test Circuits and Waveforms (Continued)

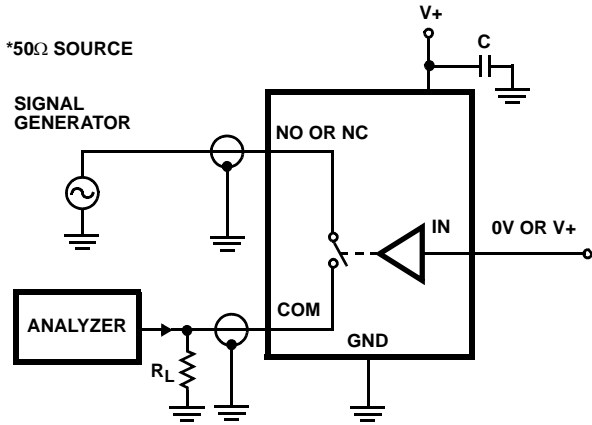

Signal direction through switch is reversed, worst case values are recorded. Repeat test for all switches.

FIGURE 4. OFF-ISOLATION TEST CIRCUIT

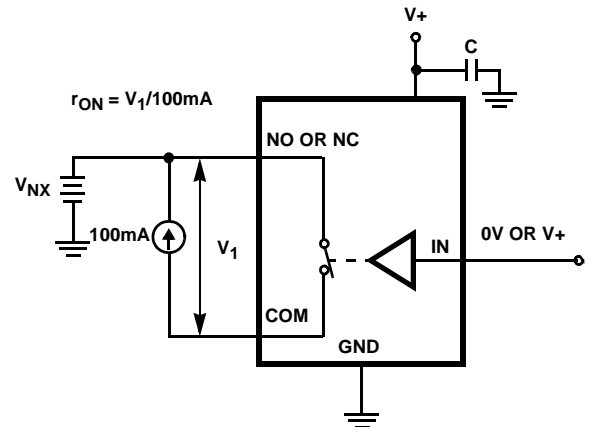

Repeat test for all switches.

FIGURE 5. r_{ON} TEST CIRCUIT

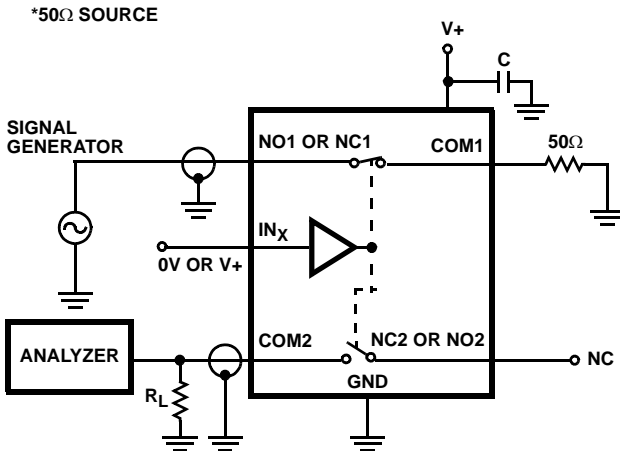

Signal direction through switch is reversed, worst case values are recorded. Repeat test for all switches.

FIGURE 6. CROSSTALK TEST CIRCUIT

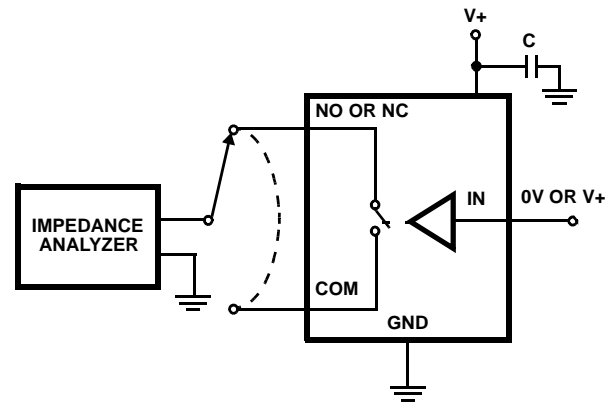

COM is connected to NO or NC during ON capacitance measurement.

FIGURE 7. CAPACITANCE TEST CIRCUIT

Detailed Description

The ISL54059 is a bi-directional, dual single pole-double throw (SPDT) analog switch that offers precise switching from a single 1.8V to 6.5V supply with low ON-resistance (0.83Ω) and high speed operation ($t_{ON} = 55\text{ns}$, $t_{OFF} = 18\text{ns}$). The device is especially well suited for portable battery powered equipment due to its low operating supply voltage (1.8V), low power consumption (8nA), and a tiny 1.8x1.4mm μTQFN package or a 3x3mm TDFN package. The low ON-resistance and r_{ON} flatness provide very low insertion loss and signal distortion for applications that require signal switching with minimal interference by the switch.

Supply Sequencing and Overvoltage Protection

With any CMOS device, proper power supply sequencing is required to protect the device from excessive input currents which might permanently damage the IC. The ISL54059

contains ESD protection diodes on each pin of the IC (see Figure 8). These diodes connect to either a +Ring or -Ring for ESD protection. To prevent forward biasing the ESD diodes to the +Ring, $V+$ must be applied before any input signals, and the input signal voltages must remain between recommended operating range.

If these conditions cannot be guaranteed, then precautions must be implemented to prohibit the current and voltage at the logic pin and signal pins from exceeding the maximum ratings of the switch. The following two methods can be used to provided additional protection to limit the current in the event that the voltage at a logic pin or switch terminal goes above the $V+$ rail.

Logic inputs can be protected by adding a $1\text{k}\Omega$ resistor in series with the logic input (see Figure 8). The resistor limits

the input current below the threshold that produces permanent damage.

This method is not acceptable for the signal path inputs. Adding a series resistor to the switch input defeats the purpose of using a low r_{ON} switch. Connecting external Schottky diodes to the signal pins will shunt the fault current to the V_+ supply instead of through the internal ESD diodes therefore protecting the switch. These Schottky diodes must be sized to handle the expected fault current.

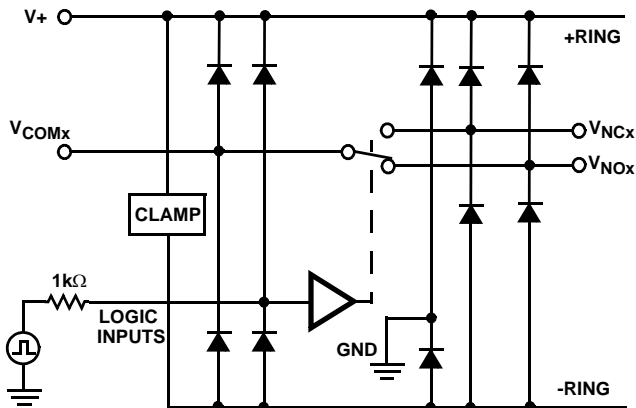

FIGURE 8. OVERVOLTAGE PROTECTION

Power-Supply Considerations

The ISL54059 construction is typical of most single supply CMOS analog switches, in that they have two supply pins: V_+ and GND. V_+ and GND drive the internal CMOS switches and set their analog voltage limits. Unlike switches with a 5.5V maximum supply voltage, the ISL54059's 6.5V maximum supply voltage provides plenty of head room for the 10% tolerance of 5.5V supplies due to overshoot and noise spikes.

The minimum recommended supply voltage is 1.8V. It is important to note that the input signal range, switching times, and ON-resistance degrade at lower supply voltages. Refer to the "Electrical Specifications" tables, beginning on page 3, and "Typical Performance Curves", beginning on page 10, for details.

V_+ and GND also power the internal logic and level shifters. The level shifters convert the input logic levels to V_+ and GND signals levels to drive the analog switch gate terminals. A high frequency decoupling capacitor placed as close to the V_+ and GND pin as possible is recommended for proper operation of the switch. A value of 0.1 μ F is highly recommended.

Negative Signal Capability

The ISL54059 contains circuitry that allows the analog input signal to swing below ground. The device has an analog signal range of 6.5V below V_+ up to the V_+ rail (see Figure 14) while maintaining low r_{ON} performance. For example, if $V_+ = 5V$, then the analog input signal range is

from -1.5V to +5V. If $V_+ = 2.7V$ then the range is from -3.8V to +2.7V.

Logic-Level Thresholds

This switch family is 1.8V CMOS compatible (0.45V V_{OLMAX} and 1.35V V_{OHMIN}) over a supply range of 1.8V to 3.3V (see Figure 16). At 3.3V the V_{IL} level is 0.5V maximum. This is still below the 1.8V CMOS guaranteed low output maximum level of 0.45V, but noise margin is reduced. At 3.3V the V_{IH} level is 1.4V minimum. While this is above the 1.8V CMOS guaranteed high output minimum of 1.35V, under most operating conditions the switch will recognize this as a valid logic high.

The digital input stages draw supply current whenever the digital input voltage is not at one of the supply rails. Driving the digital input signals from GND to V_+ with a fast transition time minimizes power dissipation. The ISL54059 has been designed to minimize the supply current whenever the digital input voltage is not driven to the supply rails (0V to V_+). For example, driving the device with 2.85V logic high while operating with a 4.2V supply the device draws only 1 μ A of current.

High-Frequency Performance

In 50 Ω systems, the ISL54065 has an ON switch -3dB bandwidth of 60MHz (see Figure 19). The frequency response is very consistent over a wide V_+ range, and for varying analog signal levels.

An OFF switch acts like a capacitor across the open terminals and AC couples higher frequencies, resulting in signal feed-through from a switch's input to its output. Off Isolation is the resistance to this feed-through. Crosstalk indicates the amount of feed-through from one switch channel to another switch channel. Figure 20 details the high Off-Isolation and Crosstalk rejection provided by this part. At 100kHz, Off-Isolation is about 60dB in 50 Ω systems, decreasing approximately 20dB per decade as frequency increases. At 1MHz, Crosstalk is about -75dB in 50 Ω systems, decreasing approximately 20dB per decade as frequency increases.

Leakage Considerations

Reverse ESD protection diodes are internally connected between each analog-signal pin, V_+ and GND. One of these diodes conducts if any analog signal exceeds the recommended analog signal range.

Virtually all the analog switch leakage current comes from the ESD diodes and reversed biased junctions in the switch cell. Although the ESD diodes on a given signal pin are identical and therefore fairly well balanced, they are reverse biased differently. Each is biased to either the +Ring or -Ring and the analog input signal. This means their leakages will vary as the signal varies. The difference in the two diode leakages to the +Ring or -Ring and the reverse biased junctions at the internal switch cell constitutes the analog-signal-path leakage current.

Typical Performance Curves $T_A = +25^\circ\text{C}$, Unless Otherwise Specified

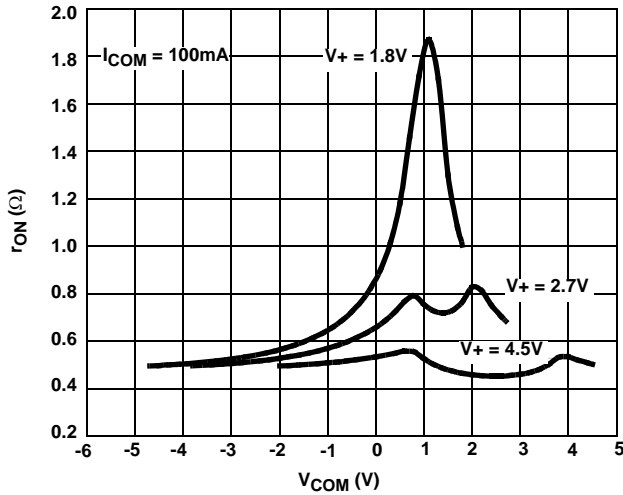

FIGURE 9. ON-RESISTANCE vs SUPPLY VOLTAGE vs SWITCH VOLTAGE

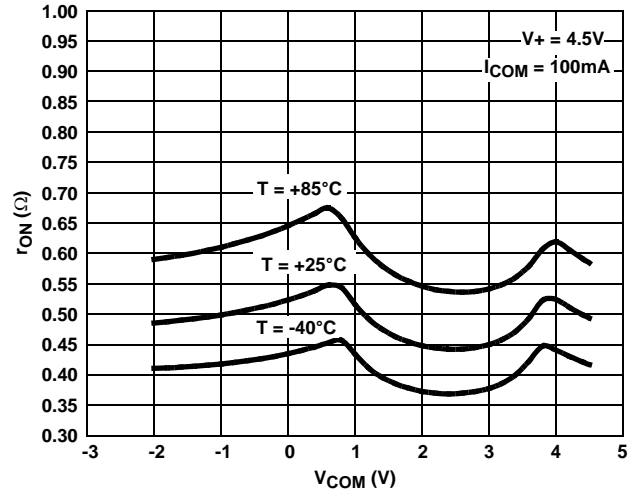

FIGURE 10. ON-RESISTANCE vs SWITCH VOLTAGE

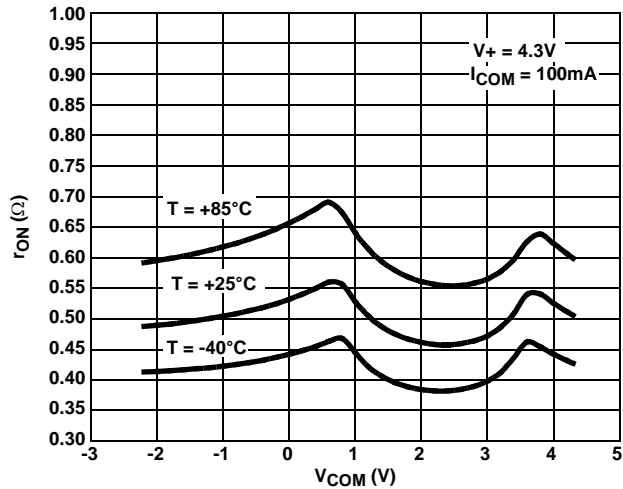

FIGURE 11. ON-RESISTANCE vs SWITCH VOLTAGE

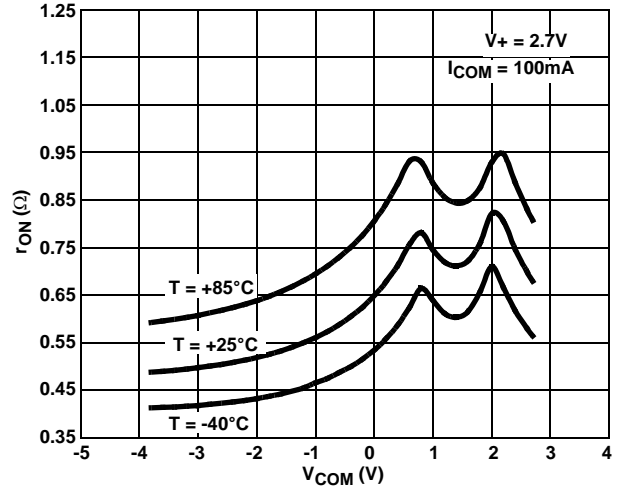

FIGURE 12. ON-RESISTANCE vs SWITCH VOLTAGE

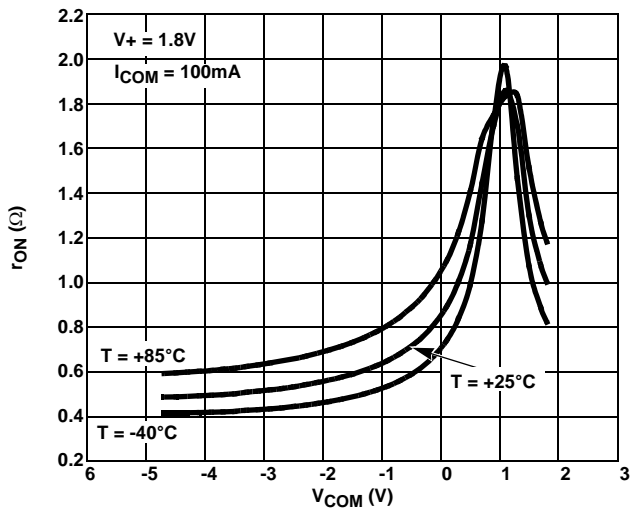

FIGURE 13. ON-RESISTANCE vs SWITCH VOLTAGE

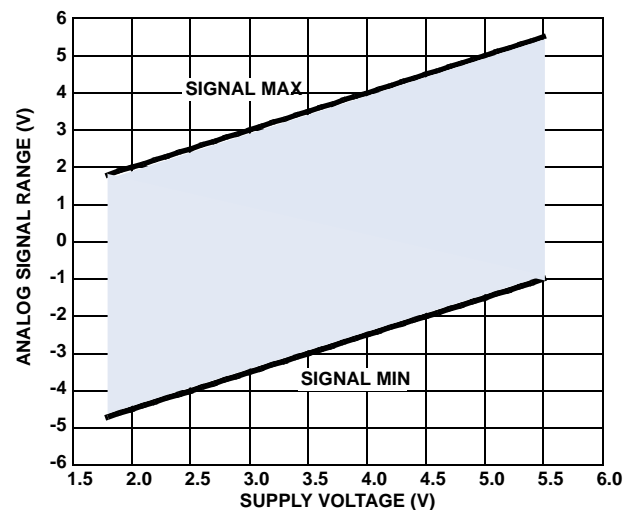

FIGURE 14. ANALOG SIGNAL RANGE vs SUPPLY VOLTAGE

Typical Performance Curves $T_A = +25^\circ\text{C}$, Unless Otherwise Specified (Continued)

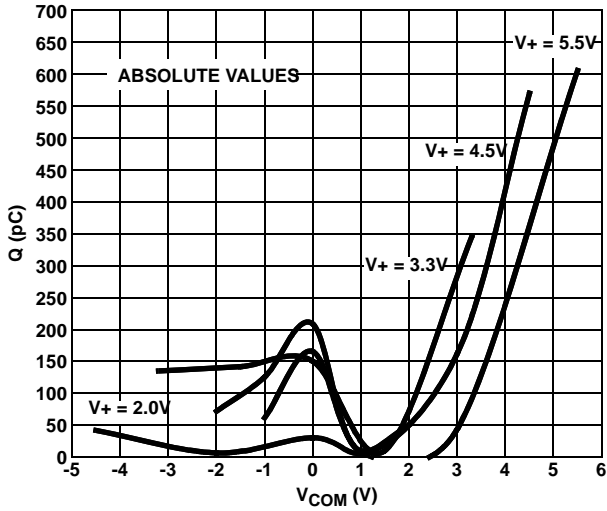

FIGURE 15. CHARGE INJECTION vs SWITCH VOLTAGE

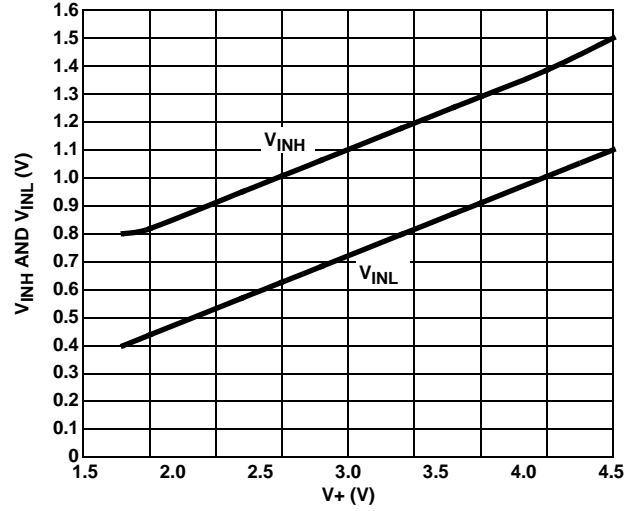

FIGURE 16. DIGITAL SWITCHING POINT vs SUPPLY VOLTAGE

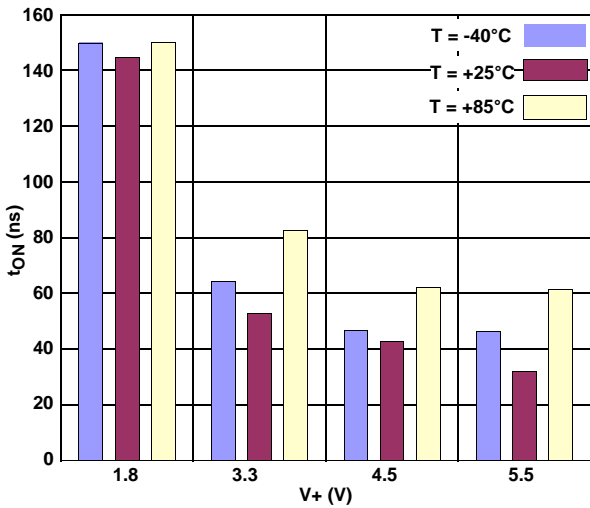

FIGURE 17. TURN - ON TIME vs SUPPLY VOLTAGE

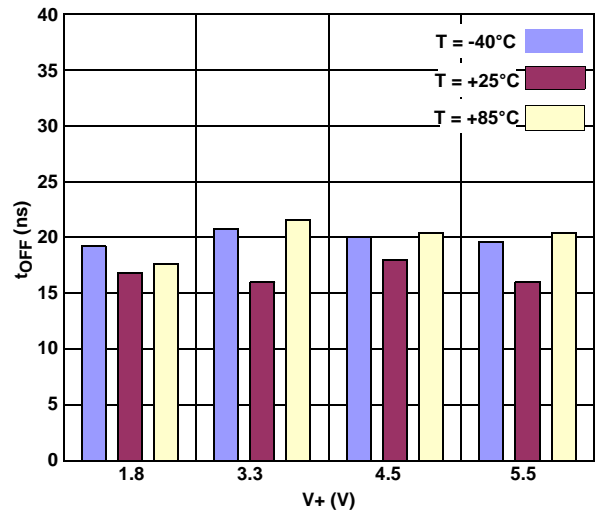

FIGURE 18. TURN - OFF TIME vs SUPPLY VOLTAGE

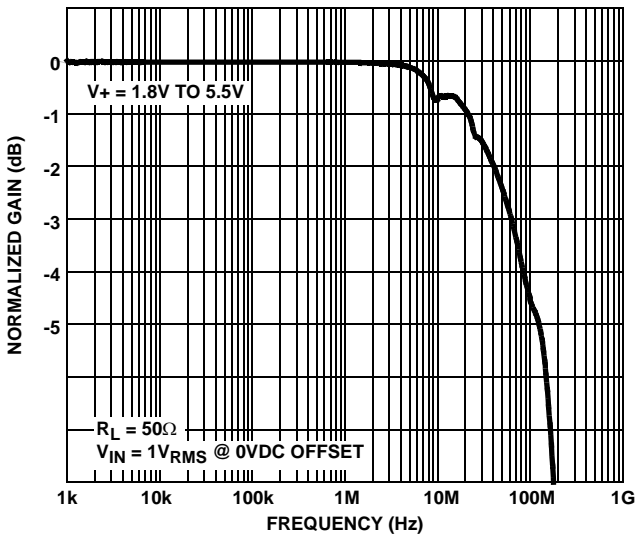

FIGURE 19. FREQUENCY RESPONSE

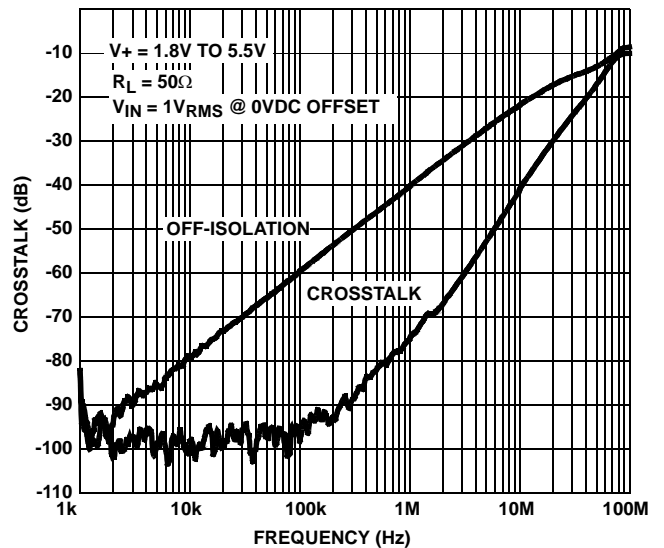

FIGURE 20. CROSSTALK AND OFF ISOLATION

Typical Performance Curves $T_A = +25^\circ\text{C}$, Unless Otherwise Specified (Continued)

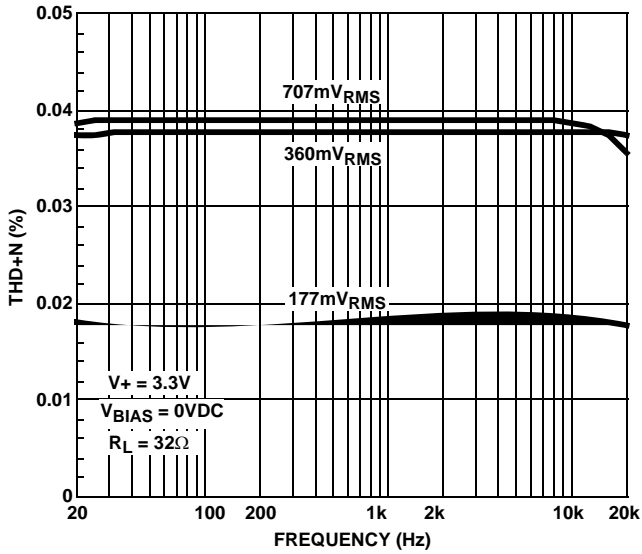

FIGURE 21. TOTAL HARMONIC DISTORTION vs FREQUENCY

Die Characteristics

SUBSTRATE POTENTIAL (POWERED UP):

GND (DFN Paddle Connection: Tie to GND or Float)

TRANSISTOR COUNT:

432

PROCESS:

Submicron CMOS

Thin Dual Flat No-Lead Plastic Package (TDFN)

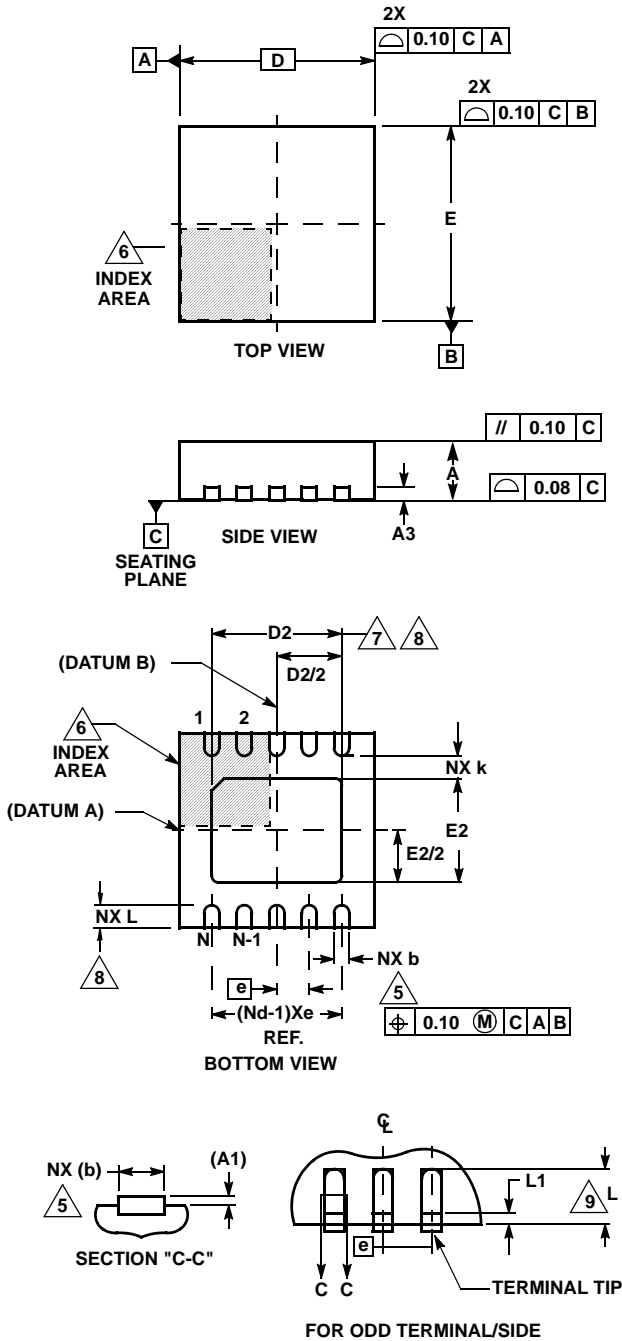

L10.3x3A

10 LEAD THIN DUAL FLAT NO-LEAD PLASTIC PACKAGE

SYMBOL	MILLIMETERS			NOTES
	MIN	NOMINAL	MAX	
A	0.70	0.75	0.80	-
A1	-	-	0.05	-
A3	0.20 REF			-
b	0.20	0.25	0.30	5, 8
D	2.95	3.0	3.05	-
D2	2.25	2.30	2.35	7, 8
E	2.95	3.0	3.05	-
E2	1.45	1.50	1.55	7, 8
e	0.50 BSC			-
k	0.25	-	-	-
L	0.25	0.30	0.35	8
N	10			2
Nd	5			3

Rev. 3 3/06

NOTES:

1. Dimensioning and tolerancing conform to ASME Y14.5-1994.
2. N is the number of terminals.
3. Nd refers to the number of terminals on D.
4. All dimensions are in millimeters. Angles are in degrees.
5. Dimension b applies to the metallized terminal and is measured between 0.15mm and 0.30mm from the terminal tip.
6. The configuration of the pin #1 identifier is optional, but must be located within the zone indicated. The pin #1 identifier may be either a mold or mark feature.
7. Dimensions D2 and E2 are for the exposed pads which provide improved electrical and thermal performance.
8. Nominal dimensions are provided to assist with PCB Land Pattern Design efforts, see Intersil Technical Brief TB389.
9. Compliant to JEDEC MO-229-WEED-3 except for D2 dimensions.

Ultra Thin Quad Flat No-Lead Plastic Package (UTQFN)

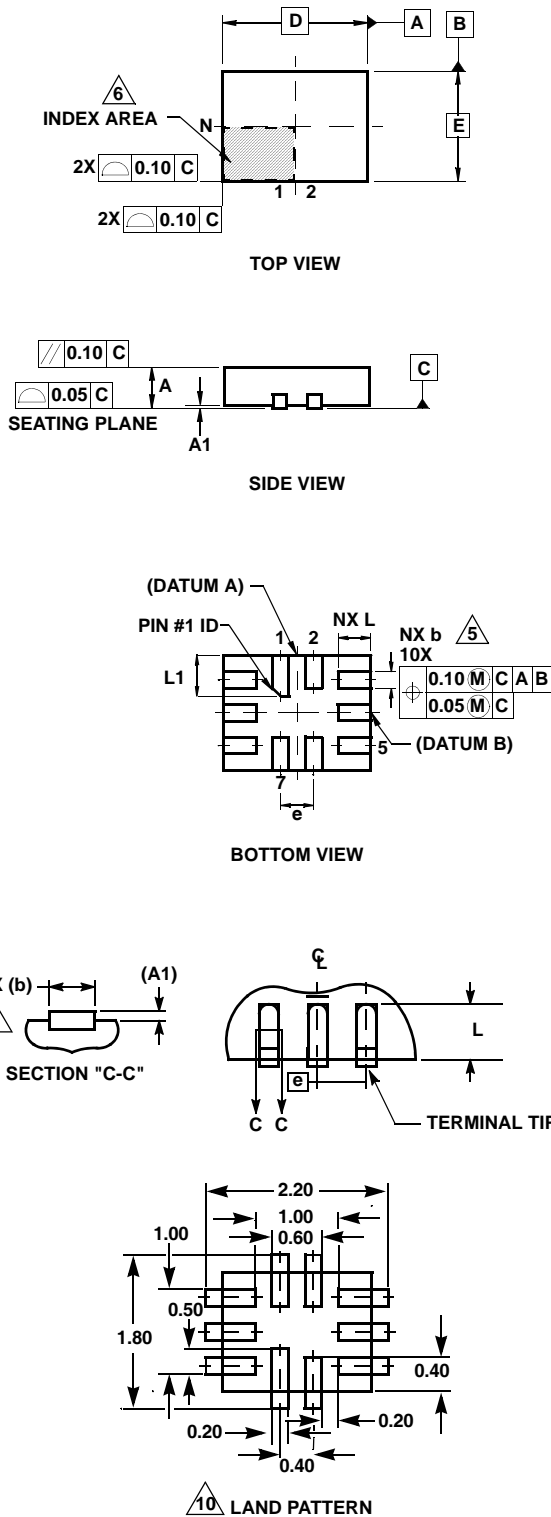

L10.1.8x1.4A
10 LEAD ULTRA THIN QUAD FLAT NO-LEAD PLASTIC PACKAGE

SYMBOL	MILLIMETERS			NOTES
	MIN	NOMINAL	MAX	
A	0.45	0.50	0.55	-
A1	-	-	0.05	-
A3	0.127 REF			-
b	0.15	0.20	0.25	5
D	1.75	1.80	1.85	-
E	1.35	1.40	1.45	-
e	0.40 BSC			-
L	0.35	0.40	0.45	-
L1	0.45	0.50	0.55	-
N	10			2
Nd	2			3
Ne	3			3
θ	0	-	12	4

Rev. 3 6/06

NOTES:

1. Dimensioning and tolerancing conform to ASME Y14.5-1994.
2. N is the number of terminals.
3. Nd and Ne refer to the number of terminals on D and E side, respectively.
4. All dimensions are in millimeters. Angles are in degrees.
5. Dimension b applies to the metallized terminal and is measured between 0.15mm and 0.30mm from the terminal tip.
6. The configuration of the pin #1 identifier is optional, but must be located within the zone indicated. The pin #1 identifier may be either a mold or mark feature.
7. Maximum package warpage is 0.05mm.
8. Maximum allowable burrs is 0.076mm in all directions.
9. JEDEC Reference MO-255.
10. For additional information, to assist with the PCB Land Pattern Design effort, see Intersil Technical Brief TB389.

All Intersil U.S. products are manufactured, assembled and tested utilizing ISO9000 quality systems. Intersil Corporation's quality certifications can be viewed at www.intersil.com/design/quality

Intersil products are sold by description only. Intersil Corporation reserves the right to make changes in circuit design, software and/or specifications at any time without notice. Accordingly, the reader is cautioned to verify that data sheets are current before placing orders. Information furnished by Intersil is believed to be accurate and reliable. However, no responsibility is assumed by Intersil or its subsidiaries for its use; nor for any infringements of patents or other rights of third parties which may result from its use. No license is granted by implication or otherwise under any patent or patent rights of Intersil or its subsidiaries.

For information regarding Intersil Corporation and its products, see www.intersil.com