

## DSP Demodulator Evaluation Board

### Evaluation Kit

The HSP50110/210EVAL kit consists of a circuit board, a Control/Status software program, the SERINADE™ FIR filter development software, and interface cables. The kit provides the necessary tools to evaluate the HSP50110 Digital Quadrature Tuner, the HSP43124 FIR Filter and the HSP50210 Digital Costas Loop integrated circuits. The evaluation kit is designed as a drop in prototype PSK demodulator for digitized (A/D converted) IF Communications Applications. The circuit board accepts an input signal of up to 10 bits of I and Q samples and recovers baseband I/Q data and symbol clock. Analog IF signals can also be processed by inserting an HI5703 A/D evaluation board between the analog source and the HSP50110/210EVAL circuit board.

### Circuit Board

Figure 1 illustrates the major functions of the evaluation circuit board. The circuit board is a 3U x 160mm VME/Eurocard form factor with dual 96 Pin I/O connectors. The connector pinouts conforms to the VME P2 Connector Pinout (i.e., power pin positions located on the middle row and I/O pin positions located on the outer rows). Data enters the board on the P1 96 Pin Plug Connector and is routed through the HSP50110 Digital Quadrature Tuner to the HSP50210 Digital Costas Loop. Data leaves the board through the P2 Plug Connector. For applications requiring custom filtering, the HSP43124 Serial I/O FIR Filter can be inserted in the data path prior to the Digital Costas Loop. An on-board microcontroller, a Motorola 68HC11, provides a control and status interface to the serial port of a Personal Computer (PC) running the Control/Status Software Program. The microcontroller EPROM contains the Motorola Monitor Program which provides the serial interface to the PC. Test connectors are provided at key signal and control locations in the demodulator circuit.

## Features

- Evaluation Kit for the HSP50110 Digital Quadrature Tuner and the HSP50210 Digital Costas Loop
- PSK Demodulator Board for Rapid Prototyping
- Interfaces with HI5703 A/D Evaluation Boards for Analog Inputs
- Interfaces to PC Serial Port
- DOS Based Control/Status Software
- HSP43124 Serial FIR Filters for Custom Filtering
- SERINADE FIR Filter Design Software
- Power and RS232 Cables Supplied

## Applications

- Prototyping Tool for PSK Communication Receivers
- PSK Demodulators from 1 KBPS to 2.5 MBPS
- Bit Synchronizers
- Digital Downconversion
- Narrowband Tracking Filters

## Functional Block Diagram

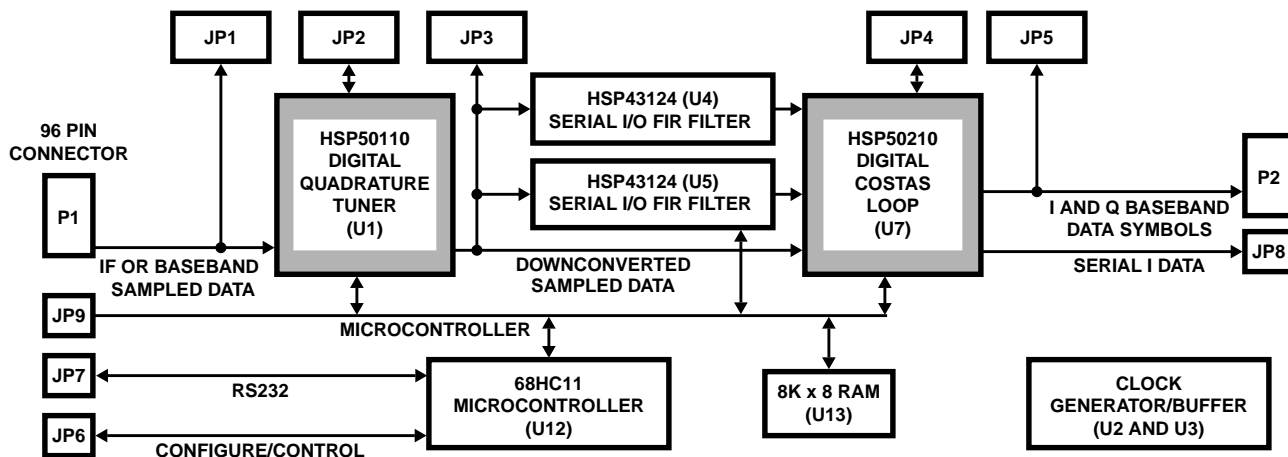

FIGURE 1.

Appendices A through H contain detailed information about Circuit Board Layout, Initial Jumper Settings, Connector Pin Assignments, Test Header Pin definitions, Detailed Schematics, Parts List, Memory Maps and a Descriptive File List.

**Control/Status Software Program**

The Control/Status Software Program, written for DOS based PC's, is included in the evaluation kit. This software supports operation of the evaluation circuit board in basic PSK Demodulator and Phased Locked Loop (PLL) configurations. The menu driven software program allows the user to select a variety of demodulator and data path configurations. It calculates demodulator/PLL configuration data based on the user menu selections, downloads configuration data to the evaluation circuit board and displays operational status. The calculated configuration data are the register values for the IC's on the evaluation board. This data is downloaded to the evaluation circuit board microcontroller using the COM1 or COM2 serial port on the PC. Status is read from Circuit Board Registers using the same serial interface and displayed on the computer screen. The downloaded configuration data is available in a text file to facilitate editing, printing, or exporting. Additionally, the software can configure the HSP43124 FIR filter by importing .RPT files generated using SERINADE, an Intersil Filter Design Application.

The Control/Status Software MAIN MENU offers six submenus for various configuration selections and three command actions. The menu tree is illustrated in Figure 2.

The six configuration submenus are:

- Data Path/Modulation Setup Menu
- Carrier Tracking Loop Setup Menu
- Bit Synchronization Loop Setup Menu

- Acquisition/Tracking Setup Menu
- Configure Hardware Menu
- Generate Output Files

The three command actions are:

- Load Configuration File
- Save Configuration File
- Exit

A typical operational sequence is:

A. Load Configuration File.

Executing this MAIN MENU item brings up a screen with the current file name and requests the name of the file to be loaded. Once the new filename name is entered, this command loads the configuration setup and returns to the MAIN MENU screen. This command allows the user to select a previously saved configuration file for display, review and editing.

B. Edit Configuration File.

This is done by sequencing through each of the configuration submenus and adjusting the parameters for the desired hardware configuration.

- The DATA PATH/MODULATION SETUP MENU is used to select clock rates, modulation type, filtering, signal levels, SNR range and I/O formats.
- The CARRIER TRACKING LOOP SETUP MENU is used to select loop bandwidth, loop filter order, damping coefficient, sweep rate, and limits for both Carrier acquisition and tracking.
- The BIT SYNC LOOP SETUP MENU is used to select loop bandwidth, loop filter order, damping coefficient, and limits for both Bit Timing tracking and acquisition.

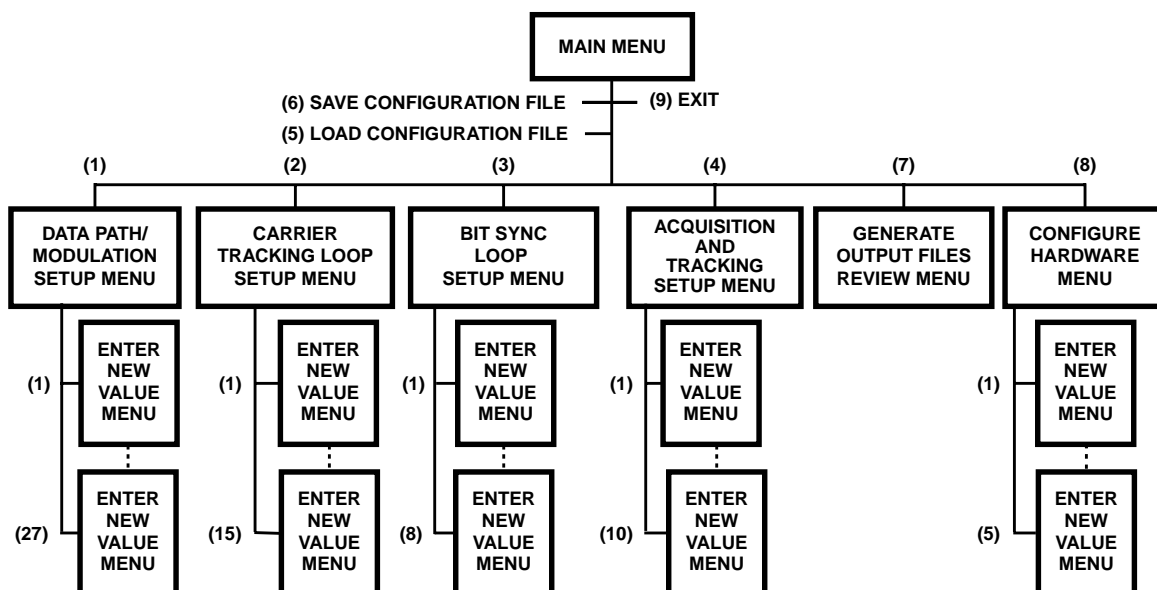

FIGURE 2. MENU TREE FOR THE CONTROL/STATUS SOFTWARE

- The ACQUISITION AND TRACKING SETUP MENU is used to select lock detection integration time, lock detection thresholds and other acquisition and tracking parameters.

C. Save Configuration File

Executing this MAIN MENU item brings up a screen with the current file name and a request for a filename to be saved. Once the new filename name is entered, this command stores the configuration setup to the new file.

D. Generate Output Files

This command will generate a number of intermediate files which contain the register values for the IC's on the evaluation circuit board. Four of the files, IFIRCOEF.ARY, IFIRREG.ARY, QFIRCOEF.ARY and QFIRREG.ARY, contain FIR specific configuration and coefficient data. One additional file has a suffix of .ARY, and the prefix of the last saved configuration filename. It contains the configuration data for the Digital Tuner and Digital PLL chips.

E. Configure Hardware

This command accesses a menu called the HARDWARE INTERFACE MENU. The menu allows selection of full initialization, loading of only the HSP50110 and HSP50210 IC's, loading of only the FIR filters, or changing only one specific register. Full initialization should be selected the first time the evaluation board is configured. Selection of items 1 - 5 will create a number of .S files that transfer the configuration data to the microcontroller on the evaluation circuit board and call microcontroller subroutines that load the data into the IC's on the evaluation board.

D. Display Status

This command in the HARDWARE INTERFACE MENU configures the PC screen to display a variety of status information.

Should further adjustment in the configuration be required, a partial hardware download can be done using the same

process and using a command item other than full Initialization in the Hardware Interface Menu.

For a detailed listing of the every menu screen, with selection item definitions, refer to Appendix I.

**Configuration/Test Headers**

Ten dual row test headers located on the evaluation circuit board are used to monitor signals and set control pins. The pin assignments for each of these headers are found in Appendix D. Headers JP1, 3, and 5 contain the data path signals for monitoring the input and output busses of the HSP50110 and HSP50210. Input pins for the HSP50110 have pull down resistors. Headers JP2 and JP4 contain the I/O signals for the HSP50110/210 that are not in the data path. JP2 also selects the clock source for the board. Header JP6 contains the microcontroller control signals. A microprocessor RESET function can be implemented by installing a "normally open" push button switch across Pins 9 and 10 of JP6. Header JP7 contains the RS232 connection to the 68HC11 microcontroller. Header JP8 contains the HSP50210 output I data at RS232 levels. Header JP9 allows monitoring of the microcontroller busses. JP10 contains +5V<sub>DC</sub> and ground.

**Typical Evaluation Configuration**

Figure 3 identifies the equipment configuration in a typical performance evaluation setup. A test data stream is generated in the Bit Error Rate Tester (BERT) and used by the modulator to generate a modulated IF signal. Noise and other signal impairments are summed with the IF signal, filtered, then digitized by an A/D converter. The digitized IF signal is routed to the circuit board. From the evaluation board, recovered clock and data are returned to the BERT for calculation of BER performance. A computer is connected via RS232 for control and status of the circuit board. A logic analyzer is shown for viewing real time display of the I/Q constellations, filter outputs, or error detector outputs of the HSP50210 during operation.

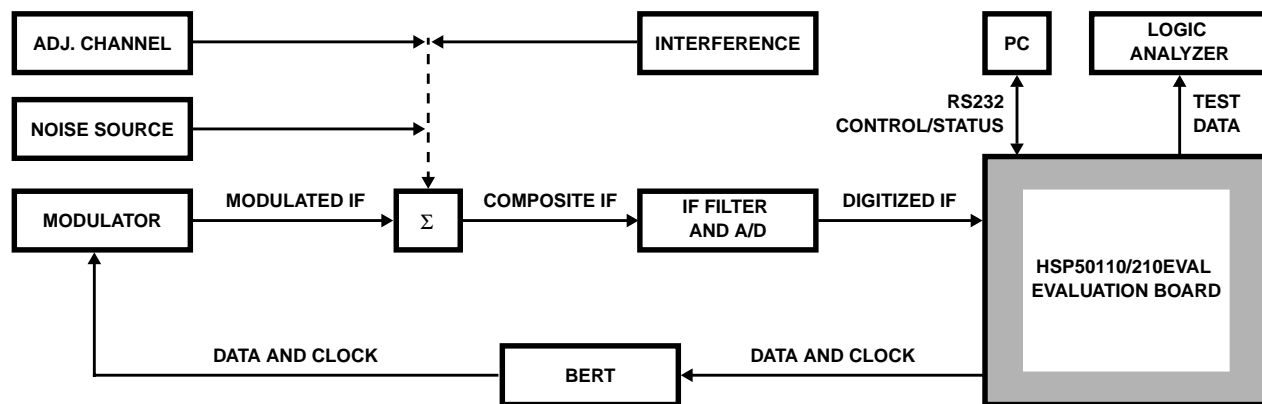

FIGURE 3. TYPICAL DEMODULATOR PERFORMANCE EVALUATION CONFIGURATION

## Getting Started

### Evaluation Circuit Board Configuration and Set Up

1. \_\_\_ Connect the serial cable, provided in the evaluation kit, to JP7 on the evaluation board.
2. \_\_\_ Connect the DB-9 end of the serial cable to the COM port on the PC.
3. \_\_\_ Connect +5 V<sub>DC</sub> to the evaluation board at J1, using the cable provided in the kit. The lead with the white stripe is the +5 V<sub>DC</sub> wire. (The board draws approximately 400mA when operated with the on board 40MHz oscillator).
4. \_\_\_ Verify that JP2 has Pin 29 jumpered to Pin 30, as well as Pin 31 jumpered to Pin 32. Installing these jumpers utilizes the on board 40MHz oscillator. (Set the jumpers on JP2, to connect Pin 29 to 30, if the on board oscillator is not desired. Supply an external clock source on Pins 3 and 4 of JP1).

The circuit board is ready for use when the +5 V<sub>DC</sub> is applied to it.

### Requirements for the Control/Status Software Program

In order to properly operate the Control/Status software program included in the evaluation kit, the PC must meet the following requirements:

PC/XT/AT or 100% compatible with a minimum of 640K of RAM

DOS Version 3.0 or higher

One serial port with 9 pin connector (COM1 or COM2)

### Installing the Software

The instructions that follow will load both the HSP50110/210EVAL and SERINADE software onto the "C" drive of the computer. If you do not wish to run the software from the "C" drive, consult your computer user's manual for operation from another drive. It is always smart practice to backup original disks prior to installing the software on your computer

1. \_\_\_ Insert the HSP50110/210EVAL disk in Drive A and copy the contents of the distribution diskette to the target directory on Drive C.
2. \_\_\_ Insert the SERINADE disk into Drive A and install the software carefully following the instructions found on page 1-1 and 1-2 of the SERINADE User's Manual.

The software must be run from the new target directory established on the C drive.

### Running the Control/Status Software Program

1. \_\_\_ On the PC, change the directory to be the one where the Control/Status software is installed.
2. \_\_\_ Start the program by typing: DEMODEVB <Enter>. The program will prompt for which COM port to use.
3. \_\_\_ Select a COM port and press <Enter>. The MAIN MENU screen will appear. It will look like Figure 4.

4. \_\_\_ Select item (5) and load B128RRC.CFG (or a configuration of your choice)
5. \_\_\_ Select MAIN MENU item (1), by typing: 1<Enter>. The DATA PATH/MODULATION MENU will appear. It should match the entries found in Figure 5.
6. \_\_\_ Make any adjustments to the parameters by entering the desired item number and editing it.
7. \_\_\_ Repeat Steps 5 and 6 for MAIN MENU items (2), (3), and (4). These Menus should match the items found in Figures 6, 7 and 8 respectively.
8. \_\_\_ Select MAIN MENU item (6) by typing 6<Enter>. This will save the edited file.
9. \_\_\_ Select MAIN MENU item (7) by typing 7<Enter>. This will calculate the configuration parameters and generate the.ARY files.
10. \_\_\_ Verify that the hardware test configuration is ready and that the evaluation circuit board has power applied to it. (Note that menu items 1 through 7 can be executed without the evaluation circuit board connected to the PC)
11. \_\_\_ Select MAIN MENU item (8) by typing 8<Enter>.
12. \_\_\_ Select HARDWARE INTERFACE MENU item (1) by typing 1<Enter>. The menu should match Figure 9. Item (1) does a full initialization of the board. Items (2) and (3) of the HARDWARE INTERFACE MENU, download the selected configurations to the HSP50110 and HSP50210, item (2), and the HSP43124 FIRs, item (3). Item (1) should be selected whenever the board has been reset. After that, item (2) can be selected for a faster update. Items (1) or (3) should be selected whenever a new FIR coefficient file is chosen.
13. \_\_\_ Select HARDWARE INTERFACE MENU item (4) by typing 4<Enter>. This starts the polling of the circuit board for status. Some of the status is only valid when the demod is tracking and thus, is not displayed during acquisition. The status display is toggled on and off by repeatedly selecting item (4).

-----  
**HSP50110/210 EVALUATION BOARD SOFTWARE**  
 -----

**MAIN MENU**

- (1) Data Path/Modulation Setup
- (2) Carrier Tracking Loop Setup
- (3) Bit Sync Loop Setup
- (4) Acquisition and Tracking Setup
- (5) Load Configuration File
- (6) Save Configuration File
- (7) Generate Output Files
- (8) Configure Hardware
- (9) Exit

ENTER SELECTION:

(C) Intersil Corporation 1995 Version 1.0

**FIGURE 4. MAIN MENU SCREEN**

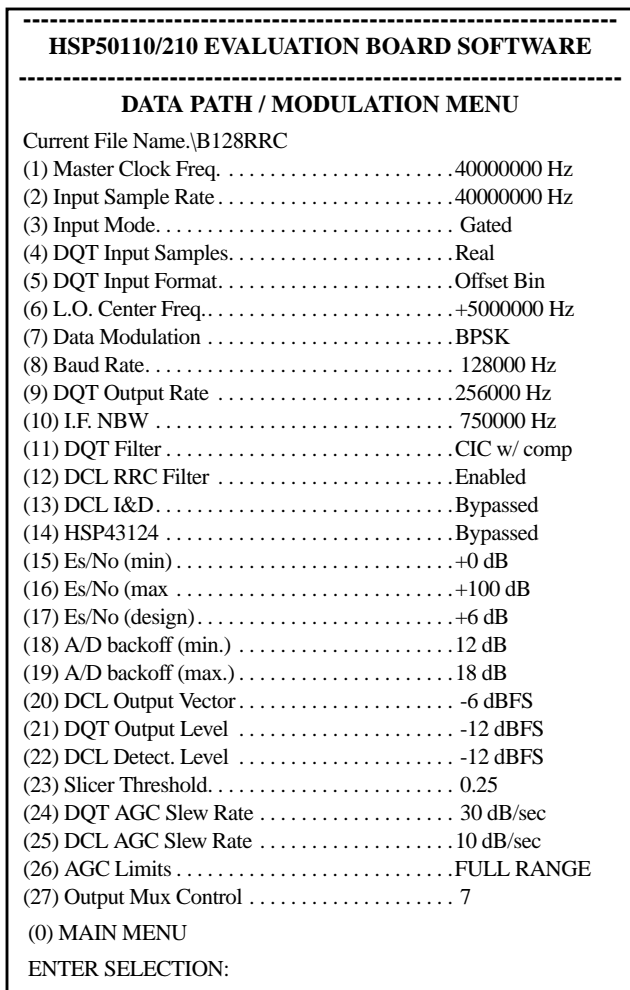
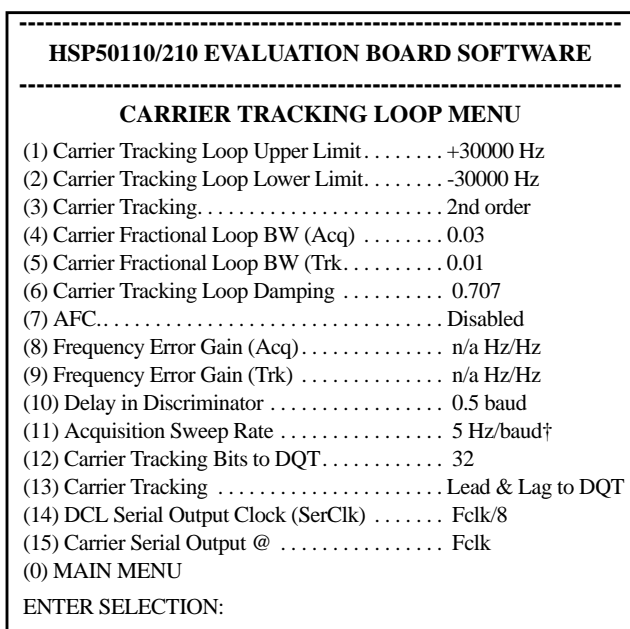

FIGURE 5. DATA PATH/MODULATION MENU



† This parameter is erroneously set 2x too high in Revision 101 of the Code. Program with a value of 1/2 of desired Sweep Rate to correct.

FIGURE 6. CARRIER TRACKING LOOP MENU

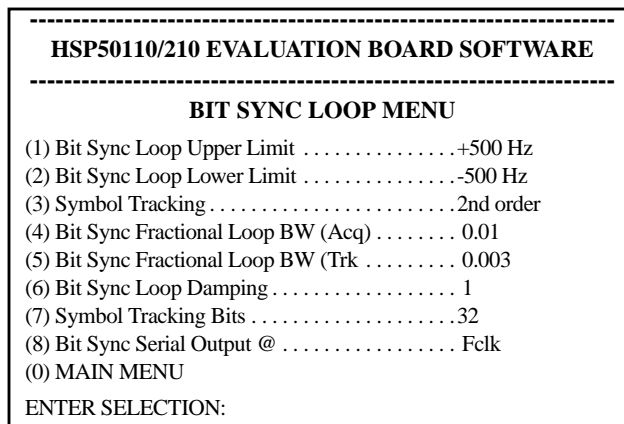

FIGURE 7. BIT SYNC LOOP MENU

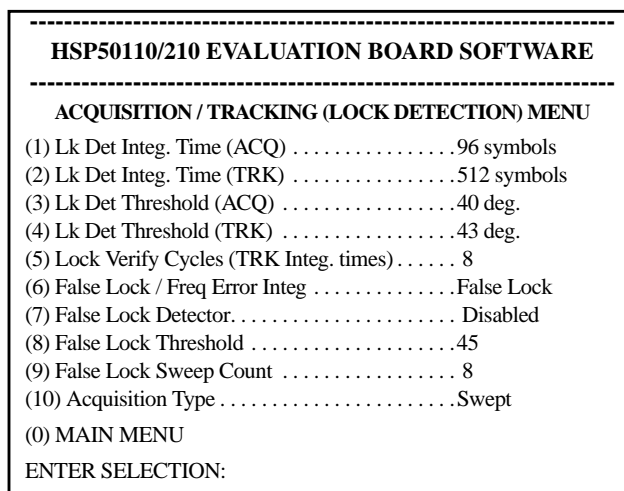

FIGURE 8. ACQUISITION/TRACKING (LOCK DETECTION)

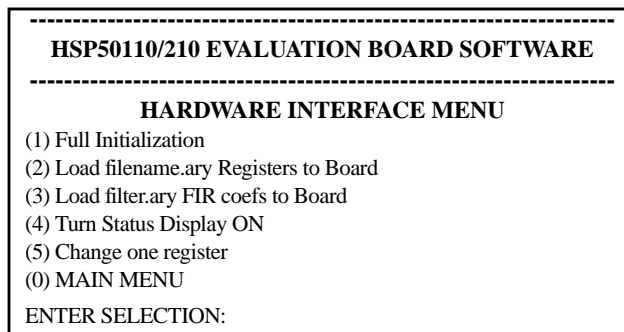

FIGURE 9. HARDWARE INTERFACE MENU

The hardware is now configured as a 128 KBPS BPSK demodulator with root raised cosine data filters. The Control/Status software is now configured to report status to the screen so that you can evaluate the performance of the demodulator configuration.

## Advanced Evaluation Configurations

### Terminal/PC With Terminal Emulation Control of Evaluation Board

The user has the option of communicating directly with the evaluation board microcontroller monitor program using a "dumb terminal" or a PC with a communications program such as Terminal under Microsoft Windows™. The COM port settings are 4800 baud, 8 bits, 1 stop bit, and no parity. The download (.DLD) files generated by the Control/Status software contain monitor commands for loading the HSP Registers. A terminal emulator program can be used to send these files to the monitor program as a text file download. Faster transfers result when using "Line at a Time" versus other download options because the text transfers wait only for the prompt string ">".

1. On reset, the monitor program sends a greeting.
2. Press enter and the monitor will return a prompt.
3. To display a help screen, send "?".
4. To initialize the 68HC11 to communicate with the HSP parts, enter the following commands:  
MM 005A  
00 88 08 03 04 01  
This sets up the memory map and address decoding.

The memory map for the 68HC11 is provided in Appendix G. A list of the file types on the distribution disk with a brief description, is provided in Appendix H.

For further information on the MC68HC11K4 microprocessor, reference the following Motorola data books:

Motorola M68HC11 Reference Manual (M68HC11RM/AD)

Motorola MC68HC11K4 Technical Data (MC68HC11K4/D)

The source code for the monitor program (BUFK4.ASM, .S19, and .LST) is available on the Motorola's bulletin board for microprocessor products. It can be accessed using either anonymous ftp to freeware.aus.sps.mot.com or via modem at (512) 891-3733 (8 bits, 1 stop bit, no parity).

### Serial Data Output at RS232 Levels

A user can read the I symbol serial data directly from the output bus of the HSP50210 at RS232 levels using JP8-3. JP4 must have Pin 31 jumpered to Pin 32 to connect the output data to RS232 driver, U8.

### Using SERINADE Designed Filters

Once SERINADE has been used to synthesize a filter, it is possible to use this filter design in the FIR filters in the demodulator on the evaluation board. This procedure assumes that the SERINADE .RPT files are available for import. Version 1.1 or higher is recommended.

### Root Raised Cosine Filter

Several filter coefficient files have been included on the HSP50110/210EVAL disk because the SERINADE Program

does not compute square root of raised cosine filters. These files are provided for import into SERINADE. Select FIR type: *Imported* on the SERINADE design menu screen. SERINADE will add the control register values for the raised cosine filter and any half band stages that you might select. SERINADE will generate the .RPT files as before. The root raised cosine coefficient files have been provided for alpha = 0.2, 0.35, 0.4, and 0.5 at 2X, 4X, and 8X baud rate. The impulse response length is 8 baud intervals for all cases.

### Non Demodulator Configurations

If other configurations are needed, the software can be used to generate computed data gain, filtering, and I/O settings. These settings can be downloaded as a file, as before, or modified as individual register IC parameters after an initial download.

### Detailed Circuit Description

The reader should reference the detailed schematics, found in Appendix E, while reading the detailed circuit description.

### Signal Path

The signal path begins with digitized IF data samples input to the P1 connector. These data samples form a complex data bus, 10 bits of each I and Q samples, which is routed to the input of the HSP50110 Digital Quadrature Tuner, U. Pull down resistors, RZ1-3, are provided for unused inputs. If the input sampled IF data format is offset binary and it is a real signal (either I or Q data only), the MSB of the unused input bus (I or Q) should be pulled up to a logic "1" to set the bus to midscale. Because all of the P1 signals pass through test header JP1, it can also serve as an input connector. In addition to the P1 signals, JP1 has two HSP50110 signals, the input enable signal  $\overline{DQTENI}$  and the output signal DQTHI/LO. JP1 also has the AGCLVL input signal for the 68HC11 internal A/D converter. The external access to the  $\overline{DQTENI}$  signal provided on P1 allows the HSP50110 to be evaluated in both the gated input and interpolated input modes. The DQTHI/LO, when externally filtered, can be used in designing an Automatic Gain Control (AGC) circuit around the IF A/D converter. Both the threshold and logic sense of the DQTHI/LO signal are programmable. The AGCLVL signal is the return path for an external analog AGC signal. The AGCLVL signal is digitized and read by the processor.

The digital downconverted complex parallel bus output of the HSP50110 Digital Quadrature Tuner is routed to the HSP50210 Digital Costas Loop, U7. This parallel bus is also routed through test header JP3. The baseband data ready signal ( $\overline{BBDRDY}$ ), HSP50210 input AGC signal (DCLHI/LO), and the 68HC11 imbedded A/D input (AGCLVL) are also provided on JP3. The  $\overline{BBDRDY}$  provides synchronization for the parts following the HSP50110. The DCL HI/LO is provided to allow external filtering for use of this signal in

designing an AGC circuit around the A/D converter when the HSP50110 is bypassed. The AGCLVL signal is the return path for an external analog AGC signal. The AGCLVL signal is digitized and read by the processor. Test header JP2 contains the remaining output signals from the HSP50110, control inputs for the HSP50110, and card clock source/polarity jumpered selections.

The serial outputs of the Digital Quadrature Tuner, IBB0 and QBB0, are routed to two HSP43124 Serial I/O filters, U4 and U5, and then to the U7, Digital Costas Loop, serial input. This filtered serial signal path is provided for those applications requiring special filtering beyond the Root Raised Cosine (RRC) and Integrate and Dump (I&D) filters offered by the HSP50210 Digital Costas Loop integrated circuit. An Octal Register, U6, is provided to ensure that setup and hold times are guaranteed up to the 45MHz maximum clock rate of the FIR filters. Selection of signal routing to the FIR filters is done in the DATA PATH/MODULATION MENU, item (14). A set of .ARY files (two each for I and Q FIR filter) is generated by the program. Selecting the DATA PATH/MODULATION MENU item (14) and identifying a .RPT file, sets the FIR filter response. The HARDWARE INTERFACE MENU item (3) allows the download of only the FIR filter files and is useful when only the FIR filters need to be changed.

The I and Q output busses from the HSP50210, and the high speed output clock are routed through the test header JP5 to the 96 pin connector, P2. When a jumper is placed between JP-5 pins 29 and 31, the data rate clock (DATACLK) is provided on both JP5 and P2. The I/Q output enable and loop freeze control inputs, along with the loop tracking outputs of the HSP50210, are routed to header JP4. Pin assignments for all connectors and headers are provided in Appendices C and D.

## Clocking

### Jumpered Options

The clock associated with the digitized IF samples can be input at P1 Pin 20 if the card is configured for external clock (JP2 header Pins 29-30). If the card is configured for internal 40MHz reference clock (JP2 header Pins 29-31 and 30-32), then the 40MHz reference clock is output on P1 Pin 20. Three ACT86 gates (U3) isolate the on-board and off-board clock signals, allow different polarities for the clocks, and provide the 3.0V minimum  $V_{IH}$  required by the HSP parts. Installing a jumper between J2-25 and 26 inverts clock for the Digital Quadrature Tuner, the Digital PLL and the FIR Filters. Installing a jumper between J2-27 and 28 inverts the high speed output clock.

## Microcontroller

An on-board microcontroller, a 68HC11, provides the control and status of the evaluation board. It includes RAM, EPROM (programmed with Motorola's BUFFALO™ monitor program), EEPROM, a serial port, address decoding, a synchronous serial port, an A/D converter, and other features. U8 provides the RS232 drive levels for the serial port, JP7. U13 is an 8K x 8 static RAM for 68HC11 program and data storage. U14 provides the address decoding for the HSP parts. U15 provides additional address decoding that is brought to JP9. U9 and U10 are the power-on reset and optional switch controlled reset voltage detectors. U11 is the 8MHz oscillator for the 68HC11. JP8 provides an RS232 port for the I channel received symbol data stream when JP4 pins 31 and 32 are jumpered. JP6 provides for jumpering the operating mode of the 68HC11, installing a RESET switch, and applying 12.25V for the programming the 68HC11 EPROM.

The jumper options for JP6 are:

| Pins 1-2  | Description   |                               |
|-----------|---|-------------------------------|
| No Jumper | IRQB = 1 (Note 1)   |                               |
| Jumpered  | HSP50110 LKDET INT = IRQB   |                               |
| Pins 3-4  | Pins 5-6  | Description                   |
| Jumpered  | Jumpered  | Special HC11 Bootstrap Mode   |
| No Jumper | Jumpered  | Special HC11 Test Mode        |
| Jumpered  | No Jumper   | Special HC11 Single Chip Mode |
| No Jumper | No Jumper   | Expanded HC11 Mode (Note 1)   |
| Pins 7-8  | Description   |                               |
| No Jumper | XIRQ = Program Voltage (pin 8) (Note 1)                                 |                               |
| Jumpered  | XIRQ = 0 (GND)  |                               |
| Pins 9-10 | Description   |                               |
| No Jumper | OPERATE (Note 1)  |                               |
| Jumpered  | Microprocessor RESET (temporary connection only, is required for RESET) |                               |

NOTE:

1. Indicates normal operational mode for the evaluation board JP9 is provided for monitoring the microcontroller and provides access to the address bus, the data bus, the SPI port, control signals, and general purpose I/O signals.

## Power Supply Connections

The +5V input jack is J1. The +5V can be supplied from any generic +5V<sub>DC</sub>/500mA AC/DC power adapter. A cable that has the mating connector to J1 is provided with the evaluation kit for use with a standard laboratory power supply. A zener diode provides some protection against overvoltage or polarity reversal. The J1 input is fused for protection from excessive current draw. V<sub>CC</sub> and GND connections can also be made at the JP10 header, or at either the P1 or P2 connectors. The supply pins on these 96 Pin connectors match VME P2 Pins for +5V and ground and also are compatible with the supply pins on other Intersil evaluation boards. The evaluation board draws approximately 400mA at 40MHz.

**Appendix A**

**Circuit Board Layout**

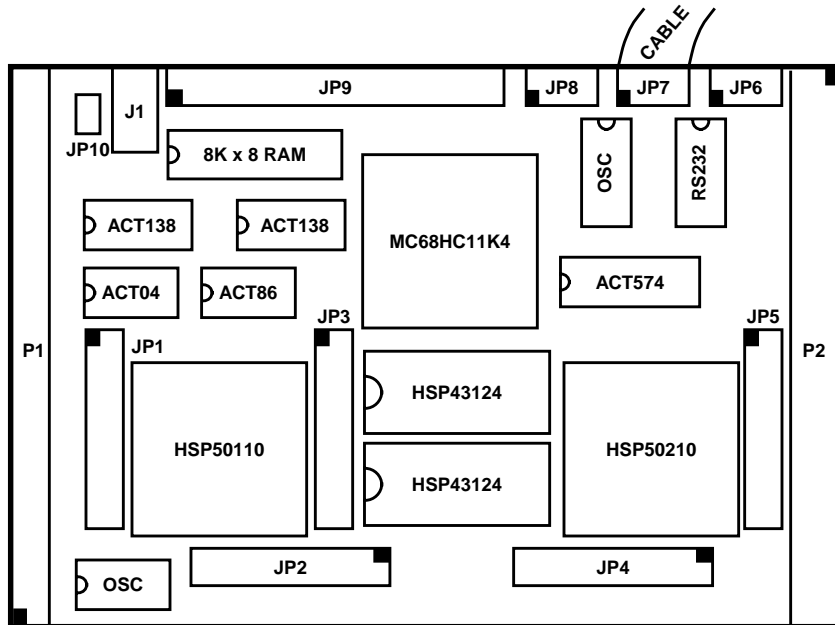

**Appendix B**

**Initial Jumper Settings**

**INITIAL JUMPER SETTINGS**

| FROM   | TO     |
|--------|--------|
| JP2-1  | JP2-2  |
| JP2-3  | JP2-4  |
| JP2-5  | JP2-6  |
| JP2-7  | JP2-8  |
| JP2-9  | JP2-10 |
| JP2-29 | JP2-30 |
| JP4-1  | JP4-2  |
| JP4-3  | JP4-4  |
| JP4-5  | JP4-6  |
| JP4-7  | JP4-8  |

**Appendix C**

**P1 and P2 Connector Pin Assignations**

**P1 CONNECTOR PIN ASSIGNMENTS**

| PIN | SIGNAL | PIN | SIGNAL | PIN | SIGNAL |
|-----|--------|-----|--------|-----|--------|
| A1  | N/C    | B1  | +5V    | C1  | GND    |
| A2  | N/C    | B2  | GND    | C2  | N/C    |
| A3  | N/C    | B3  | N/C    | C3  | N/C    |
| A4  | N/C    | B4  | N/C    | C4  | N/C    |
| A5  | QI0    | B5  | N/C    | C5  | QI1    |
| A6  | GND    | B6  | N/C    | C6  | QI2    |
| A7  | QI3    | B7  | N/C    | C7  | QI4    |
| A8  | QI5    | B8  | N/C    | C8  | QI6    |
| A9  | QI7    | B9  | N/C    | C9  | QI8    |
| A10 | QI9    | B10 | N/C    | C10 | GND    |
| A11 | N/C    | B11 | N/C    | C11 | N/C    |
| A12 | N/C    | B12 | GND    | C12 | N/C    |
| A13 | N/C    | B13 | +5V    | C13 | N/C    |
| A14 | N/C    | B14 | N/C    | C14 | II0    |
| A15 | II1    | B15 | N/C    | C15 | GND    |
| A16 | II2    | B16 | N/C    | C16 | II3    |
| A17 | II4    | B17 | N/C    | C17 | II5    |
| A18 | II6    | B18 | N/C    | C18 | II7    |
| A19 | II8    | B19 | N/C    | C19 | II9    |
| A20 | GND    | B20 | N/C    | C20 | CLKIN  |
| A21 | GND    | B21 | N/C    | C21 | N/C    |
| A22 | GND    | B22 | GND    | C22 | N/C    |
| A23 | GND    | B23 | N/C    | C23 | N/C    |
| A24 | GND    | B24 | N/C    | C24 | N/C    |
| A25 | GND    | B25 | N/C    | C25 | N/C    |
| A26 | N/C    | B26 | N/C    | C26 | N/C    |
| A27 | N/C    | B27 | N/C    | C27 | N/C    |
| A28 | N/C    | B28 | N/C    | C28 | N/C    |
| A29 | N/C    | B29 | N/C    | C29 | N/C    |
| A30 | N/C    | B30 | N/C    | C30 | GND    |
| A31 | N/C    | B31 | GND    | C31 | N/C    |
| A32 | N/C    | B32 | +5V    | C32 | N/C    |

**P2 CONNECTOR PIN ASSIGNMENTS**

| PIN | SIGNAL | PIN | SIGNAL | PIN | SIGNAL |
|-----|--------|-----|--------|-----|--------|
| A1  | N/C    | B1  | +5V    | C1  | GND    |
| A2  | N/C    | B2  | GND    | C2  | N/C    |
| A3  | N/C    | B3  | N/C    | C3  | N/C    |
| A4  | N/C    | B4  | N/C    | C4  | N/C    |
| A5  | BO0    | B5  | N/C    | C5  | BO1    |
| A6  | GND    | B6  | N/C    | C6  | BO2    |
| A7  | BO3    | B7  | N/C    | C7  | BO4    |
| A8  | BO5    | B8  | N/C    | C8  | BO6    |
| A9  | BO7    | B9  | N/C    | C9  | BO8    |
| A10 | BO9    | B10 | N/C    | C10 | GND    |
| A11 | N/C    | B11 | N/C    | C11 | N/C    |
| A12 | N/C    | B12 | GND    | C12 | N/C    |
| A13 | N/C    | B13 | +5V    | C13 | N/C    |
| A14 | N/C    | B14 | N/C    | C14 | AO0    |
| A15 | AO1    | B15 | N/C    | C15 | GND    |
| A16 | AO2    | B16 | N/C    | C16 | AO3    |
| A17 | AO4    | B17 | N/C    | C17 | AO5    |
| A18 | AO6    | B18 | N/C    | C18 | AO7    |
| A19 | AO8    | B19 | N/C    | C19 | AO9    |
| A20 | GND    | B20 | N/C    | C20 | CLKOUT |
| A21 | GND    | B21 | N/C    | C21 | GPOUT  |
| A22 | GND    | B22 | GND    | C22 | N/C    |
| A23 | GND    | B23 | N/C    | C23 | N/C    |
| A24 | GND    | B24 | N/C    | C24 | N/C    |
| A25 | GND    | B25 | N/C    | C25 | N/C    |
| A26 | N/C    | B26 | N/C    | C26 | N/C    |
| A27 | N/C    | B27 | N/C    | C27 | N/C    |
| A28 | N/C    | B28 | N/C    | C28 | N/C    |
| A29 | N/C    | B29 | N/C    | C29 | N/C    |
| A30 | N/C    | B30 | N/C    | C30 | GND    |
| A31 | N/C    | B31 | GND    | C31 | N/C    |
| A32 | N/C    | B32 | +5V    | C32 | N/C    |

**Appendix D**

**JP1 through JP10 Test Header Pin Assignments**

**JP1 TEST HEADER PIN ASSIGNMENTS**

| PIN | SIGNAL              | DESCRIPTION             | PIN | SIGNAL | DESCRIPTION             |
|-----|---------------------|-------------------------|-----|--------|-------------------------|
| 1   | DQTHI/LO            | DQT HI/LO Signal        | 2   | GND    | Ground                  |
| 3   | CLKIN               | Input Clock to Board    | 4   | GND    | Ground                  |
| 5   | II9                 | I Input Bus Bit 9 (MSB) | 6   | II8    | I Input Bus Bit 8       |
| 7   | II7                 | I Input Bus BIT 7       | 8   | II6    | I Input Bus Bit 6       |
| 9   | II5                 | I Input Bus BIT 5       | 10  | II4    | I Input Bus Bit 4       |
| 11  | II3                 | I Input Bus BIT 3       | 12  | II2    | I Input Bus Bit 2       |
| 13  | II1                 | I Input Bus BIT 1       | 14  | II0    | I Input Bus Bit 0 (LSB) |
| 15  | GND                 | Ground                  | 16  | GND    | Ground                  |
| 17  | QI9                 | Q Input Bus Bit 9 (MSB) | 18  | QI8    | Q Input Bus Bit 8       |
| 19  | QI7                 | Q Input Bus Bit 7       | 20  | QI6    | Q Input Bus Bit 6       |
| 21  | QI5                 | Q Input Bus Bit 5       | 22  | QI4    | Q Input Bus Bit 4       |
| 23  | QI3                 | Q Input Bus Bit 3       | 24  | QI2    | Q Input Bus Bit 2       |
| 25  | QI1                 | Q Input Bus Bit 1       | 26  | QI0    | Q Input Bus Bit 0(LSB)  |
| 27  | GND                 | Ground                  | 28  | GND    | Ground                  |
| 29  | $\overline{DQTENI}$ | DQT Input Enable        | 30  | GND    | Ground                  |
| 31  | AGCLVL              | A/D Input to 68HC11     | 32  | GND    | Ground                  |

**JP2 TEST HEADER PIN ASSIGNMENTS**

| PIN | SIGNAL | DESCRIPTION          | PIN | SIGNAL              | DESCRIPTION           |
|-----|--------|----------------------|-----|---------------------|-----------------------|
| 1   | GND    | Ground               | 2   | DQTPH1              | DQT Phase Shift Bit1  |
| 3   | GND    | Ground               | 4   | DQTPH0              | DQT Phase Shift Bit 0 |
| 5   | GND    | Ground               | 6   | DQTCFLD             | DQT Center Freq Load  |
| 7   | GND    | Ground               | 8   | $\overline{DQTOEI}$ | DQT Output Enable I   |
| 9   | GND    | Ground               | 10  | $\overline{DQTOEQ}$ | DQT Output Enable Q   |
| 11  | GND    | Ground               | 12  | DQTLOTP             | DQT L.O. Test Point   |
| 13  | GND    | Ground               | 14  | SPH0                | Bit Sync Phase Bit 0  |
| 15  | GND    | Ground               | 16  | SPH1                | Bit Sync Phase Bit 1  |
| 17  | GND    | Ground               | 18  | SPH2                | Bit Sync Phase Bit 2  |
| 19  | GND    | Ground               | 20  | SPH3                | Bit Sync Phase Bit 3  |
| 21  | GND    | Ground               | 22  | SPH4                | Bit Sync Phase Bit 4  |
| 23  | GND    | Ground               | 24  | $\overline{SSTRB}$  | Bit Sync Strobe       |
| 25  | GND    | Ground               | 26  | INVDCLK             | Invert Demod Clock    |
| 27  | GND    | Ground               | 28  | INVCKOUT            | Invert Output Clock   |
| 29  | CLKIN  | Input Clock to Board | 30  | MSTRCLK             | Master Clock Node     |
| 31  | DRVCLK | Clock Driver         | 32  | OSCCLK              | Oscillator Output     |

NOTE: To input the clock to the board, connect pin 29 to 30; to source the clock from the on-board oscillator, connect pin 29 to 31 and pin 30 to 32.

## HSP50110/210EVAL

### JP3 TEST HEADER PIN ASSIGNMENTS

| PIN | SIGNAL                     | DESCRIPTION            | PIN | SIGNAL | DESCRIPTION            |
|-----|----------------------------|------------------------|-----|--------|------------------------|
| 1   | DCLHI/LO                   | DCL HI/LO Signal       | 2   | GND    | Ground                 |
| 3   | DEMOCCLK                   | Chipset Master Clock   | 4   | GND    | Ground                 |
| 5   | IBB9                       | I Baseband Bit 9 (MSB) | 6   | IBB8   | I Baseband Bit 8       |
| 7   | IBB7                       | I Baseband Bit 7       | 8   | IBB6   | I Baseband Bit 6       |
| 9   | IBB5                       | I Baseband Bit 5       | 10  | IBB4   | I Baseband Bit 4       |
| 11  | IBB3                       | I Baseband Bit 3       | 12  | IBB2   | I Baseband Bit 2       |
| 13  | IBB1                       | I Baseband Bit 1       | 14  | IBB0   | I Baseband Bit 0 (LSB) |
| 15  | GND                        | Ground                 | 16  | GND    | Ground                 |
| 17  | QBB9                       | Q Baseband Bit 9 (MSB) | 18  | QBB8   | Q Baseband Bit 8       |
| 19  | QBB7                       | Q Baseband Bit 7       | 20  | QBB6   | Q Baseband Bit 6       |
| 21  | QBB5                       | Q Baseband Bit 5       | 22  | QBB4   | Q Baseband Bit 4       |
| 23  | QBB3                       | Q Baseband Bit 3       | 24  | QBB2   | Q Baseband Bit 2       |
| 25  | QBB1                       | Q Baseband 1           | 26  | QBB0   | Q Baseband Bit 0 (LSB) |
| 27  | GND                        | Ground                 | 28  | GND    | Ground                 |
| 29  | $\overline{\text{BBDRDY}}$ | DCL Input Enable       | 30  | GND    | Ground                 |
| 31  | AGCLVL                     | A/D Input to 68HC11    | 32  | GND    | Ground                 |

### JP4 TEST HEADER PIN ASSIGNMENTS

| PIN | SIGNAL | DESCRIPTION        | PIN | SIGNAL                  | DESCRIPTION           |
|-----|--------|--------------------|-----|-------------------------|-----------------------|
| 1   | GND    | Ground             | 2   | $\overline{\text{OEA}}$ | A Bus Output Enable   |
| 3   | GND    | Ground             | 4   | $\overline{\text{OEB}}$ | B Bus Output Enable   |
| 5   | GND    | Ground             | 6   | FRZBS                   | Disable Baud Track    |
| 7   | GND    | Ground             | 8   | FRZCAR                  | Disable Carrier Track |
| 9   | GND    | Ground             | 10  | THRESH                  | Level Detector Out    |
| 11  | GND    | Ground             | 12  | SOFSYNC                 | Baud Offset Sync      |
| 13  | GND    | Ground             | 14  | SOF                     | Baud Rate Offset      |
| 15  | GND    | Ground             | 16  | COFSYNC                 | Carrier Offset Sync   |
| 17  | GND    | Ground             | 18  | COF                     | Carrier Offset        |
| 19  | GND    | Ground             | 20  | SLOWCLK                 | Slow Serial Clock     |
| 21  | GND    | Ground             | 22  |                         | No Connect            |
| 23  | GND    | Ground             | 24  |                         | No Connect            |
| 25  | GND    | Ground             | 26  |                         | No Connect            |
| 27  | GND    | Ground             | 28  |                         | No Connect            |
| 29  | GND    | Ground             | 30  |                         | No Connect            |
| 31  | RXDI   | RS232 Driver Input | 32  | AO9                     | I Channel MSB (AOUT9) |

## HSP50110/210EVAL

### JP5 TEST HEADER PIN ASSIGNMENTS

| PIN | SIGNAL  | DESCRIPTION                               | PIN | SIGNAL | DESCRIPTION        |
|-----|---------|---|-----|--------|--------------------|
| 1   |         | No Connect                                | 2   | GND    | Ground             |
| 3   | CLKOUT  | Output Clock                              | 4   | GND    | Ground             |
| 5   | AO9     | A Output Bus Bit 9                        | 6   | AO8    | A Output Bus Bit 8 |
| 7   | AO7     | A Output Bus Bit 7                        | 8   | AO6    | A Output Bus Bit 6 |
| 9   | AO5     | A Output Bus Bit 5                        | 10  | AO4    | A Output Bus Bit 4 |
| 11  | AO3     | A Output Bus Bit 3                        | 12  | AO2    | A Output Bus Bit 2 |
| 13  | AO1     | A Output Bus Bit 1                        | 14  | AO0    | A Output Bus Bit 0 |
| 15  | GND     | Ground                                    | 16  | GND    | Ground             |
| 17  | BO9     | B Output Bus Bit 9                        | 18  | BO8    | B Output Bus Bit 8 |
| 19  | BO7     | B Output Bus Bit 7                        | 20  | BO6    | B Output Bus Bit 6 |
| 21  | BO5     | B Output Bus Bit 5                        | 22  | BO4    | B Output Bus Bit 4 |
| 23  | BO3     | B Output Bus Bit 3                        | 24  | BO2    | B Output Bus Bit 2 |
| 25  | BO1     | B Output Bus Bit 1                        | 26  | QIOB   | B Output Bus Bit 0 |
| 27  | GND     | Ground                                    | 28  | GND    | Ground             |
| 29  | DATACLK | Output Symbol Clock                       | 30  | GND    | Ground             |
| 31  | GPOUT   | Jumper to Pin 29 to Connect DATACLK to P2 | 32  | GND    | Ground             |

### JP6 TEST HEADER PIN ASSIGNMENTS

| PIN | SIGNAL   | DESCRIPTION          | PIN | SIGNAL      | DESCRIPTION            |
|-----|----------|----------------------|-----|-------------|------------------------|
| 1   | LKDETINT | Interrupt From 50210 | 2   | IRQB        | 68HC11 Interrupt Input |
| 3   | GND      | Ground               | 4   | MODB (Note) | 68HC11 Mode Select     |
| 5   | GND      | Ground               | 6   | MODA (Note) | 68HC11 Mode Select     |
| 7   | GND      | Ground               | 8   |             | No Connect             |
| 9   | PULLDWN  | Pull Down Resistor   | 10  | RSTSW       | Reset Switch Input     |

NOTE: Mode Definitions (A, B)

00--Special bootstrap mode

01--Special test mode

10--Single chip mode

11--Expanded mode (normal mode for eval board)

See the 68HC11K4 data sheet for further explanation.

### JP7 RS232 HEADER PIN ASSIGNMENTS

| PIN | SIGNAL | DESCRIPTION          | PIN | SIGNAL | DESCRIPTION |
|-----|--------|----------------------|-----|--------|-------------|
| 1   |        | No Connect           | 2   |        | No Connect  |
| 3   | TX1    | RS232 Data From HC11 | 4   |        | No Connect  |
| 5   | RX1    | RS232 Data To HC11   | 6   |        | No Connect  |
| 7   |        | No Connect           | 8   |        | No Connect  |
| 9   | GND    | Ground               | 10  |        | No Connect  |

## HSP50110/210EVAL

### JP8 RS232 HEADER PIN ASSIGNMENTS

| PIN | SIGNAL | DESCRIPTION                | PIN | SIGNAL | DESCRIPTION |
|-----|--------|----------------------------|-----|--------|-------------|
| 1   |        | No Connect                 | 2   |        | No Connect  |
| 3   | TX2    | HSP50210 Buffered AO9 Data | 4   |        | No Connect  |
| 5   |        | No Connect                 | 6   |        | No Connect  |
| 7   |        | No Connect                 | 8   |        | No Connect  |
| 9   |        | GND Ground                 | 10  |        | No Connect  |

### JP9 TEST HEADER PIN ASSIGNMENTS

| PIN | SIGNAL | DESCRIPTION         | PIN | SIGNAL  | DESCRIPTION         |
|-----|--------|---------------------|-----|---------|---------------------|
| 1   | PD0    | 6811 Data Bit 0     | 2   | GND     | Ground              |
| 3   | PD1    | 6811 Data Bit 1     | 4   | WRSTRB1 | GP Address Decode   |
| 5   | PD2    | 6811 Data Bit 2     | 6   | WRSTRB2 | GP Address Decode   |
| 7   | PD3    | 6811 Data Bit 3     | 8   | GND     | Ground              |
| 9   | PD4    | 6811 Data Bit 4     | 10  | GND     | Ground              |
| 11  | PD5    | 6811 Data Bit 5     | 12  | GND     | Ground              |
| 13  | PD6    | 6811 Data Bit 6     | 14  | GND     | Ground              |
| 15  | PD7    | 6811 Data Bit 7     | 16  | GND     | Ground              |
| 17  | GND    | Ground              | 18  | GND     | Ground              |
| 19  | R/Wb   | 6811 Read/Write     | 20  | E       | 6811 Bus Enable     |
| 21  | GND    | Ground              | 22  | CSIO    | HSP Chip Select     |
| 23  | PA0    | 6811 Address Bit 0  | 24  | PA1     | 6811 Address Bit 1  |
| 25  | PA2    | 6811 Address Bit 2  | 26  | PA3     | 6811 Address Bit 3  |
| 27  | PA4    | 6811 Address Bit 4  | 28  | PA5     | 6811 Address Bit 5  |
| 29  | PA6    | 6811 Address Bit 6  | 30  | PA7     | 6811 Address Bit 7  |
| 31  | GND    | Ground              | 32  | GND     | Ground              |
| 33  | PA8    | 6811 Address Bit 8  | 34  | PA9     | 6811 Address Bit 9  |
| 35  | PA10   | 6811 Address Bit 10 | 36  | PA11    | 6811 Address Bit 11 |
| 37  | PA12   | 6811 Address Bit 12 | 38  | PA13    | 6811 Address Bit 13 |
| 39  | PA14   | 6811 Address Bit 14 | 40  | PA15    | 6811 Address Bit 15 |
| 41  | GND    | Ground              | 42  | GND     | Ground              |
| 43  | GP0    | General Purpose I/O | 44  | GP1     | General Purpose I/O |
| 45  | GP2    | General Purpose I/O | 46  | GP3     | General Purpose I/O |
| 47  | GP4    | General Purpose I/O | 48  | GP5     | General Purpose I/O |
| 49  | GP6    | General Purpose I/O | 50  | GP7     | General Purpose I/O |
| 51  | GP8    | General Purpose I/O | 52  | GP9     | General Purpose I/O |
| 53  | GP10   | General Purpose I/O | 54  | GP11    | General Purpose I/O |
| 55  | GND    | Ground              | 56  | GND     | Ground              |
| 57  | SCK    | SPI Port Clock      | 58  | SSB     | SPI Port Strobe     |
| 59  | MISO   | SPI Port I/O        | 60  | MOSI    | SPI Port I/O        |

### P10 POWER HEADER

| PIN | SIGNAL          | DESCRIPTION | PIN | SIGNAL | DESCRIPTION |
|-----|-----------------|-------------|-----|--------|-------------|
| 1   | V <sub>CC</sub> | +5V         | 2   | GND    | Ground      |

Appendix E

Detailed Schematics

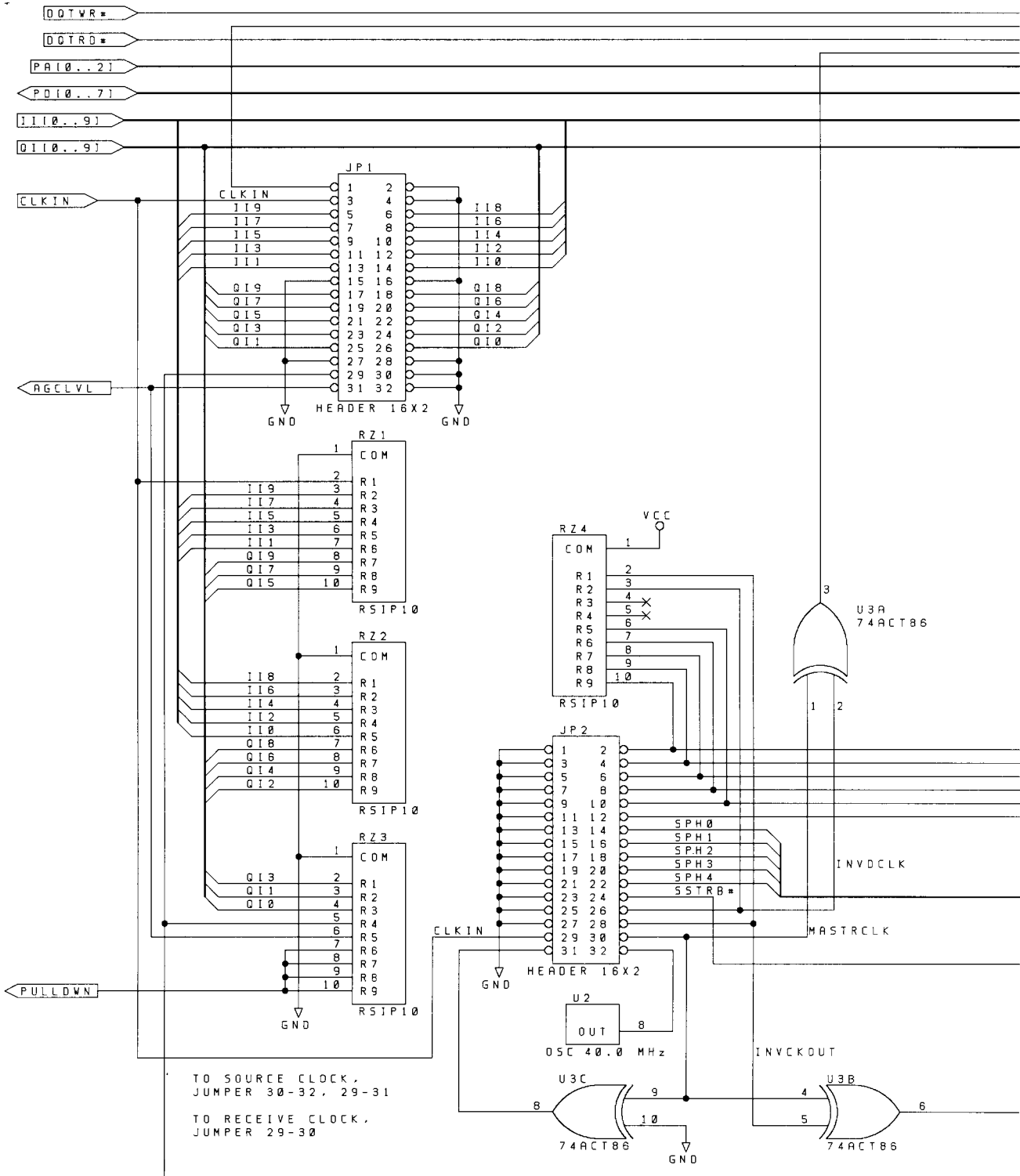

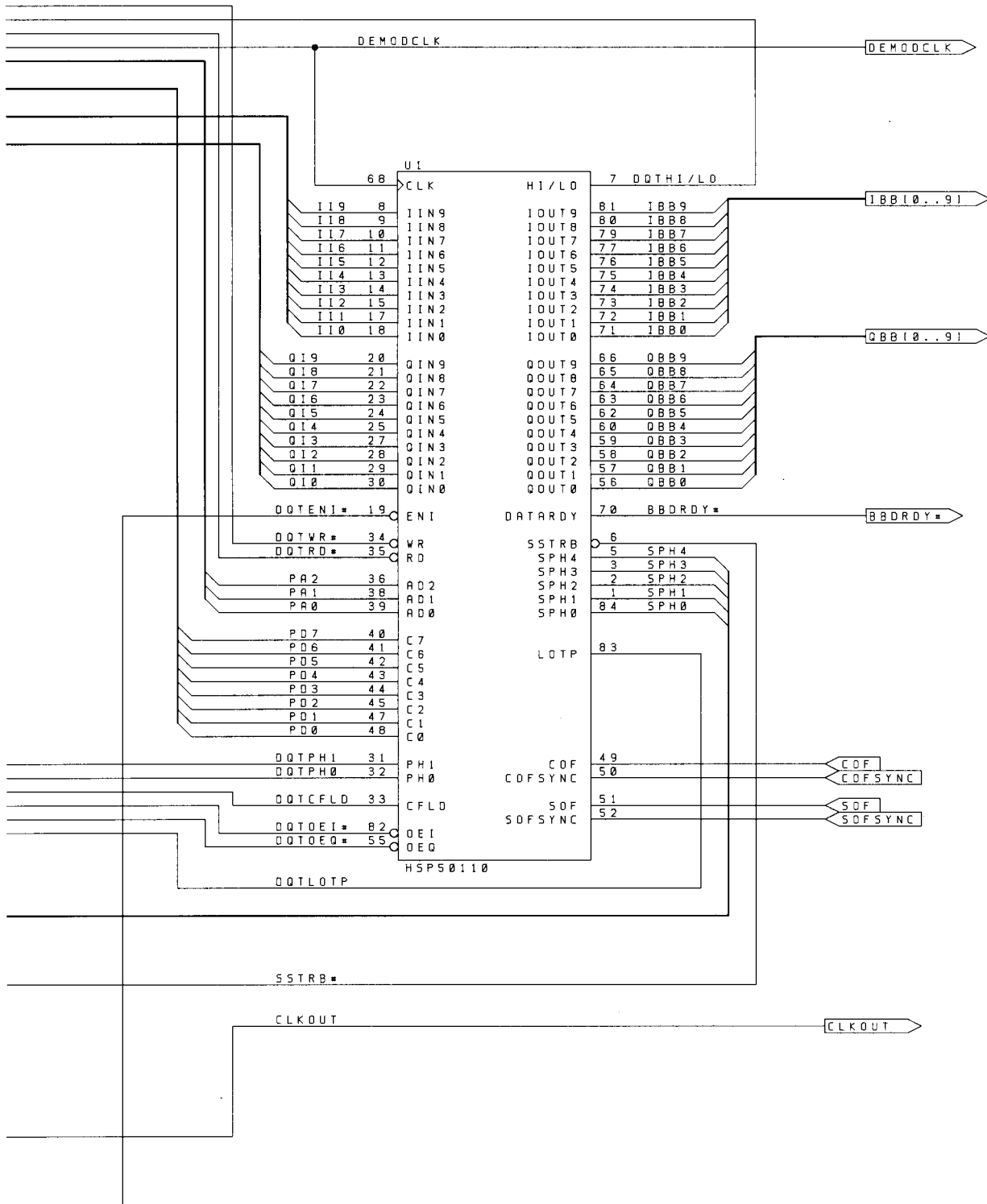

# HSP50110/210EVAL

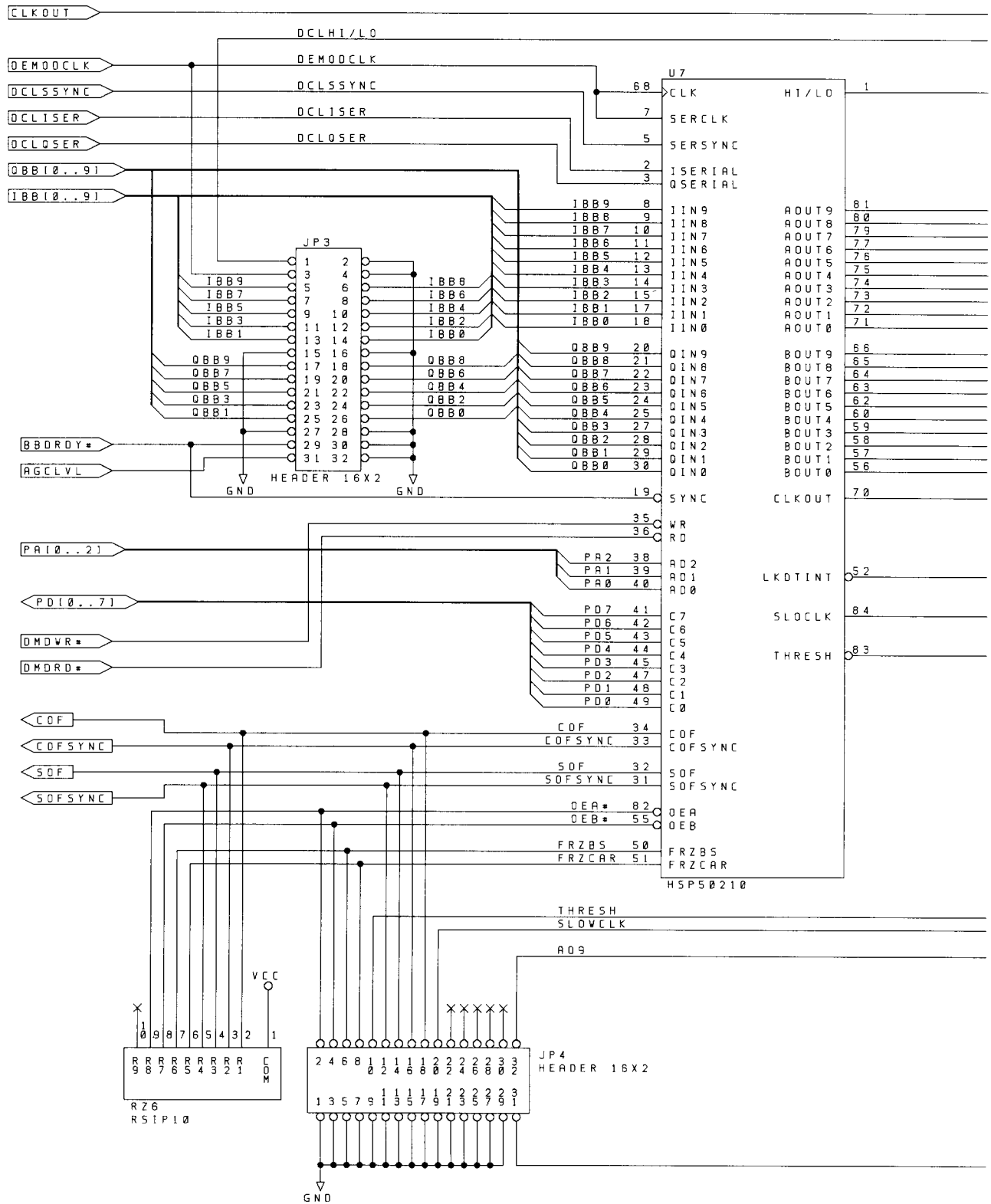

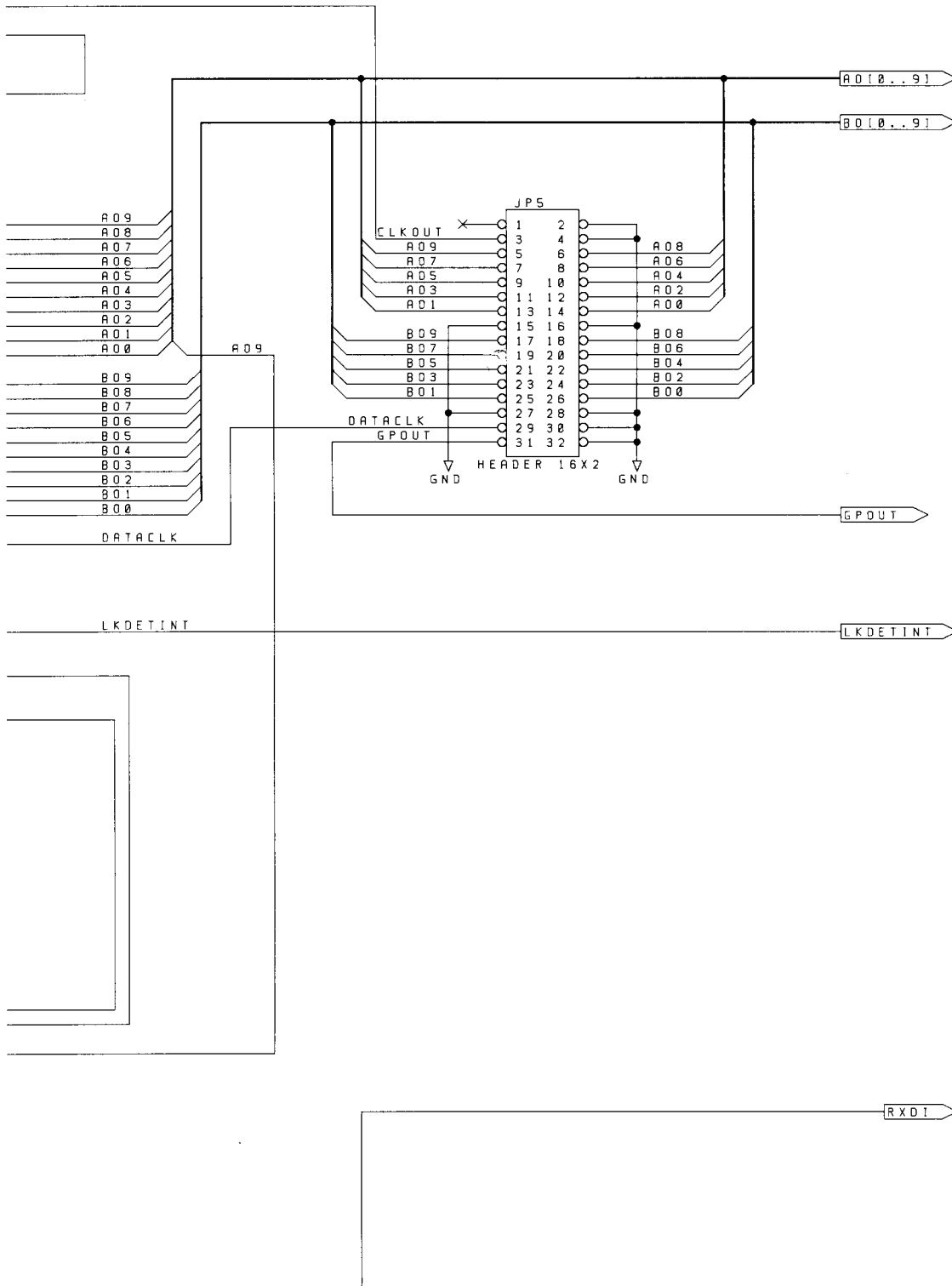

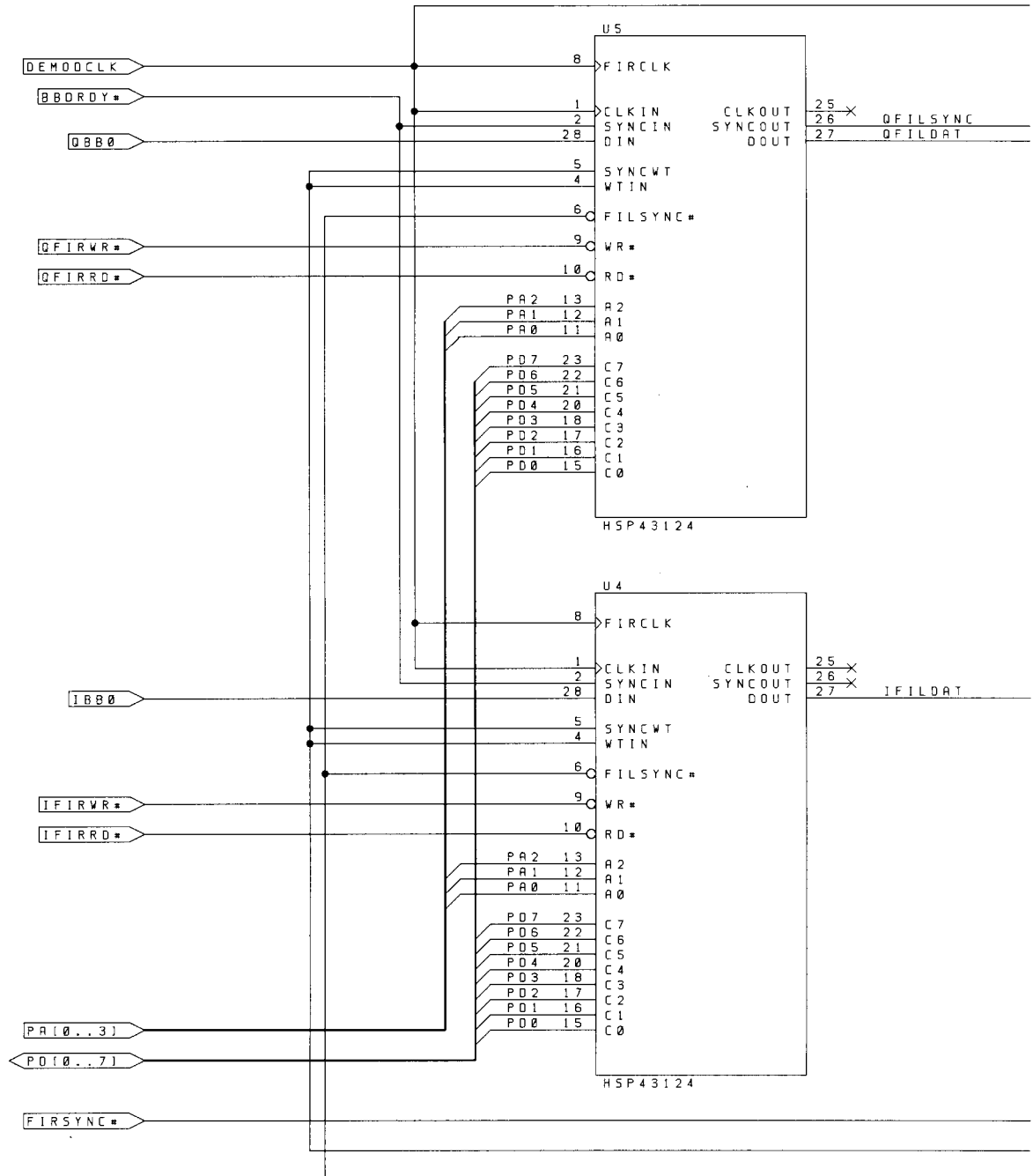

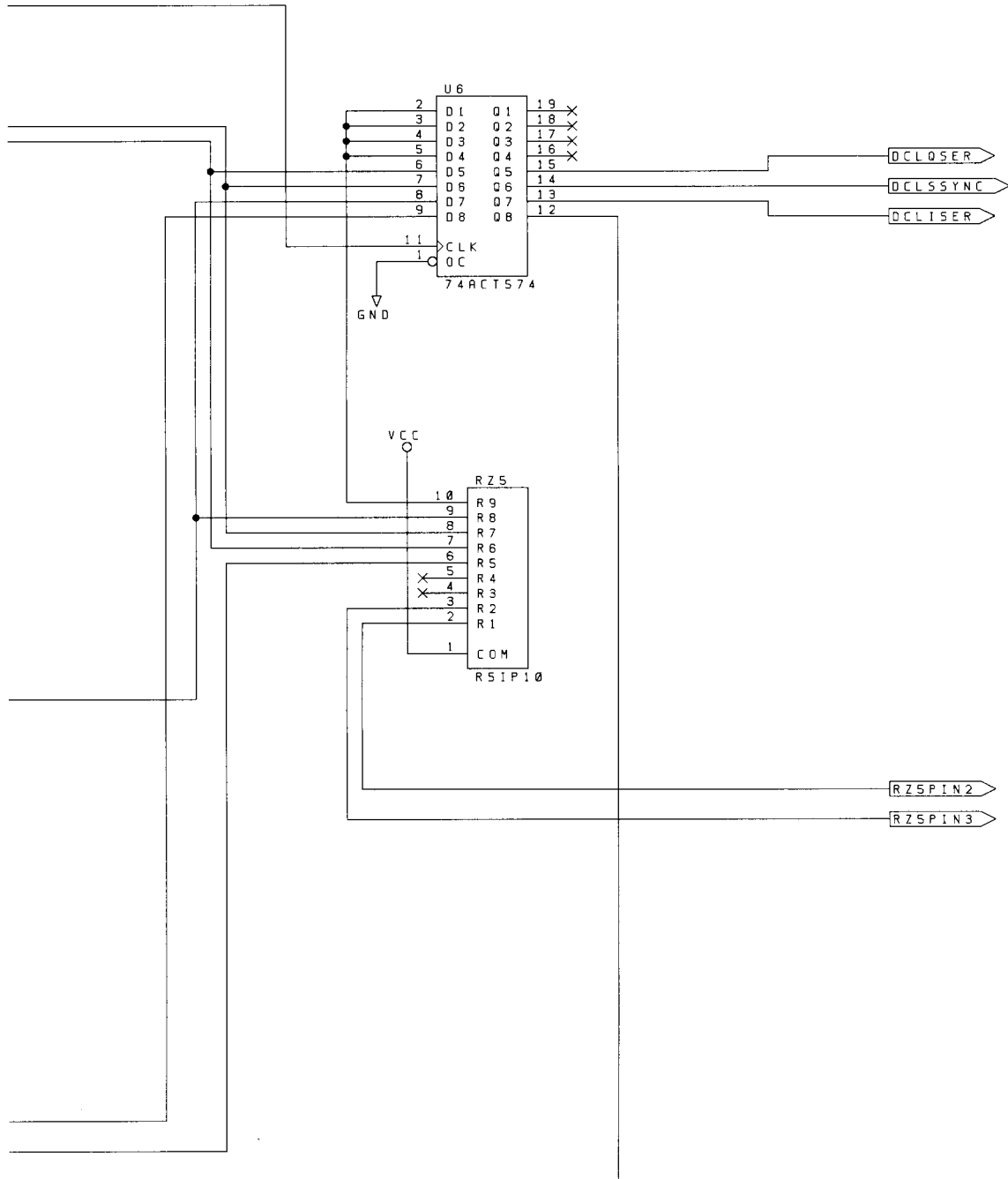

# HSP50110/210EVAL

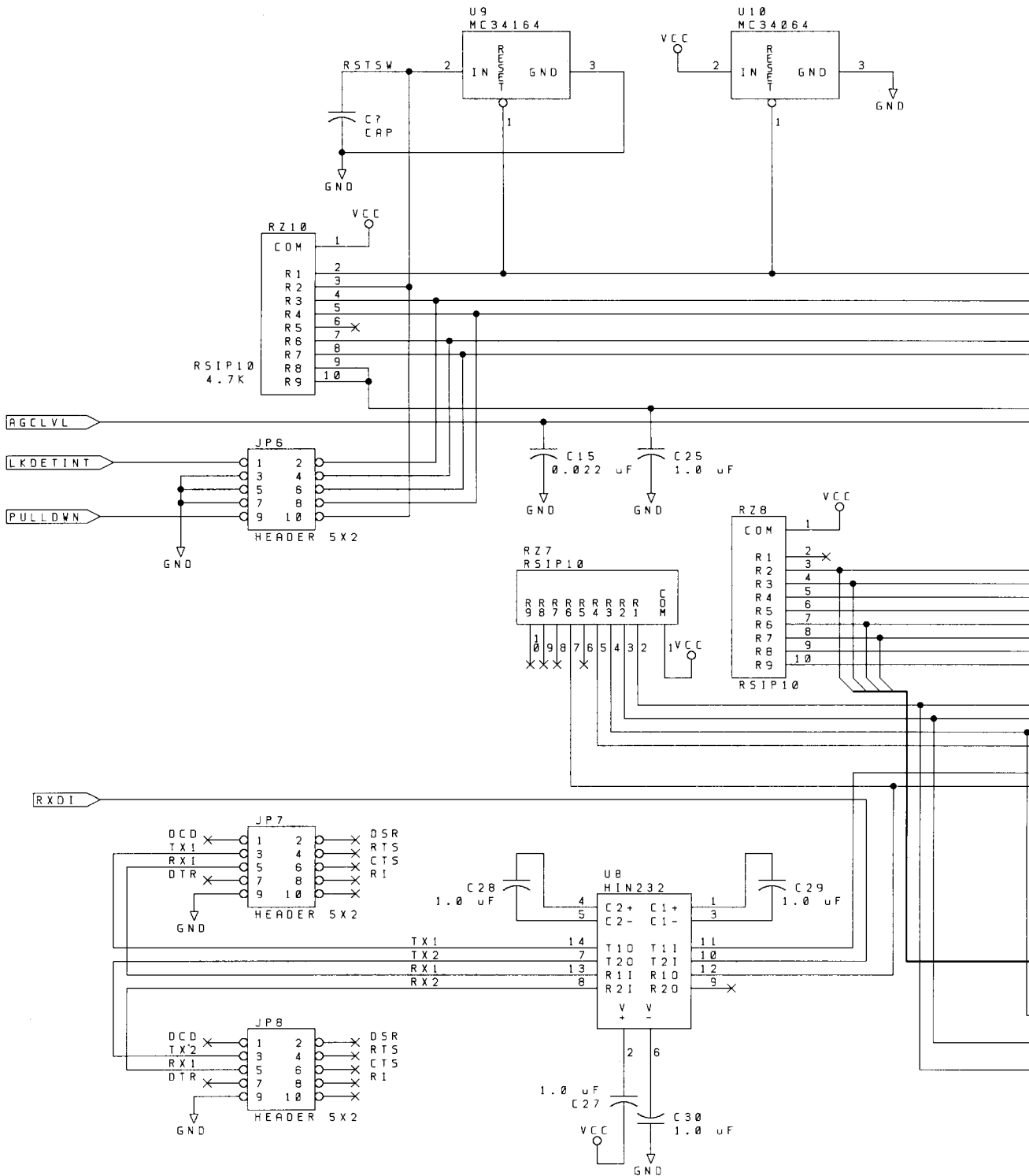

# HSP50110/210EVAL

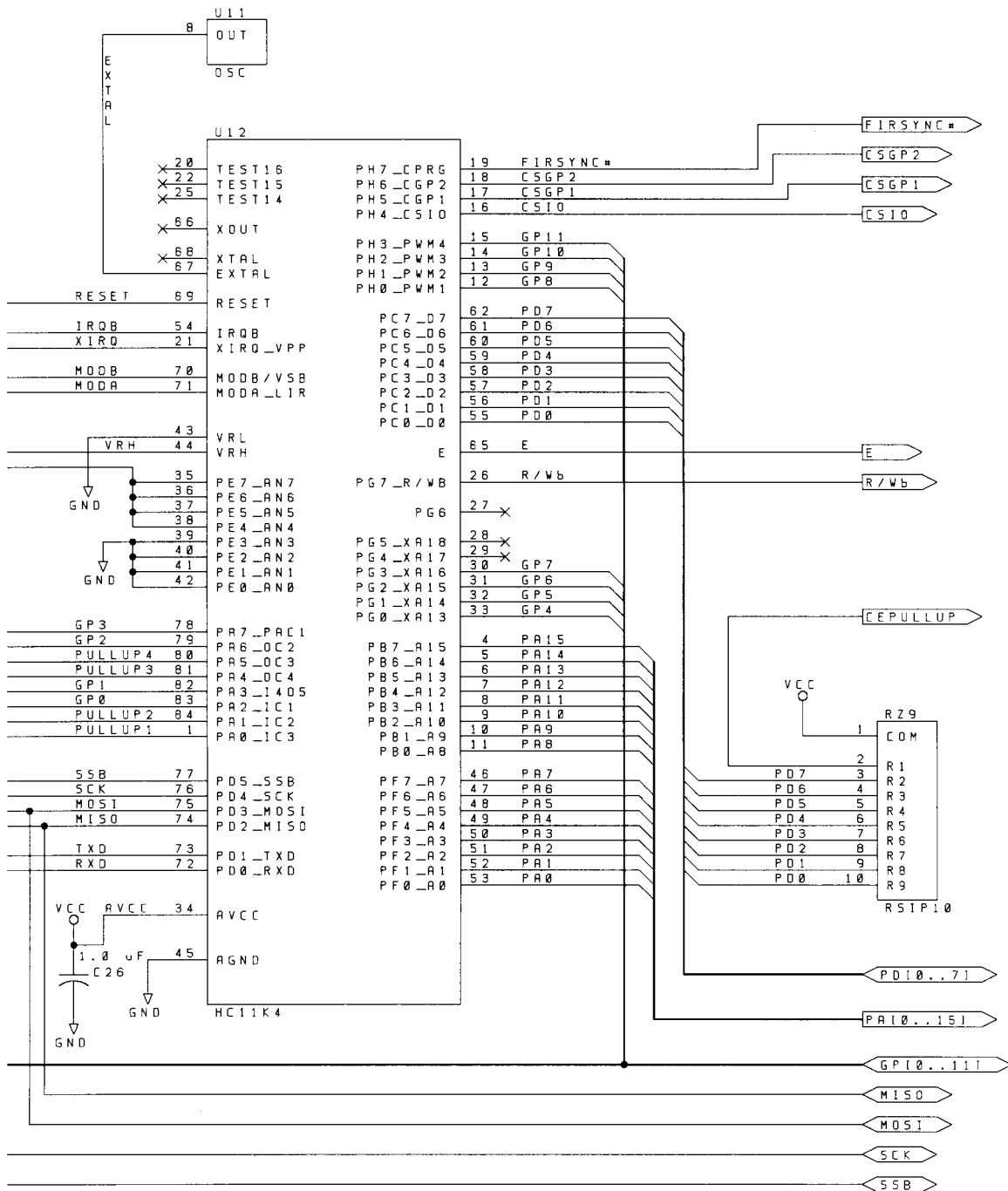



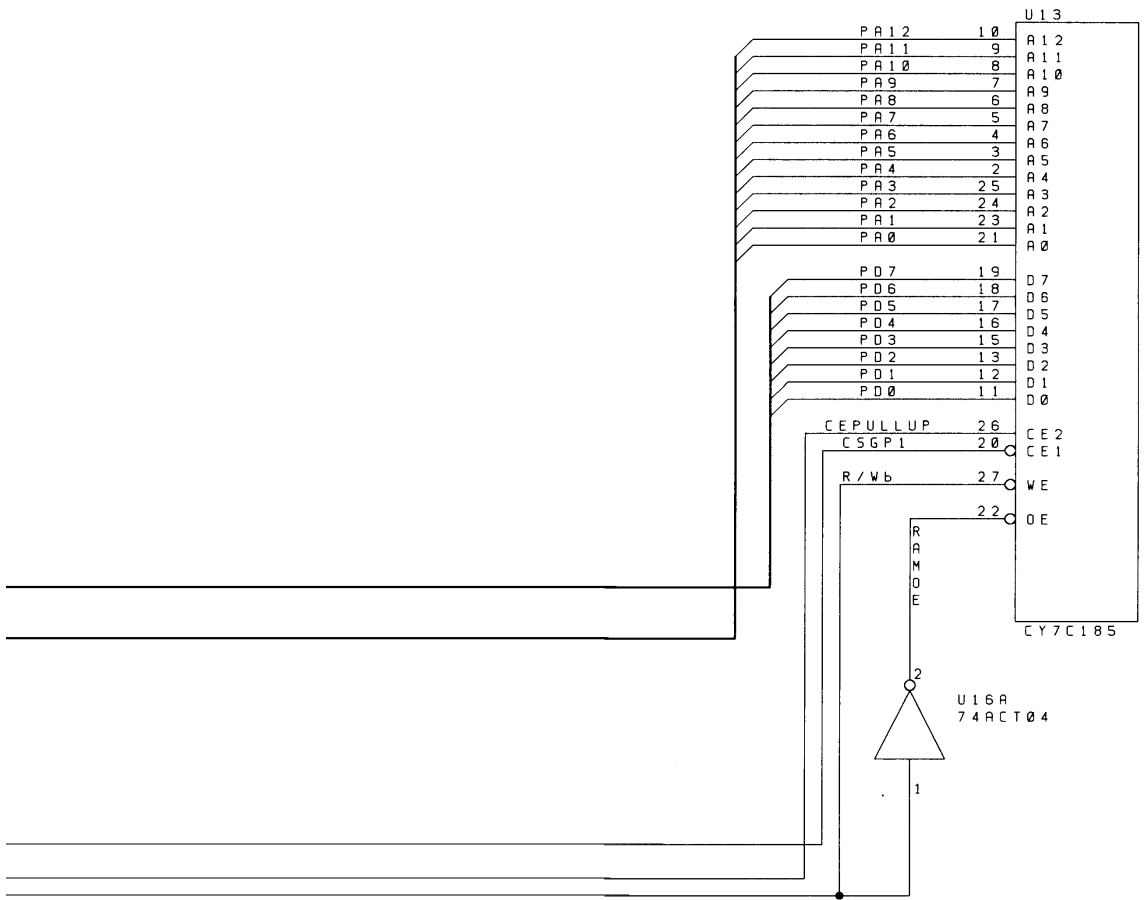
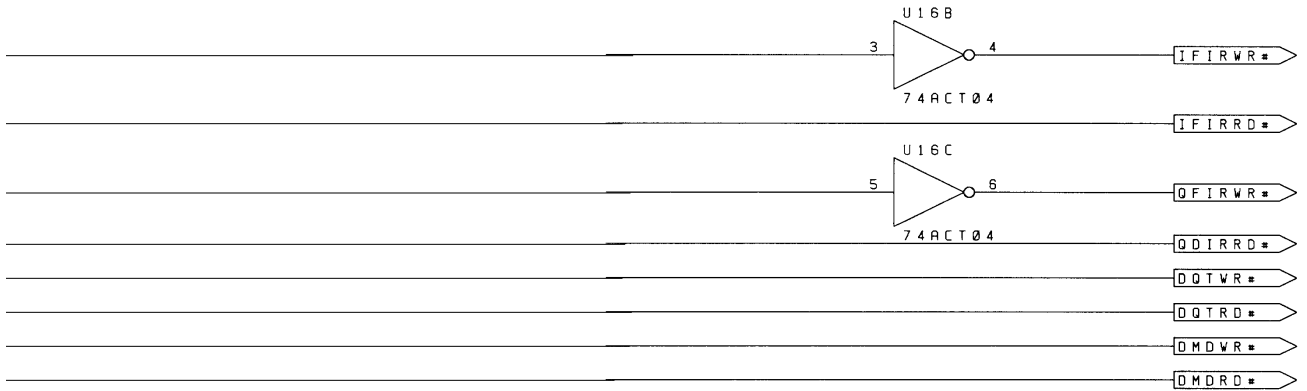

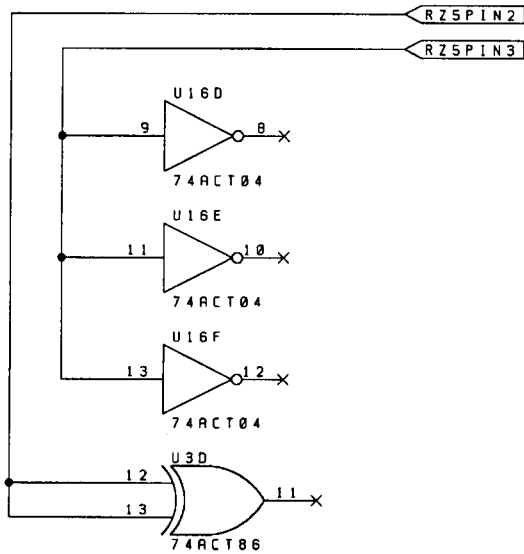
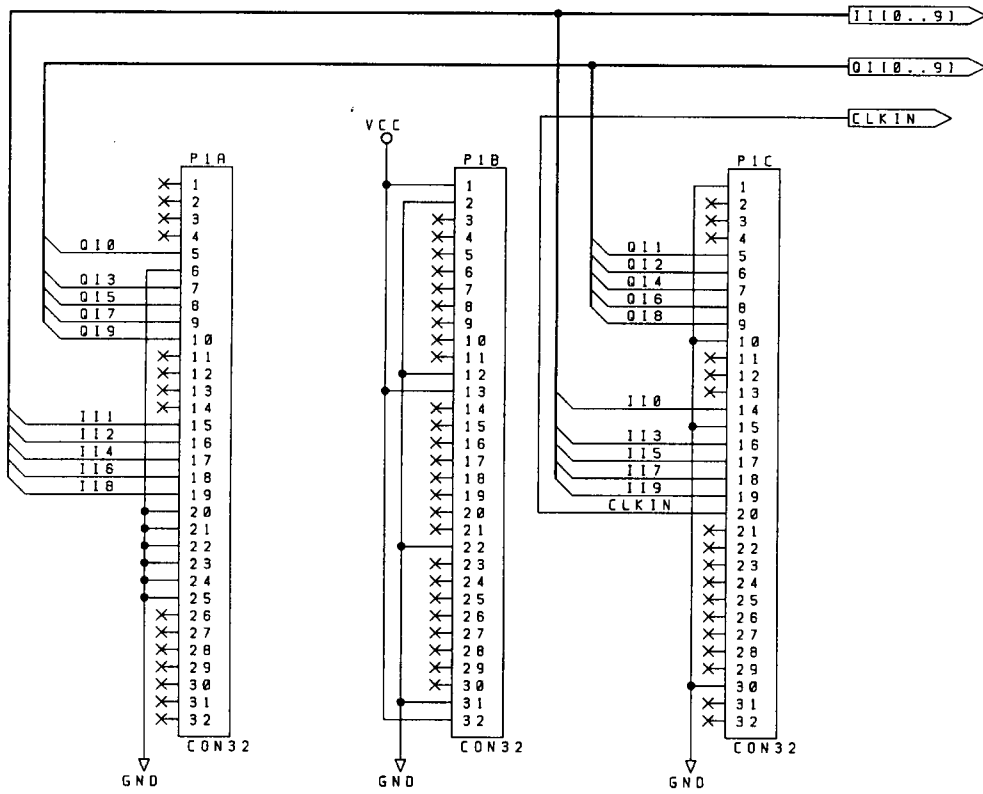

ILINK  
 ICHIPSET2.SCH  
 ICHIPSET3.SCH  
 ICHIPSET4.SCH  
 ICHIPSET5.SCH  
 ICHIPSET6.SCH

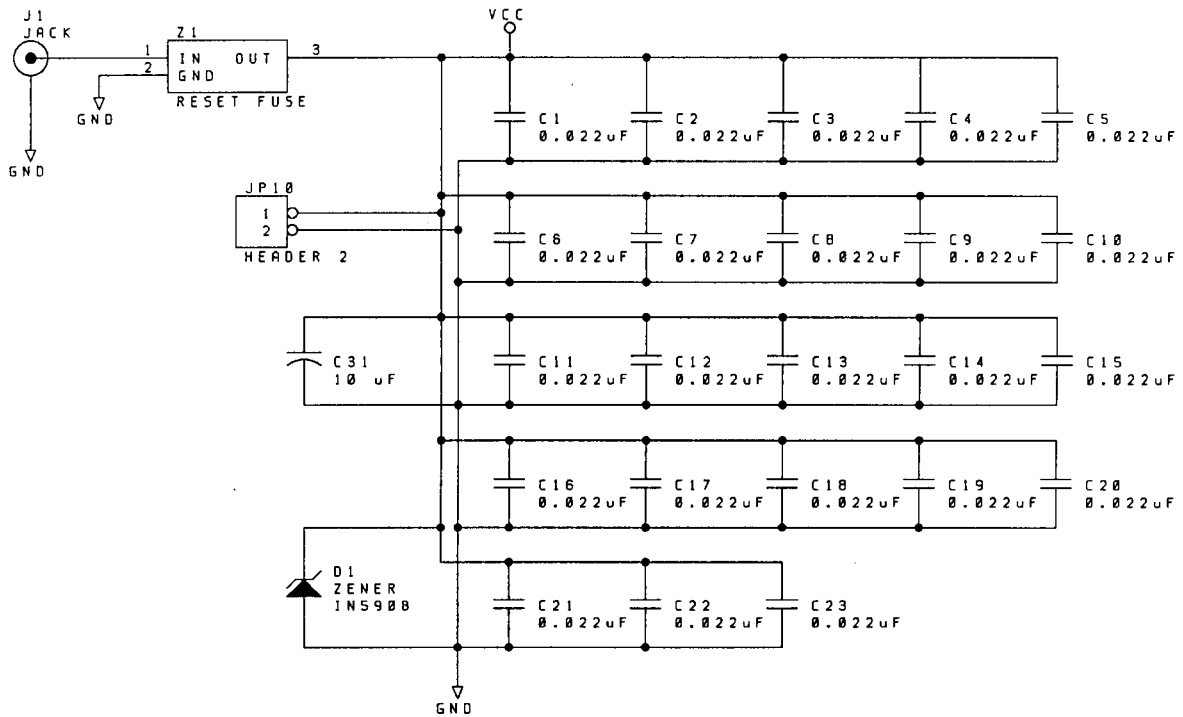
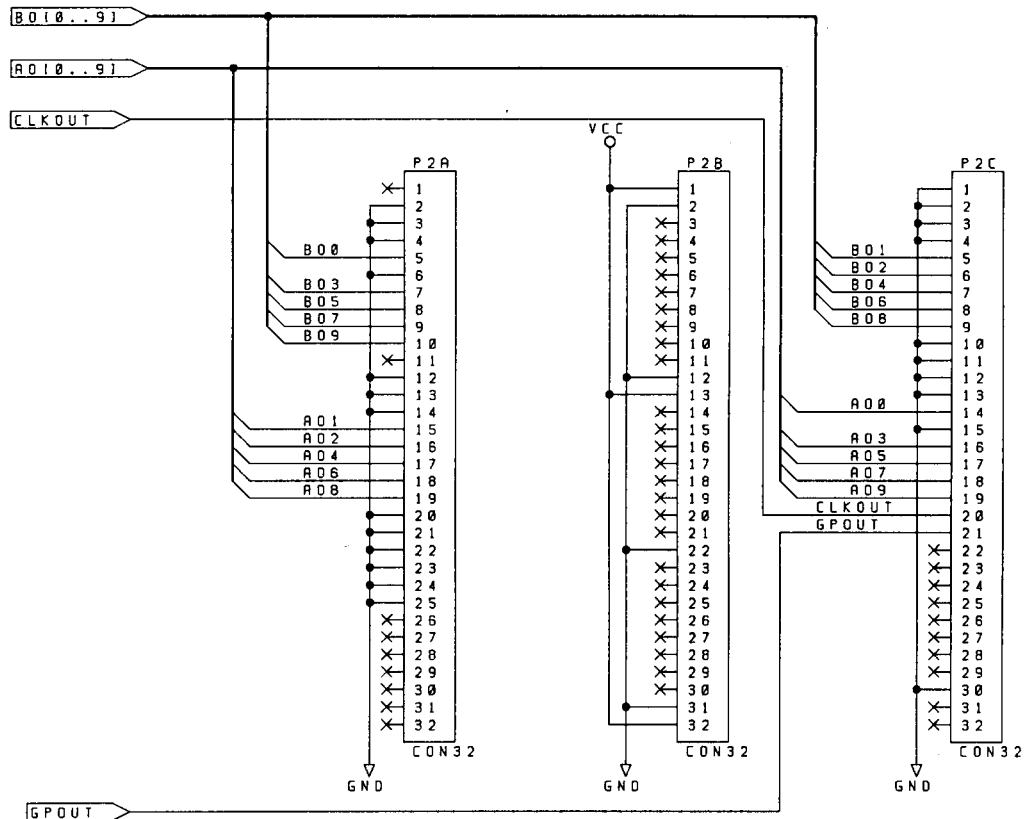

## HSP50110/210EVAL

### Appendix F

#### Parts List

#### EVALUATION CIRCUIT BOARD PARTS LIST

| ITEM | PART NUMBER     | TYPE      | DESCRIPTION   | MANUFACTURER | .REF DES   | QTY |
|------|-----------------|-----------|---|--------------|------------|-----|
| 1    | XC68HC711K4CFN4 | IC        | μProc   | MOTOROLA     | U12        | 1   |
| 2    | HSP50110JC-52   | IC        | Digital Quad Tuner  | INTERSIL     | U1         | 1   |
| 3    | HSP50210JC-52   | IC        | Digital Costas Loop   | INTERSIL     | U7         | 1   |
| 4    | HSP43124PC-45   | IC        | Serial I/O Filter   | INTERSIL     | U4, 5      | 2   |
| 5    | CD74ACT574E     | IC        | Octal Register  | INTERSIL     | U6         | 1   |
| 6    | IDT7164L20TP    | IC        | 8K x 8 SRAM   | IDT          | U13        | 1   |
| 7    | CD74ACT04E      | IC        | Hex Inverter  | INTERSIL     | U16        | 1   |
| 8    | MC34064P-5      | IC        | Voltage Detector  | MOTOROLA     | U10        | 1   |
| 9    | MC34164P-5      | IC        | Voltage Detector  | MOTOROLA     | U9         | 1   |
| 10   | CD74ACT138E     | IC        | 3:8 Decoder   | INTERSIL     | U14, 15    | 2   |
| 11   | CD74ACT86E      | IC        | Quad XOR Gate   | INTERSIL     | U3         | 1   |
| 12   | HIN232CP        | IC        | 232 Transceiver   | INTERSIL     | U8         | 1   |
| 13   | CO6100-40.000   | IC        | OSC, 40MHz, 100ppm freq. stability† HCMOS 14 pin DIP. 40-60% symmetry<br>pin 14 - V <sub>CC</sub> , pin 8 - V <sub>OUT</sub> ,<br>pin 7 - GND, pin 1 - NC | RALTRON      | U2         | 1   |
| 14   | CO6100-8.000    | IC        | OSC, 8MHz, 100ppm freq. stability† HCMOS 14 pin DIP. 40-60% symmetry<br>pin 14 - V <sub>CC</sub> , pin 8 - V <sub>OUT</sub> ,<br>pin 7 - GND, pin 1 - NC  | RALTRON      | U11        | 1   |
| 15   | PTC05DAAN       | Conn      | 2 x 5 Pin Header  | SULLINS      | JP6, 7, 8  | 3   |
| 16   | PTC30DAAN       | Conn      | 2 x 30 Pin Header   | SULLINS      | JP9        | 1   |
| 17   | PTC25DAAN       | Conn      | 2 x 25 Pin Header   | SULLINS      | JP1-5      | 5   |
| 18   | 510AG91D20ES    | Socket    | SIP Socket, 20 Pin  | AUGAT        | XU4, 5, 13 | 6   |
| 19   | 814-AG11D       | Socket    | DIP Socket, 14 Pin  | AUGAT        | XU2, 11    | 2   |
| 20   | 821573-1        | Socket    | 84 PLCC   | AMP          | XU1, 7, 12 | 3   |
| 21   | 4610X-101-472   | RPACK     | 4.7K RPack 10 Pin SIP   | BOURNS       | RZ10       | 1   |
| 22   | 4610X-101-223   | RPACK     | 22K RPack 10 Pin SIP  | BOURNS       | RZ1-9      | 9   |
| 23   | A223M15Z5UFVWVE | Cap, CER  | 0.022μF, 50V  | PHILIPS      | C1-23      | 23  |
| 24   | ECS-F1VE105K    | Cap, Tant | 1.0μF, 25V  | PANASONIC    | C24-30     | 7   |
| 25   | ECS-F1VE106K    | Cap, Tant | 10μF, 35V   | PANASONIC    | C31        | 1   |
| 26   | 1N5908          | Diode     | Zener 5V  | MOTOROLA     | D1         | 1   |
| 27   | DJ005           | Conn      | Jack  | LZR          | J1         | 1   |
| 28   | RUE135          | Fuse      | Reset Fuse 1.35/2.7A  | RAYCHEM      | Z1         | 1   |
| 29   | PTC01DAAN       | Conn      | 2 Pin Power Term  | SULLINS      | JP10       | 1   |
| 30   | C1AXG-1036M-ND  | Conn      | 10 Pin Ribbon W/ Conn   | DIGIKEY      |            | .1  |
| 31   | CFG09G-ND       | Cable     | 9 Pin D Conn (Female)   | DIGIKEY      |            | 1   |
| 32   | S9000-ND        | Jumper    | Shorting Jumpers  | DIGIKEY      |            | 25  |
| 33   | 650473-5        | Conn      | 96 Pin RT Angle, Plug   | AMP          | P1, 2      | 2   |
| 34   | HSP5011B        | PWB       | Printed Circuit Card  |              |            | 1   |
| 35   | DC10B           | Cable     | Power Cable   | LZR          |            | 1   |

† Frequency stability inclusive of room temperature, temperature stability over 0°C to 70°C, power supply variation, aging, shock and vibration.

## Appendix G

### Memory Maps

**HARDWARE AND SOFTWARE  
MEMORY MAP**

| FIRST ADDR                 | LAST ADDR | DESCRIPTION   |
|----------------------------|-----------|---|
| 0000                       | 007F      | 68HC11 Configuration Registers                          |
| 0080                       | 02FF      | 68HC11 Internal RAM B                                   |
| 0300                       | 037F      | 68HC11 Internal RAM A                                   |
| 0D80                       | 0FFF      | 68HC11 Internal EEPROM                                  |
| HARDWARE ADDRESS DECODER 1 |           |   |
| 1400                       | 14FF      | IFIR (HSP43124)<br>(1400-1407 R/W)                      |
| 1500                       | 15FF      | QFIR (HSP43124)<br>(1500-1507 R/W)                      |
| 1600                       | 16FF      | DQT (HSP50110)<br>(1600-1604 W, 1600 R)                 |
| 1700                       | 17FF      | DCL (HSP50210)<br>(1700-1705 W, 1700-1704 R)            |
| HARDWARE ADDRESS DECODER 2 |           |   |
| 2000                       | 21FF      | WRSTRB1 (on JP9)  |
| 2200                       | 23FF      | WRSTRB2 (on JP9)  |
| 2400                       | 27FF      | WRSTRB3 (Not Connected)                                 |
| EXTERNAL RAM (8K BYTES)    |           |   |
| 4000                       | 5FFF      | RAM   |
| 68HC11 INTERNAL EPROM      |           |   |
| A000                       | CFFF      | Unused  |
| D000                       | FFFF      | MOTOROLA BUFFALO<br>Monitor Program<br>(Version BUFK42) |

**RAM USAGE BY DEMODEV.B.EXE PROGRAM  
(2352/8192 BYTES USED)**

| ADDRESS   | DESCRIPTION                       |
|-----------|-----------------------------------|
| 4000-41FF | IFIR Coefficients                 |
| 4200-4207 | IFIR Registers                    |
| 4208-42FF | Unused (248 Bytes)                |
| 4300-44FF | QFIR Coefficients                 |
| 4500-4507 | QFIR Registers                    |
| 4508-45FF | Unused (248 Bytes)                |
| 4600-467F | DCL Registers 00-31d<br>MSB FIRST |
| 4680-46FF | Unused (128 Bytes)                |
| 4700-471F | DQT Registers 00-07<br>MSB First  |
| 4720-47FF | Unused (224 Bytes)                |
| 4800-4FFF | Unused (2048 Bytes)               |
| 5000-502F | DQT Write Program                 |
| 5030-50FF | Unused (192 Bytes)                |
| 5100-51B2 | DCL Write Program                 |
| 51BF-51FF | Unused (64 Bytes)                 |
| 5200-526  | IFIR Write Program                |
| 5270-52FF | Unused (144 Bytes)                |
| 5300-536F | QFIR Write Program                |
| 5370-53FF | Unused (144 Bytes)                |
| 5400-546F | DCL Status Program                |
| 5680-569F | Status Registers                  |
| 56A0-5FFF | Unused (2400 Bytes)               |

**68HC11 CONFIGURATION REGISTER  
PROGRAMMING**

| ADDR | NAME   | DATA | COMMENT   |
|------|--------|------|---|
| 005A | CSCTR  | 00h  | No CS Cycle Stretching                                    |
| 005B | CSCTL  | 88h  | EN, Active Low, Sync to E, 4K Block GP Priority, Bit 7 GP |
| 005C | GPCS1A | 08h  | Address Start at 4000h                                    |
| 005D | GPCS1C | 03h  | No CS Interaction, Active Low, Sync TO E, 8K Block        |
| 005E | GPCS2A | 04h  | Address Start at 2000h                                    |
| 005F | GPCS2C | 01h  | No CS Interaction, Active Low, Sync TO E, 2K Block        |

**Appendix H**

**Descriptive File List**

**PC PROGRAM**

| FILE          | DESCRIPTION             |
|---------------|-------------------------|
| DEMODEV.B.EXE | Compiled Program for PC |

**68HC11 FILES AND PROGRAMS**

| FILE                     | DESCRIPTION  |
|--------------------------|--|
| INIT.S                   | Download to Initialize the 6811 (Define Ports, Map Memory, etc.)                                   |
| DQTWRITE.S               | 6811 Program to Transfer Registers to the HSP50110   |
| DCLWRITE.S               | 6811 Program to Transfer Registers to the HSP50210   |
| DCLSTAT.S                | 6811 Program to Get Status From the HSP50210   |
| IFIRWRIT.S               | 6811 Program to Transfer Coefficients to the HSP43124 (I Channel)                                  |
| QFIRWRIT.S               | 6811 Program to Transfer Coefficients to the HSP43124 (Q Channel)                                  |
| IFIRREGS.S               | S-Record File, Generated by DMDEVAL4.EXE, Containing Register Values for the HSP43124 (I channel)  |
| QFIRREGS.S               | S-Record File, Generated by DMDEVAL4.EXE, Containing Register Values for the HSP43124 (Q Channel)  |
| IFIRCOEF.S<br>QFIRCOEF.S | S-Record File, Generated by DMDEVAL4.EXE, Containing Coefficients for the HSP43124 (Both Channels) |

**PROGRAM EXECUTION**

| FILE   | DESCRIPTION  |
|--------|--|
| FILENM | Holds File Prefix for Last Configuration Saved. Loaded on Start-up/modified On Save                                  |
| *.CFG  | Holds Menu items for Setup. Loaded by Program When a New File is Selected (and on Start Up Using the File in FILENM) |
| *.DLD  | Holds 6811 Monitor Commands to Download to 50110 and 50210   |
| *.ARY  | Listing of Register Values for 50110 and 50210   |
| *.RPT  | Output File from SERINADE Filter Design Program. Used to Generate Coefficient Download Files                         |

**MISCELLANEOUS**

| FILE            | DESCRIPTION   |
|-----------------|---|
| B128RRC. (Note) | Example File 128k symbols/sec, BPSK, and RRC filtering. |
| NOTES.TXT       | Notes On Using The Eval Board and Program               |
| HC11MMAP.TXT    | Memory Map of Eval Board (Including Program RAM Usage)  |

NOTE: Only one of many example files. The naming convention for these files is:

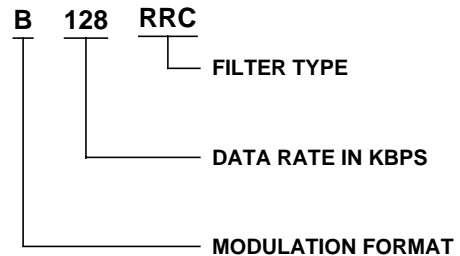

Modulation Formats: BPSK, QPSK, 8PSK  
 Data Rates: 1p2 to 2500  
 Filter Types: RRC, I&D, FIR

## Appendix I

### Detailed Menu Item Descriptions

#### DATA PATH/MODULATION MENU

##### Item 1: Master Clock Frequency [clockfreq]

(1,000Hz to 52,000,000Hz)

Enter the frequency of the external reference input clock, or 40,000,000Hz as the frequency of the on-board oscillator. Make sure that the evaluation board is configured for external clock before the external clock is applied to the board.

##### Item 2: Input Sample Rate [fsamp]

(1,000Hz to 52,000,000Hz)

The input sample rate is the rate that the HSP50110  $\overline{\text{ENI}}$  Pin (JP1-29) is asserted. In interpolated mode, this should be an integer submultiple of the master clock. In gated mode, this is the rate the carrier and bit sync NCOs in the 50110 are updated; in interpolated mode, this is the rate that the carrier NCO is updated--the bit sync NCO is updated at the master clock rate. The carrier NCO in the 50210 always updates at the master clock rate.

##### Item 3: Input Mode [inmode]

(0; 1)

Gated = 0; Interpolated = 1.

When the input mode is gated, the new data is processed when  $\overline{\text{ENI}}$  is asserted. Pipelining is done at the master clock rate. When the input mode is interpolated, new samples are input when  $\overline{\text{ENI}}$  is asserted, zeros are inserted between these samples, and the processing is done at the master clock rate.

##### Item 4: DQT Input Samples [rlcmplx]

(0; 1)

Complex = 0; real = 1

If a real input is used (either I or Q only), the unused input bus should be tied to midscale external to the HSP50110. This will be 200h if the input format is offset binary and 0 if it is 2s complement

##### Item 5: DQT Input Format [dqtfmfmt]

(0; 1)

0 = Twos Complement

1 = Offset Binary

##### Item 6: Carrier Center Freq [ccf]

(-52,000,000Hz to 52,000,000Hz)

The carrier L.O. center frequency is interpreted as two's complement, so it can be a positive or negative frequency and select either the upper or lower sideband of a real input signal.

##### Item 7: Data Modulation [modtype]

(0; 1; 2; 3; 4)

0 = off, 1 = BPSK, 2 = QPSK, 3 = OQPSK, 4 = 8PSK

##### Item 8: Baud Rate [brate]

(1 to 56,000,000 Symbols/s)

This is the output symbol rate of the HSP50210. Note that entering a value greater than one half the clock rate induces excessive aliasing.

##### Item 9: DQT Output Rate [dqtoutrate]

(1 to 56,000,000 Samples/s)

This is the output sample rate of the HSP50110. It will be a multiple of baud rate and depends on the decimation following the HSP50110. If the integrate and dump filtering in the HSP50210 is enabled, the HSP50110 output rate will be N times the baud rate where N is the number of samples integrated. If the integrate and dump filtering is not used (and no external filtering is used), the input rate to the HSP50210 should be 2x the baud.

##### Item 10: I.F. Noise Bandwidth [ifnbw]

(1Hz to 26,000,000Hz)

This is the noise bandwidth of the I.F. filtering preceding the HSP50110. This is used to compute the gain needed to compensate for the change in SNR from the A/D to the matched filtering.

##### Item 11: DQT Filtering [dqtfilt]

(0; 1; 2; 3; 4; 5)

0 = Bypass, 1 = I&D, 2 = 3CIC, 3 = I&D w/ comp, 4 = 3CIC w/ comp, 5 = X/SinX

##### Item 12: DCL RRC Filter [dclrrcfilt]

(0; 1) 0 = Bypass; 1 = Enable

The root raised cosine in the HSP50210 should be enabled if it is the matched filter for the data. It should be bypassed if the matched filtering is done in the HSP43124 FIR filters. It can be enabled for out-of-band signal filtering and SNR improvement when integrate-and-dump filtering over 2 or 4 samples is used. (Some degradation will be seen with integration over 2 or 4 samples and the RRC filter enabled).

##### Item 13: DCL I&D Filtering [dclidmrate]

(0; 1; 2; 3; 4; 5)

Value  $0 <= N <= 5$ ; ( $2^N$  samples integrated)

##### Item 14: HSP43124 Serial Filter Enable [sfen]

(0; 1)

0 = HSP43124 filters bypassed

1 = HSP43124 filters enabled

(user is then prompted for a file prefix

prefix.RPT extension assumed)

**Item 15: Minimum Es/No [esnomin]**

(-100dB to 100dB)

Enter the minimum Es/No expected. This is used to set the data path maximum gain.

**Item 16: Maximum Es/No [esnomax]**

(-100dB to 100dB)

Enter the maximum Es/No expected. This is used to set the data path minimum gain. Enter 100 for noise free.

**Item 17: Design Es/No [esnodes]**

(-100dB to 100dB)

Enter the design Es/No. This is used to set the carrier phase detector operational gain. Enter 100 for noise free.

**Item 18: Minimum A/D Backoff [adbackoffmin]**

(0 to 60)

This is the minimum total power backoff at the A/D. The nominal backoff is halfway between the minimum and max backoff.

**Item 19: Maximum A/D Backoff [adbackoffmax]**

(0 to 60)

This is the maximum total power backoff at the A/D.

**Item 20: DCL Output Vector Length [dcloutlvl]**

(-60 to 3)

This is the nominal HSP50210 output level set by the AGC. This is in dB relative to full scale on either axis. Typically, this is set to -6dB for BPSK, -3dB for QPSK, and -1.8dB for 8PSK.

**Item 21: DQT Output Vector Level [dqtoutlvl]**

(-60 to 3)

The output level for the HSP50110 is set to minimize limiting while maximizing effective bits. With noise only, this is typically set to -12dBFS. Since the HSP50210 can only add gain and cannot attenuate a signal, this should be set low enough that the output level at the HSP50210 can be achieved (for example, the HSP50110 output should not be set to -6dBFS when the desired output of the HSP50210 is -6dBFS).

**Item 22: DCL Output Level Detector Threshold [outdetlvl]**

(-60 to 3)

This is the threshold for the output level detector on the HSP50210 ( $\overline{\text{THRESH}}$ ). The output pin is asserted when the signal magnitude out of the HSP50210 exceeds this programmed threshold.

**Item 23: Output Slicer Threshold [slcrthr]**

(0 to 1)

The output slicer thresholds are set based on the needs of the FEC. The programmed level is the first of the three comparator thresholds. The thresholds are relative to the full scale magnitude on one rail. The output format set by the program for the soft decisions is currently signed-magnitude. The range is 0-1. The decisions thresholds are at 1x, 2x, 3x the programmed threshold.

**Item 24: DQT AGC Slew Rate [dqtagcslew]**

(0 to 1,000,000)

This is the slew rate for the AGC in the HSP50110. The AGC is updated on every output sample. Since this AGC adjusts for changes that are out of the band of interest (FDM signals coming and going, etc.), it is typically set to slew faster than the AGC in the HSP50210. The value entered is in dB/s

**Item 25 DCL AGC Slew Rate [dclagcslew]**

(0 to 1,000,000)

This is the slew rate for the AGC in the HSP50210. This AGC adjusts for changes in signal level due to SNR changes or signals coming and going inside the filter band of the HSP50110. This AGC is typically set to slew slower than the AGC in the HSP50110. The value entered is in dB/sec.

**Item 26: AGC Limits [agclimcalc]**

(0; 1)

0 = Computed; 1 = FULL RANGE

This value is either calculated from the bandwidths and Es/No's, or is entered as FULL RANGE.

**Item 27: Output Multiplexer Control [outmux]**

(0; 1; 2; 3; 4; 5; 6; 7, 8)

- 0 - Isoft(2:0), Qsoft(2:0), Status(6:0), AGC(7:1)
- 1 - Isoft2, Qsoft2, Mag(7:0), Status6, Status0, Phase(7:0)
- 2 - Isoft(2:0), Qsoft(2:0), Status(6:0), FreqErr(7:1)
- 3 - Isoft(2:0), Qsoft(2:0), Status(6:0), GainErr(7:1)
- 4 - Isoft(2:0), Qsoft(2:0), Status(6:0), BitPhErr(7:1)
- 5 - Isoft(2:0), Qsoft(2:0), Status(6:0), CarPhErr(7:1)
- 6 - Isoft(2:0), Qsoft(2:0), LkAcc(6:0), LkCnt(6:0)
- 7 - Isoft(2:0), Qsoft(2:0), lend(7:1), Qend(7:1))
- 8 -Reserved(7:0), Status5, Status6, NCOS(9:0)

The output multiplexer selects the signals that are routed to the output bus of the HSP50210. In most cases, the soft decisions are available at the MSBs of the AOUT bus. This allows other nodes to be monitored without disturbing the output data. In most cases where an error detector is brought out, it is the bottom 7 bits of the BOUT bus. Selection 7 can be used to plot the I/Q constellation using a logic analyzer or a pair of D/A converters.

**CARRIER TRACKING LOOP MENU**

**Item 1: Carrier Tracking Loop Upper Limit [carul]**

(-52,000,000Hz to 52,000,000Hz)

This is the upper limit for carrier loop filter lag accumulator. This sets the upper limit on carrier acquisition and tracking. During acquisition, the sweep direction reverses when this limit is reached.

**Item 2: Carrier Tracking Loop Lower Limit [carll]**

(-52,000,000Hz to 52,000,000Hz)

This is the lower limit for carrier loop filter lag accumulator. This sets the lower limit on carrier acquisition and tracking. During acquisition, the sweep direction reverses when this limit is reached.

**Item 3: Carrier Tracking Loop Order [ctlorder]**

(0; 1; 2)

0 = disabled, 1 = 1st, 2 = 2nd

When carrier tracking is disabled, the feedback path from the HSP50210 in the HSP50110 is disabled and the complex multiplier in the HSP50210 is bypassed. In first order mode, the phase error input to the carrier lag accumulator is zeroed. In second order mode, the loop filter is a lead/lag type. During acquisition, the program sets the loop to first order.

**Item 4: Carrier Acq. Fractional Loop Bandwidth [carlbwacq]**

(0.0 to 0.125)

This is the single-sided loop noise bandwidth used for acquisition. Enter the bandwidth desired at the design SNR (it will narrow as SNR decreases). Fractional loop bandwidth is the ratio of the loop bandwidth to the baud rate (or the rate that the loop filter is updated). For example a loop bandwidth of 1kHz at 100kbaud would have a FLBW of 0.01.

**Item 5: Carrier Tracking Fractional Loop Bandwidth [carlbwtrk]**

(0.0 to 0.125)

This is the single-sided loop noise bandwidth used for tracking. Enter the bandwidth desired at the design SNR (it will narrow as SNR decreases). Fractional loop bandwidth is the ratio of the loop bandwidth to the baud rate (or the rate that the loop filter is updated). For example a loop bandwidth of 1kHz at 100kbaud would have a FLBW of 0.01. The tracking bandwidth is used during lock verification.

**Item 6: Carrier Tracking Loop Damping Factor [cardamp]**

(0.0 to 1.5)

This damping factor is used for acquisition and tracking. Enter the damping desired at the design SNR

**Item 7: Carrier AFC Function Enabled [afcon]**

(0; 1)

0 = Off; 1 = On

This item enables/disables the frequency error term to the carrier loop lag accumulator during both acquisition and tracking. To enable only during acquisition or tracking, zero the AFC gain for the mode not wanted.

**Item 8: AFC Error Gain (Acquisition) [afcnacq]**

(0 to 26,000,000)

This is the gain for the frequency error term summed into the carrier lag accumulator. This is in Hz/Hz (i.e. if constant offset of 100Hz is measured and the gain is set to 100Hz/Hz, the lag accumulator will move by 10,000Hz during one second).

**Item 9: AFC Error Gain (Tracking) [afcntrk]**

(0 to 26,000,000)

This is the gain for the frequency error term summed into the carrier lag accumulator. This is in Hz/Hz (i.e. if constant offset of 100Hz is measured and the gain is set to 100Hz/Hz, the lag accumulator will move by 10,000Hz during one second).

**Item 10: Delay in AFC Discriminator (x Half Baud) [descdly]**

(0; 1; 2; 3; 4)

0 = 1 samples; 1 = 2 samples;

2 = 4 samples; 3 = 8 samples, and 4 = 16 samples

The frequency offset is calculated by differencing the carrier phase error after a delay (dp/dt). The delay is in half baud intervals (for this program). Longer delays give higher gains. Aliasing can occur in the detector if the filtering is not tight enough for the delay chosen. The delay can be set to 1, 2, 4, 8, or 16 samples (0.5, 1, 2, 4, or 8 baud intervals).

**Item 11: Acquisition Sweep Rate [swprate]**

(0Hz/baud to 1,000,000Hz/baud)

This is the amount that the lag accumulator is incremented each time the loop filter runs (during swept acquisition mode) or each time the lock detector times out (during stepped acquisition mode).

**Item 12: Carrier Tracking Bits To DQT [cartrkbits]**

(0; 1; 2; 3)

0 = 8, 1 = 16, 2 = 24, and 3 = 32 bits.

This is the number of bits of the offset frequency sent from the HSP50210 to the HSP50110. At higher data rates, fewer bits can be used since the ratio between the clock rate and the loop bandwidth can be lower. This allows for faster updates and less delay around the loop.

**Item 13: Carrier Tracking Mode [cartrkmode]**

(0; 1; 2)

0 = lead and lag terms to DQT

1 = lead to DCL, lag to DQT

2 = lead and lag terms to DCL

These tracking modes offer a trade-off between delay around the loop and how well the signal is kept centered in the filtering. Mode 0 has the longest delay around the loop; mode 1 has a shorter delay for the lead term, so wider loop bandwidths can be used while the signal is still centered in the filtering; mode 2 has the shortest delay and uses the HSP50110 as a fixed tuner. Mode 2 allows the widest loop bandwidths, but the carrier offset must be small relative to the baud rate.

#### Item 14: DCL Slow Serial Output Clock [dclserclk]

(2; 4; 8; 16)

If the frequency offset serial output from the HSP50210 is routed to a destination instead of the HSP50110 (a D/A, an NCO), the serial data can be output at a submultiple of the master clock. The master clock/slower clock selection is done in menu item 15. Options are Fclk/N where N = 2, 4, 8, or 16.

#### Item 15: Carrier Serial Output [caroutclk]

(0; 1)

If the frequency offset serial output from the HSP50210 is routed to a destination other than the HSP50110 (a D/A, an NCO), the serial data can be output at a submultiple of the master clock. The master clock/slower clock selection is done here, and the speed of the slower clock slow clock is selected in menu item 14. The options are: Fclk (the master clock) and serial clock.

### BIT SYNC LOOP MENU

#### Item 1: Bit Sync Loop Upper Tracking Limit [bsul]

(-26,000,000 to 26,000,000)

This is the upper limit for bit sync loop filter lag accumulator. This sets the upper limit on symbol acquisition and tracking.

#### Item 2: Bit Sync Loop Lower Tracking Limit [bsll]

(-26,000,000 to 26,000,000)

This is the lower limit for bit sync loop filter lag accumulator. This sets the lower limit on symbol acquisition and tracking.

#### Item 3: Bit Sync Loop Order [bsorder]

(0; 1; 2)

0 = disabled, 1 = 1st, 2 = 2nd

When symbol tracking is disabled, the feedback path from the HSP50210 in the HSP50110 is disabled. In first order mode, the phase error input to the bit sync lag accumulator in the loop filter is zeroed. In second order mode, the loop filter is a lead/lag type.

#### Item 4: Bit Sync Acquisition Fractional Loop Bandwidth [bslbwacq]

(0.0 to 0.125)

This is the single-sided loop noise bandwidth used for acquisition. Enter the bandwidth desired at the design SNR (it will narrow as SNR decreases). Fractional loop bandwidth is the ratio of the loop bandwidth to the baud rate (or the rate that the loop filter is updated). For example a loop bandwidth of 1kHz at 100kbaud would have a FLBW of 0.01.

#### Item 5: Bit Sync Tracking Fractional Loop Bandwidth [bslbwtrk]

(0.0 to 0.125)

This is the single-sided loop noise bandwidth used for tracking. Enter the bandwidth desired at the design SNR. Fractional loop bandwidth is the ratio of the loop bandwidth to the baud rate (or the rate that the loop filter is updated). For example a loop bandwidth of 1kHz at 100kbaud would have a FLBW of 0.01.

#### Item 6: Bit Sync Loop Damping Factor [bsdamp]

(0.0 to 1.5)

This damping factor is used for acquisition and tracking. Enter the damping desired at the design SNR.

#### Item 7: Symbol Tracking Bits [bstrkbits]

(0; 1; 2; 3)

0 = 8, 1 = 16, 2 = 24, and 3 = 32.

This is the number of bits of the offset frequency sent from the HSP50210 to the HSP50110. At higher data rates, fewer bits can be used since the ratio between the clock rate and the loop bandwidth can be lower. This allows for faster updates and less delay around the loop.

#### Item 8: Bit Sync Serial Output Clock [bsoutclk]

(0; 1)

0 = Fclk (master clock);

1 = Serial clock (the SLOCLK output pin)

If the frequency offset serial output from the HSP50210 is routed to a destination other than the HSP50110 (a D/A, an NCO), the serial data can be output at a submultiple of the master clock. The master clock/slower clock selection is done here, and the speed of the slower clock slow clock is selected in menu item 14 of the carrier loop menu. If the tracking is done via the HSP50110, the master clock must be used.

### LOCK DETECTOR MENU

#### Item 1: Lock Detector Integration Time (Acquisition) [lkintgacq]

(1 to 1025)

This is the number of baud times that the magnitude of the carrier phase error is integrated before making decisions when searching for potential lock points during acquisition.

**Item 2: Lock Detector Integration Time (Tracking)**  
**[lkintgrk]**

(2 to 1025)

This is the number of baud times that the magnitude of the carrier phase error is integrated to when verifying a potential lock points and during tracking.

**Item 3: Lock Detector Acquisition Threshold [lkthracq]**

(In Degrees)

(0 to 180)

This is the average magnitude of the carrier phase error over the acquisition integration time. This is the decision threshold for potential lock points.

**Item 4: Lock Detector Tracking Threshold (In Degrees)**

**[lkthtrk]**

(0 to 180)

This is the average magnitude of the carrier phase error over the verification and tracking integration. This is the threshold used to switch back to acquisition mode.

**Item 5: Lock Verify Cycles (TRK Integration times)**

**[verifycnt]**

(0 to 15)

This is the number of lock detector integration periods that loop must be in lock before the state machine transitions from the verify to the lock state.

**Item 6: False Lock/Frequency Error Integ [flfesel]**

(0; 1)

0 = freq error; 1 = false lock

This item selects whether the false lock accumulator integrates the magnitude of the frequency error or the (square wave) false lock decisions when deciding whether a potential lock point is actually a false lock point.

**Item 7: False Lock Detector [flen]**

(0; 1)

0 = off; 1 = on

This item enables/disables false lock detection.

**Item 8: False Lock Threshold [flthr]**

(0 to Discriminator Range)

This sets the false lock threshold in % of symbols that indicate (square wave) false lock or Hz of freq error.

**Item 9: False Lock Sweep Count [flswpcnt]**

(0 to 15)

This is the number of lock detector integration times that sweep is forced to move beyond a false lock point.

---

All Intersil semiconductor products are manufactured, assembled and tested under **ISO9000** quality systems certification.

*Intersil semiconductor products are sold by description only. Intersil Corporation reserves the right to make changes in circuit design and/or specifications at any time without notice. Accordingly, the reader is cautioned to verify that data sheets are current before placing orders. Information furnished by Intersil is believed to be accurate and reliable. However, no responsibility is assumed by Intersil or its subsidiaries for its use; nor for any infringements of patents or other rights of third parties which may result from its use. No license is granted by implication or otherwise under any patent or patent rights of Intersil or its subsidiaries.*

For information regarding Intersil Corporation and its products, see web site <http://www.intersil.com>