

Radiation Hardened Quad Differential Line Driver

The Intersil HS-26C31RH is a quad differential line driver designed for digital data transmission over balanced lines and meets the requirements of EIA standard RS-422. Radiation hardened CMOS processing assures low power consumption, high speed, and reliable operation in the most severe radiation environments.

The HS-26C31RH accepts CMOS signal levels and converts them to RS-422 compatible outputs. This circuit uses special outputs that enable the drivers to power-down without loading down the bus. Enable and disable pins allow several devices to be connected to the same data source and addressed independently.

Specifications

Specifications for Rad Hard QML devices are controlled by the Defense Supply Center in Columbus (DSCC). The SMD numbers listed here must be used when ordering.

Detailed Electrical Specifications for these devices are contained in SMD 5962-96663. A “hot-link” is provided on our homepage for downloading.
www.intersil.com/military/

Features

- Electrically Screened to SMD # 5962-96663
- QML Qualified per MIL-PRF-38535 Requirements
- 1.2 Micron Radiation Hardened CMOS
 - Total Dose Up to 300kRAD(Si)
 - Dose Rate Upset > 1x10⁹ RAD/s (20ns Pulse)
- Latchup Free
- EIA RS-422 Compatible Outputs (Except for IOS)
- CMOS Inputs
- High Impedance Outputs when Disabled or Powered Down
- Low Power Dissipation 2.75mW Standby (Max)
- Single 5V Supply
- Low Output Impedance 10Ω or Less
- Full -55°C to +125°C Military Temperature Range

Applications

- Line Transmitter for MIL-STD-1553 Serial Data Bus

Ordering Information

ORDERING NUMBER	INTERNAL MKT. NUMBER	PART MARKING	TEMP. RANGE (°C)	PACKAGE	PKG. DWG. #
5962F9666301QEC	HS1-26C31RH-8	Q 5962F96 6630QEC	-55 to +125	16 LD SBDIP	D16.3
5962F9666301QXC	HS9-26C31RH-8	Q 5962F96 66301QXC	-55 to +125	16 LD FLATPACK	K16.A
5962F9666301VEC	HS1-26C31RH-Q	Q 5962F96 66301VEC	-55 to +125	16 LD SBDIP	D16.3
5962F9666301VXC	HS9-26C31RH-Q	Q 5962F96 66301VXC	-55 to +125	16 LD FLATPACK	K16.A
HS1-26C31RH/PROTO	HS1-26C31RH/PROTO	HS1- 26C31RH/PROTO	-55 to +125	16 LD SBDIP	D16.3
HS9-26C31RH/PROTO	HS9-26C31RH/PROTO	HS9- 26C31RH/PROTO	-55 to +125	16 LD FLATPACK	K16.A
5962F9666301V9A	HSO-26C31RH-Q		-55 to +125		

HS-26C31RH

Pinouts

HS9-26C31RH (16 LD FLATPACK) CDFP4-F16
TOP VIEW

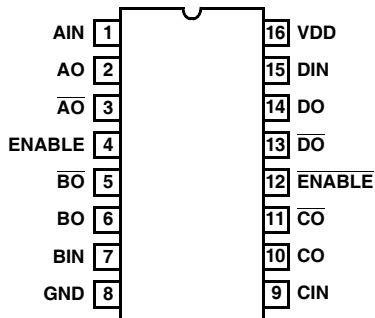

HS1-26C31RH (16 LD SBDIP) CDIP2-T16
TOP VIEW

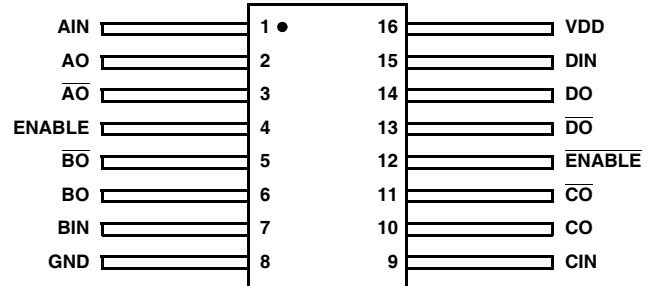

Logic Diagram

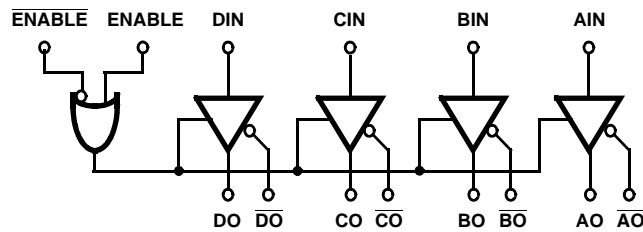

All Intersil U.S. products are manufactured, assembled and tested utilizing ISO9000 quality systems.
Intersil Corporation's quality certifications can be viewed at www.intersil.com/design/quality

Intersil products are sold by description only. Intersil Corporation reserves the right to make changes in circuit design, software and/or specifications at any time without notice. Accordingly, the reader is cautioned to verify that data sheets are current before placing orders. Information furnished by Intersil is believed to be accurate and reliable. However, no responsibility is assumed by Intersil or its subsidiaries for its use; nor for any infringements of patents or other rights of third parties which may result from its use. No license is granted by implication or otherwise under any patent or patent rights of Intersil or its subsidiaries.

For information regarding Intersil Corporation and its products, see www.intersil.com

Die Characteristics

DIE DIMENSIONS:

96.5 mils x 195 mils x 21 mils
(2450 x 4950)

INTERFACE MATERIALS:

Glassivation:

Type: PSG (Phosphorus Silicon Glass)
Thickness: 10kÅ ±1kÅ

Metallization:

M1: Mo/TiW
Thickness: 5800Å
M2: Al/Si/Cu (Top)
Thickness: 10kÅ ±1kÅ

Substrate:

AVLSI1RA

Backside Finish:

Silicon

ASSEMBLY RELATED INFORMATION:

Substrate Potential (Powered Up):

V_{DD}

ADDITIONAL INFORMATION:

Worst Case Current Density:

<2.0x10⁵A/cm²

Bond Pad Size:

110µm x 100µm

Metallization Mask Layout

