

## Description

The ISL97516IUZEVALZ evaluation board is an evaluation kit for evaluating the ISL97516IUZEVALZ, a step-up voltage regulator that operates with high frequency and high efficiency. This evaluation kit is designed to deliver over 90% efficiency.

The ISL97516IUZEVALZ kit provides a dip switch that allows users to select either 620kHz or 1.2MHz switching frequency.

## Key Features

- A Complete Evaluation Platform for the ISL97516 Evaluation
- Input Voltage: 2.3V to 5.5V
- Proven Evaluation Board Layout
- Pb-Free (RoHS Compliant)

## What is Needed

The following instruments will be needed to perform testing:

- Power supplies
- DC Electronic load
- Multimeters
- Oscilloscope
- Cables and wires

## Pinout

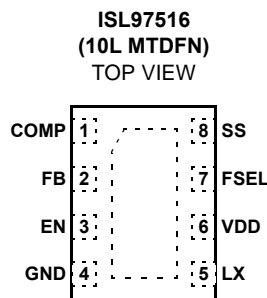

## Quick Setup Guide

1. Connect power supply between headers of  $V_{IN}$  and GND. The positive output of the power supply should be connected to  $V_{IN}$  header. Set power supply voltage between 2.3V and 5V, and current limit at 3A.
2. Connect E-load between headers of  $V_{OUT}$  and GND. The positive input of the E-load should be connected to  $V_{OUT}$  header. Set E-load current. The load current should not exceed the maximum output current the part can supply.
3. Close pins 1 and 4 of S1 to tie FSEL pin to VIN. This will set the switching frequency to 1.2MHz. Open pins 1 and 4 to pull FSEL to ground with  $R_4$  to set 620kHz.
4. Close pins 2 and 3 of S1 to tie EN pin to VIN to enable the part. To disable the part, open pins 2 and 3 to pull EN to ground with  $R_3$  to disable the part.

Make sure all the connections on the evaluation board are correct, then turn on power supply and E-load. The part starts to operate.

## Maximum Output Current

The MOSFET current limit is normally 2.0A and guaranteed 1.7A. This restricts the maximum output current that the ISL97516 can drive. Table 1 shows the ISL97516EVAL1Z maximum output current,  $I_{OMAX}$  in different input and output voltages.

TABLE 1. TYPICAL MAXIMUM  $I_{OUT}$  VALUES

$V_{IN}$ (V)	$V_{OUT}$ (V)	$I_{OMAX}$ (mA)
2.5	5	870
2.5	9	500
2.5	12	380
3.3	5	1150
3.3	9	655
3.3	12	500
5	9	990
5	12	750

## Ordering Information

PART NUMBER	DESCRIPTION
ISL97516IUZEVALZ	Evaluation Board for ISL97516

Board Design Schematic

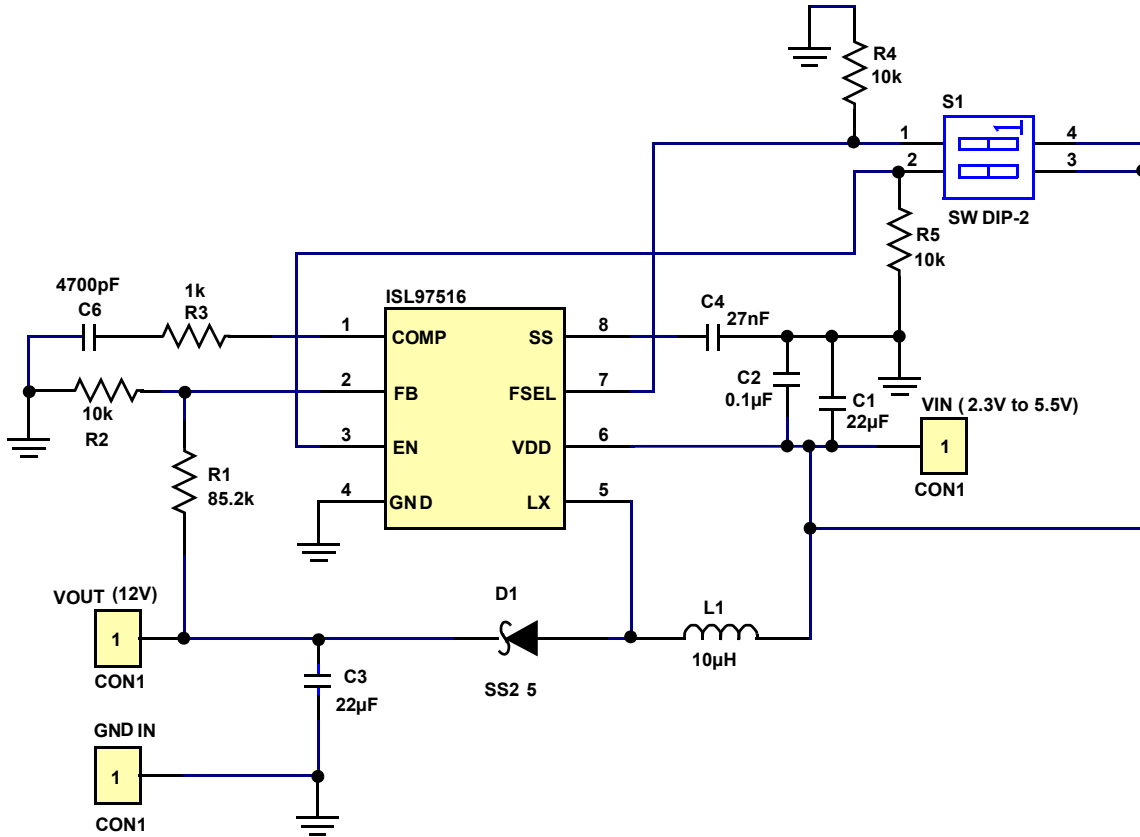

FIGURE 1. SCHEMATIC

TABLE 2. ISL97516IUZEVALZ BILL OF MATERIALS (BOM)

ITEM	QTY	REFERENCE	PART DESCRIPTION	PCB FOOTPRINT	PART NUMBER	VENDOR
1	1	C4	27nF	603		TDK
2	1	C6	4700pF	603		TDK
3	1	C2	0.1µF/16V	603	C1068X7R1H104K	TDK
4	1	R1	85.2k	603		WALSIN
5	3	R2, R4, R5	10k	603	WR06W1002JTL	WALSIN
6	1	R3	1k	603		
8	1	C3	22µF	1206		MURATA
9	1	C1	22µF	1206	GRM31CR61C226KE15L	MURATA
10	1	L1	10µH	CDRH8D43-100NC	GRM31CR61C226KE15L	SUMIDAc
11	1	U1	ISL97516	MSOP-8	CDRH8D43-100NC	INTERSIL
12	1	VOUT (12V)	CON1	Powerpost	ISL97516	
13	1	VIN (3.3V)	CON1	Powerpost		
14	1	GND IN	CON1	Powerpost		
15	1	D1	SS25	DO-214A	SS25	Fairchild
16	1	S1	SWDIP-2	DIP4		CKN3001-ND

PCB Layout

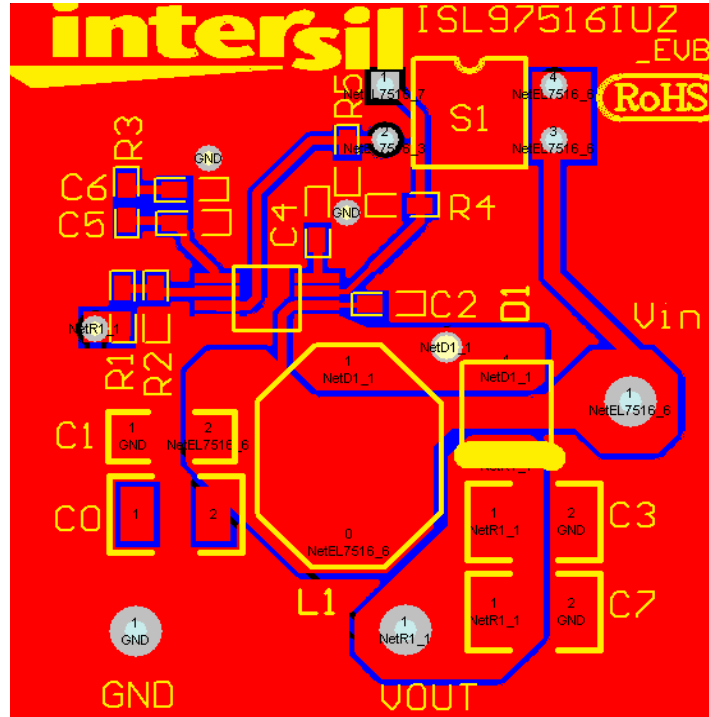

FIGURE 1. EVALUATION BOARD ASSEMBLY LAYER

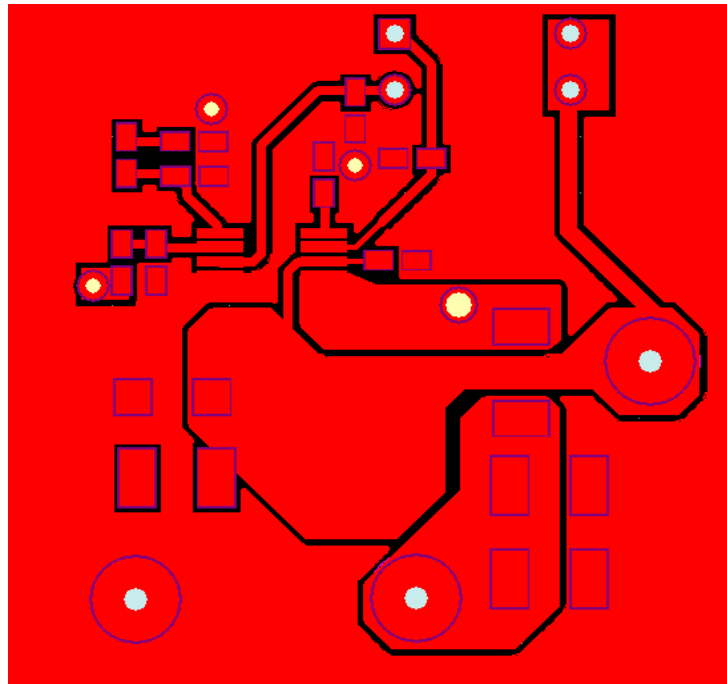

FIGURE 2. TOP LAYER

PCB Layout (Continued)

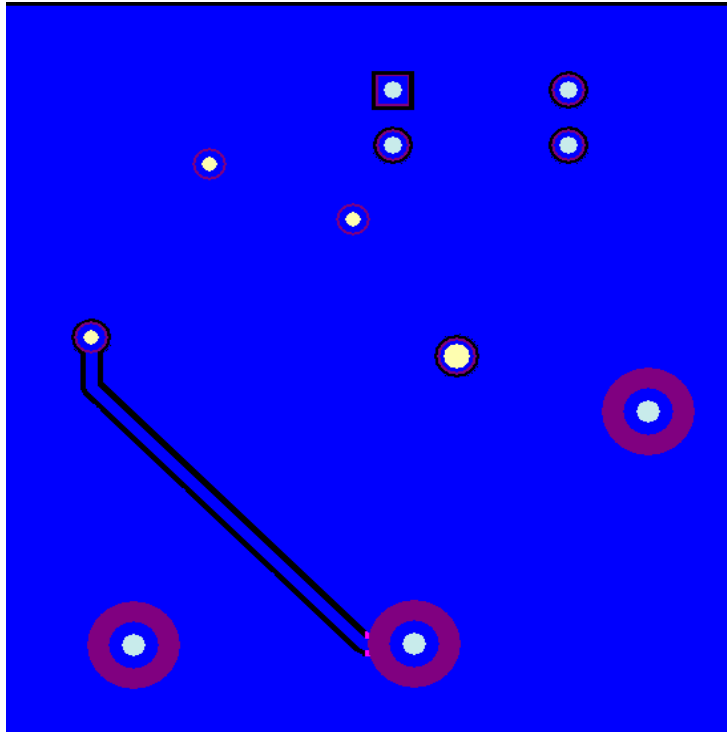

FIGURE 3. BOTTOM LAYER

Intersil Corporation reserves the right to make changes in circuit design, software and/or specifications at any time without notice. Accordingly, the reader is cautioned to verify that the Application Note or Technical Brief is current before proceeding.

For information regarding Intersil Corporation and its products, see [www.intersil.com](http://www.intersil.com)