

Description

The ISL8014EVAL2Z kit is intended for use by individuals with requirements for Point-of-Load applications sourcing from 2.7V to 5.5V. The ISL8014EVAL2Z evaluation board demonstrates the performance of the ISL8014 low quiescent current mode converter.

The ISL8014 is offered in a 4mmx4mm 16 Ld QFN package with 1mm maximum height. The ISL8014 is pin-to-pin compatible to the ISL8013. The complete converter occupies less than 0.4in² area.

Key Features

- High Efficiency Synchronous Buck Regulator with up to 95% Efficiency
- Power-Good (PG) Output with 1ms Delay
- 2.7V to 5.5V Supply Voltage
- 3% Output Accuracy Over-Temperature/Load/Line
- 4A Guaranteed Output Current
- Start-up with Pre-biased Output
- Internal Digital Soft-Start - 1ms
- Soft-Stop Output Discharge During Disabled
- 35µA Quiescent Supply Current in PFM Mode
- Selectable Forced PWM Mode and PFM Mode
- External Synchronization up to 4MHz
- Less than 1µA Logic Controlled Shutdown Current
- 100% Maximum Duty Cycle for Lowest Dropout
- Internal Current Mode Compensation
- Peak Current Limiting and Hiccup Mode Short Circuit Protection
- Over-Temperature Protection

Recommended Equipment

The following materials are recommended to perform testing:

- 0V to 10V Power Supply with at least 5A Source Current Capability or 5V Battery
- Electronic Loads Capable of Sinking Current Up to 5A
- Digital Multimeters (DMMs)
- 100MHz Quad-trace Oscilloscope
- Signal Generator

Quick Setup Guide

1. Ensure that the circuit is correctly connected to the supply and loads prior to applying any power.
2. Connect the bias supply to VIN. Plus terminal to P4 (VIN) and negative return to P5 (GND).
3. Verify that position is ON for SW1.
4. Turn on the power supply.
5. Verify the output voltage is 1.8V for V_{OUT}

Evaluating the Other Output Voltage

The ISL8014EVAL2Z kit output is preset to 1.8V; however, output voltages can be adjusted from 0.8V to 3.3V using Equations 1 and 2:

$$V_{OUT} = 0.8 \left(1 + \frac{R_1}{R_2} \right) \quad (\text{EQ. 1})$$

Let's set R₁ = 124kΩ

$$R_2 = \frac{(R_1)}{\left(\frac{V_{OUT}}{0.8} \right) - 1} \quad (\text{EQ. 2})$$

Note: If desired output is 0.8V, then short R₁ and open R₂.

Mode Control

The ISL8014 has a SKIP pin that controls the operation mode. When the SKIP pin is driven to low or shorted to ground, the regulator operates in a PFM mode. Set SKIP pin high forced PWM mode. The controller remains in the fixed PWM frequency at light load instead of entering the skip mode. In an application where situations require the ISL8014 regulator to sink more than 2A valley inductor current, it is recommended to operate in PFM to avoid any possible over stress.

TABLE 1. SWITCH 1 SETTINGS

SW1	ENABLE	ON/OFF CONTROL
1	OFF	Disable V _{OUT}
3	ON	Enable V _{OUT}
SW2	SKIP	FUNCTION
1	PWM	Fixed PWM frequency at light load
3	PFM	Force continuous mode

ISL8014EVAL2Z Schematic

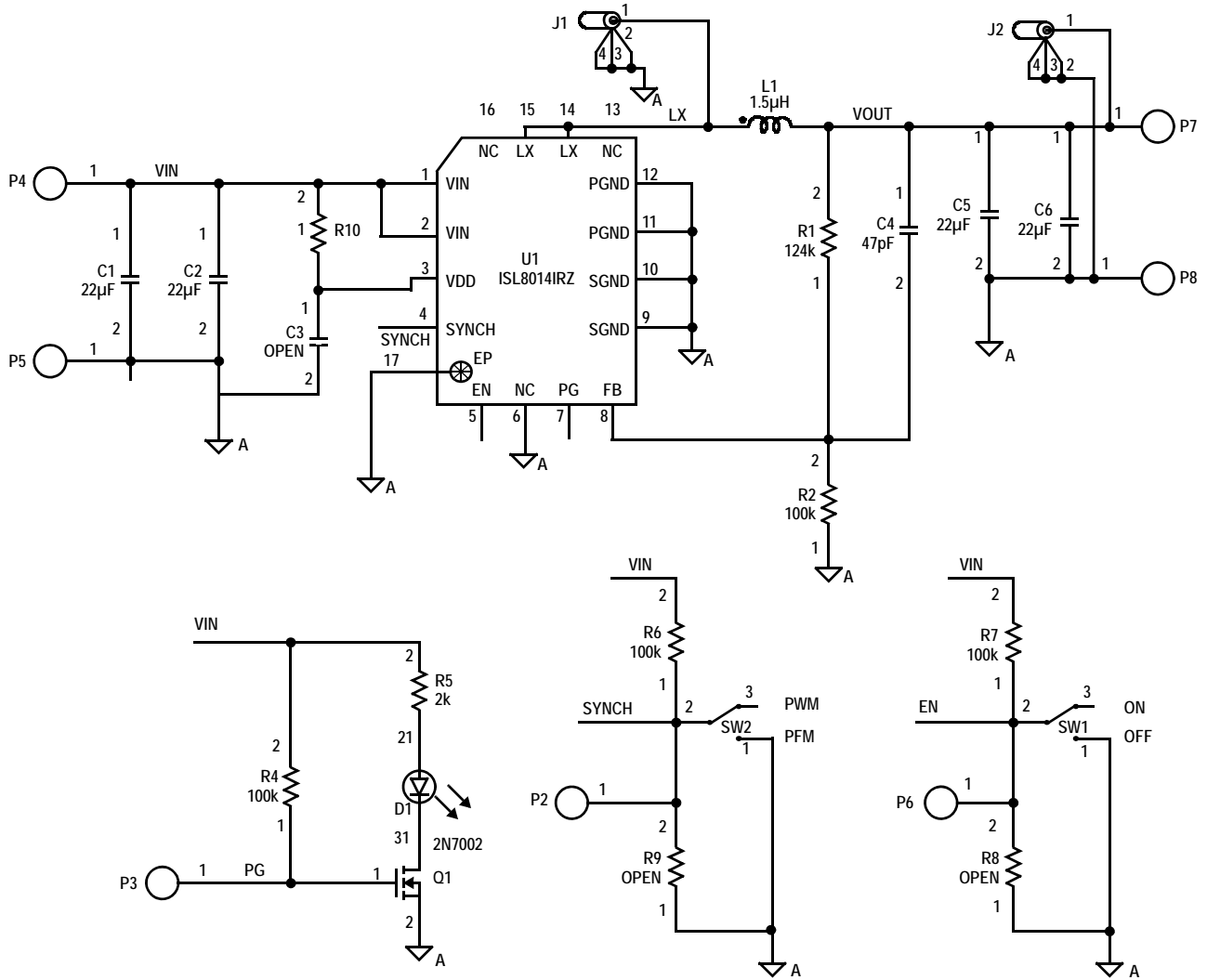

NOTE: Pins 13 and 16 are no connect pins which can tie to VIN, SGND, or LX. Recommend connecting pin 13 to LX for compatibility to ISL8013.

Application Note 1366

ISL8014EVAL2Z Bill of Materials

PART NUMBER	QTY	REFERENCE DESIGNATOR	DESCRIPTION	MANUFACTURER	MANUFACTURER PART
ISL8014EVAL2Z	1		PWB-PCB, ISL8014EVAL2Z, REVA, ROHS		ISL8014EVAL2ZREVAPCB
H1045-00470-50V5-T	1	C4	CAP, SMD, 0603, 47pF, 50V, 5%, NPO, ROHS	AVX	06035A470JAT2A
				PHILLIPS	0603X7R500-562KNE
H1045-DNP	0	C3	CAP, SMD, 0603, DNP-PLACE HOLDER, ROHS		
H1065-00226-6R3V10-T	4	C1, C2, C5, C6	CAP, SMD, 1206, 22µF, 6.3V, 10%, X5R, ROHS	MURATA	GRM31CR60J226KE19L
				KEMET	C1206C226K9PACTU
				AVX	12066D226KAT2A
DR73-1R5-R	1	L1	COIL-PWR INDUCTOR, SMD, 7.5mm, 1.5µH, 20%, 6.52A, ROHS	COOPER ELECTRONIC TECH.	DR73-1R5-R
131-4353-00	2	J1, J2	CONN-SCOPE PROBE TEST PT, COMPACT, PCB MNT, ROHS	TEKTRONIX	131-4353-00
1514-2	4	P4, P5, P7, P8	CONN-TURRET, TERMINAL POST, TH, ROHS	KEYSTONE	1514-2
5002	3	P2, P3, P6	CONN-MINI TEST POINT, VERTICAL, WHITE, ROHS	KEYSTONE	5002
LTST-C170CKT	1	D1	LED-GaAs RED, SMD, 2mmx1.25mm, 100mW, 40mA, 10mcd, ROHS	LITEON/VISHAY	LTST-C170CKT
				ROHM	SML-210LTT86
				STANLEY ELECTRIC	BR112H-TR
ISL8014IRZ	1	U1	IC-4A, 1MHz, BUCK REGULATOR, 16P, QFN, 4x4, ROHS	INTERSIL	ISL8014IRZ
2N7002-7-F-T	1	Q1	TRANSISTOR, N-CHANNEL, 3LD, SOT-23, 60V, 115mA, ROHS	DIODES, INC.	2N7002-7-F
				ON SEMICONDUCTOR	2N7002LT1G
H2511-00R00-1/10W-T	1	R10	RESISTOR, SMD, 0603, 0Ω, 1/10W, TF, ROHS		
H2511-01003-1/10W1-T	4	R2, R4, R6, R7	RES, SMD, 0603, 100k, 1/10W, 1%, TF, ROHS		
H2511-01243-1/10W1-T	1	R1	RES, SMD, 0603, 124k, 1/10W, 1%, TF, ROHS	YAGEO	9C06031A1243FKHFT
				PANASONIC	ERJ-3EK1243V
H2511-02001-1/10W1-T	1	R5	RES, SMD, 0603, 2k, 1/10W, 1%, TF, ROHS	KOA	RK73H1JTTD2001F
				VENKEL	CR0603-10W-2001FT
H2511-DNP	0	R8, R9	RES, SMD, 0603, DNP-PLACE HOLDER, ROHS		
GT11MSCBE-T	2	SW1, SW2	SWITCH-TOGGLE, SMD, ULTRAMINI, 1P, SPST MINI	C&K COMPONENTS	GT11MSCKE
LABEL-SERIAL NUMBER	1		LABEL, FOR SERIAL NUMBER AND BOM REV #		

ISL8014EVAL2Z Board Layout

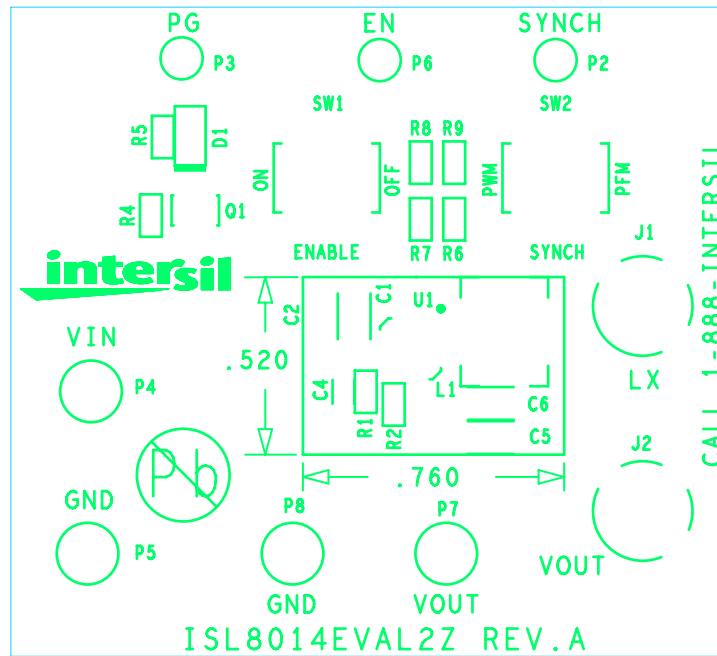

FIGURE 1. TOP COMPONENTS

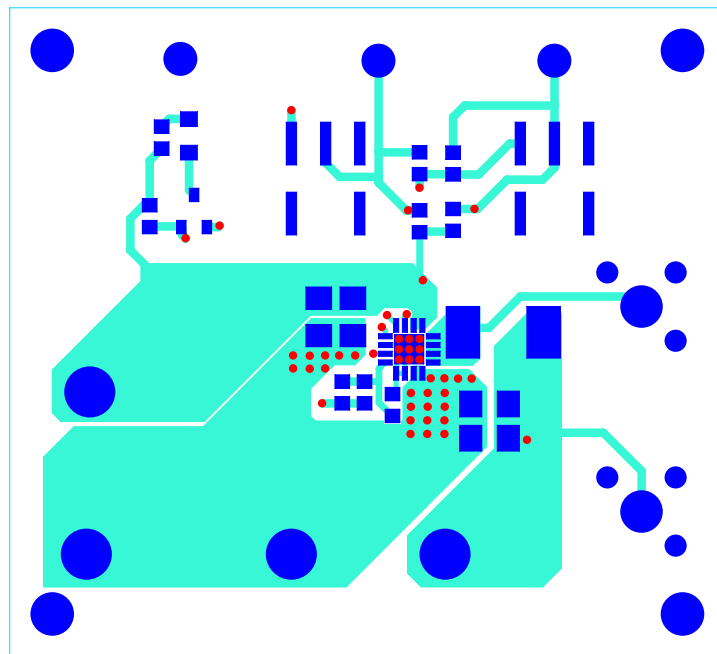

FIGURE 2. TOP LAYER ETCH

ISL8014EVAL2Z Board Layout (Continued)

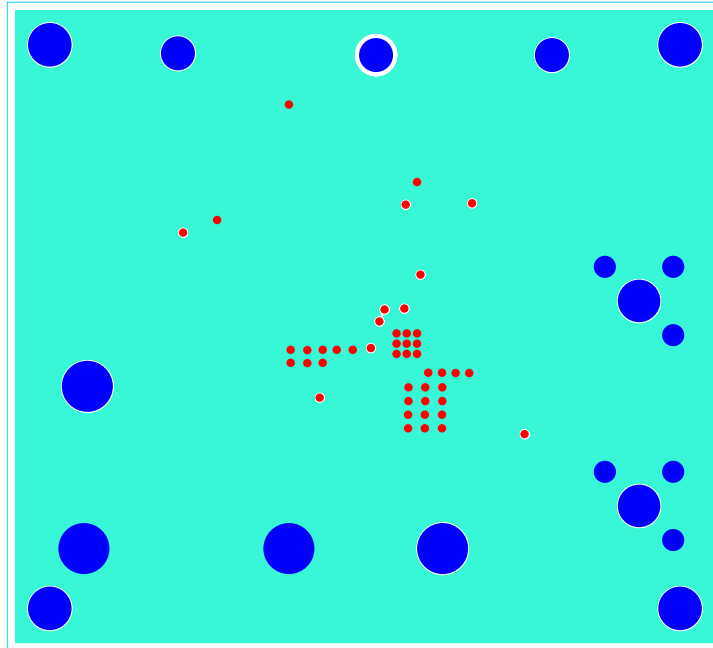

FIGURE 3. 2ND LAYER ETCH

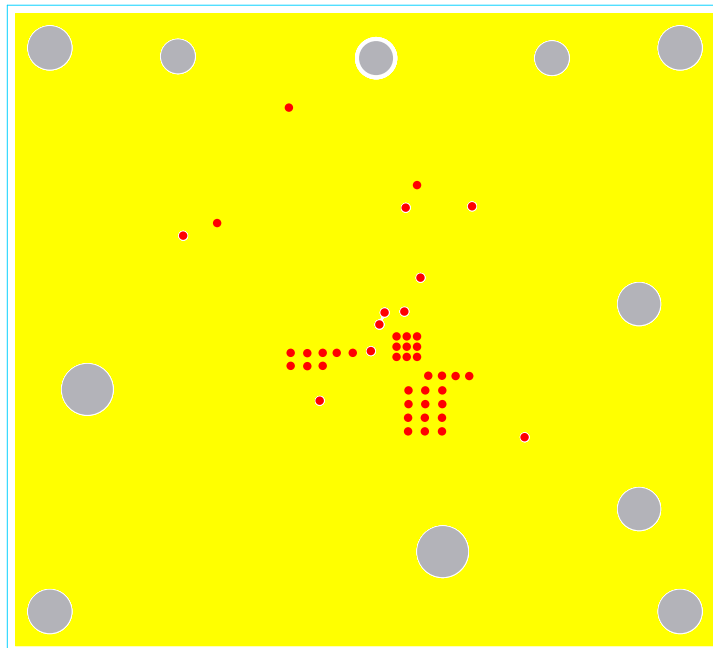

FIGURE 4. 3RD LAYER ETCH

ISL8014EVAL2Z Board Layout (Continued)

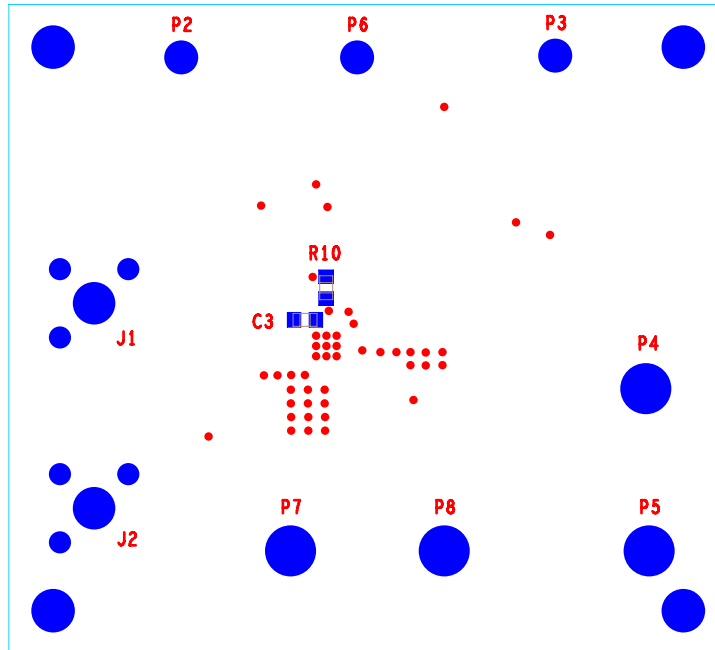

FIGURE 5. BOTTOM LAYER COMPONENTS (MIRRORS)

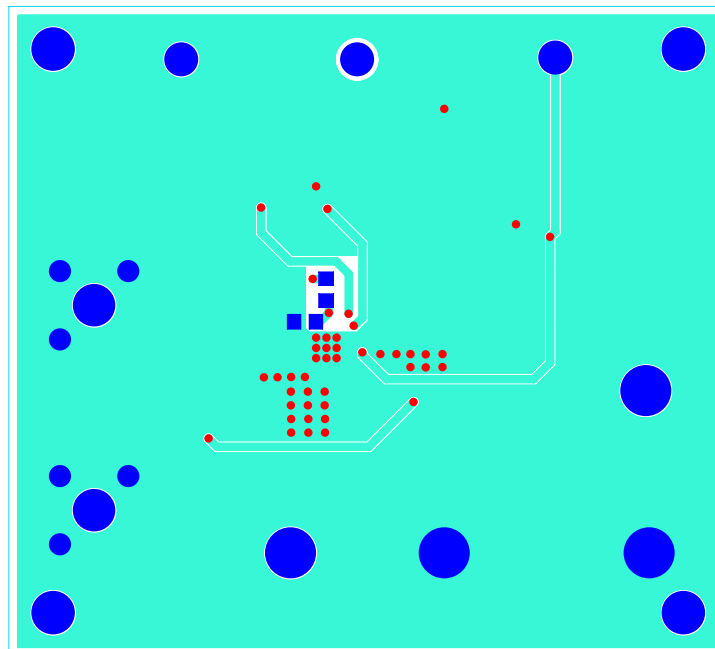

FIGURE 6. BOTTOM LAYER ETCH (MIRROR)

Intersil Corporation reserves the right to make changes in circuit design, software and/or specifications at any time without notice. Accordingly, the reader is cautioned to verify that the Application Note or Technical Brief is current before proceeding.

For information regarding Intersil Corporation and its products, see www.intersil.com