

Introduction

The ISL2819xEVAL1Z evaluation board is a design platform containing all the circuitry needed to characterize critical performance parameters of the ISL28190 and ISL28191 single operational amplifiers, using a variety of user defined test circuits.

The ISL28190 and ISL28191 amplifiers feature ultra-low noise, ultra-low distortion, and rail-to-rail output drive capability. They are designed to operate with single and dual supplies from +5.5VDC (± 2.75 VDC) down to +3VDC (± 1.5 VDC).

Reference Documents

- ISL28190 Data Sheet, FN6247
- ISL28191 Data Sheet, FN6156

Evaluation Board Key Features

The ISL2819xEVAL1Z is designed to enable the IC to operate from a single supply (+3VDC to +5.5VDC), or from split supplies (± 1.5 VDC to ± 2.75 V). The board is configured for a single op amps connected for differential input with a closed loop gain of 10. A single external reference voltage (VREF) pin and provisions for a user-selectable voltage divider (filter is included).

Power Supplies (Figure 1)

External power connections are made through the V+, V-, and Ground connections on the evaluation board. For single supply operation, the V- and Ground pins are tied together to the power supply negative terminal. For split supplies V+ and V- terminals connect to their respective power supply terminals. De-coupling capacitors C₁ and C₂ connect to ground through R₁ and R₂₁ 0 Ω resistors. Resistors R₂₀ and

R₂₄ are 0 Ω but can be changed by the user to provide additional power supply filtering, or to reduce the voltage rate-of-rise to less than ± 1 V/ μ s. Two additional capacitors, C₃ and C₄ are connected close to the part to filter out high frequency noise. Anti-reverse diodes D₁ and D₂ protect the circuit in the case of accidental polarity reversal.

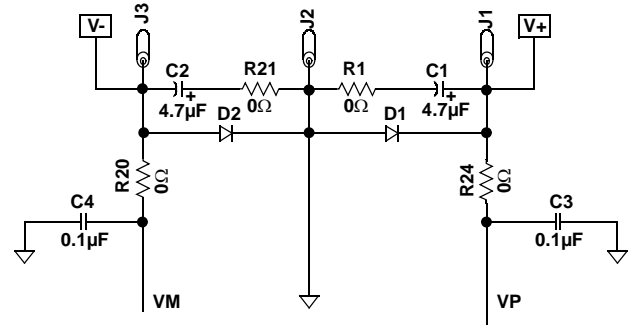

FIGURE 1. POWER SUPPLY CIRCUIT

Amplifier Configuration (Figure 2)

The schematic of the op amp with the components supplied is shown in Figure 2. The circuit implements a differential input amp with a closed loop gain of 10. The circuit can operate from a single 3VDC to +5.5VDC supply, or from dual supplies from ± 1.5 VDC to ± 2.75 VDC. The VREF pin can be connected to ground to establish a ground referenced input for split supply operation, or can be externally set to any reference level for single supply operation.

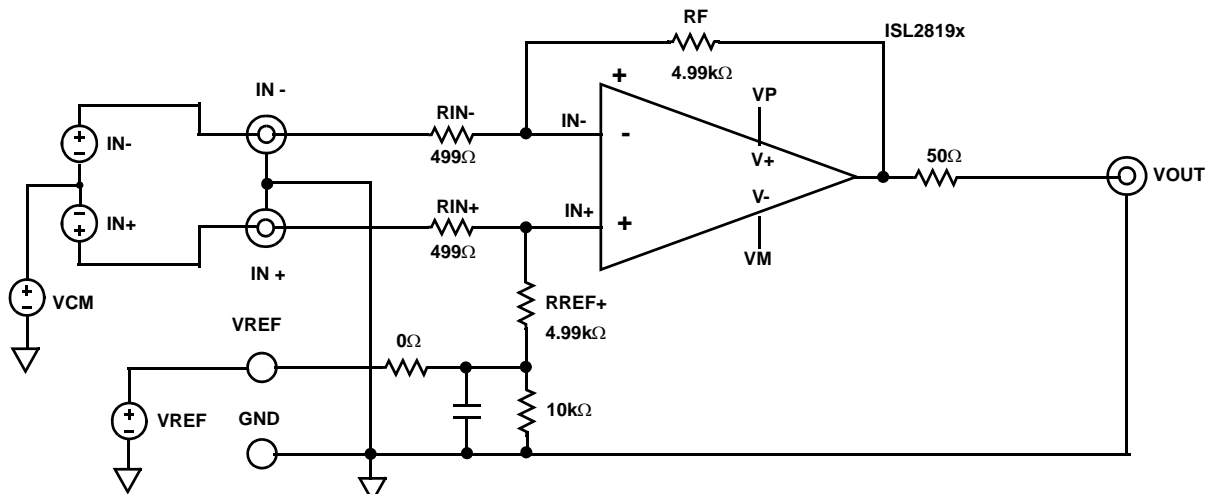

FIGURE 2. BASIC AMPLIFIER CONFIGURATION

User-Selectable Options (Figures 3 and 4)

Component pads are included to enable a variety of user-selectable circuits to be added to the amplifier inputs, the VREF input, outputs and the amplifier feedback loops.

A voltage divider and filter option (Figure 3) can be added to establish a power supply-tracking common mode reference at the VREF input. The inverting and non-inverting inputs

have additional resistor placements for adding input attenuation, or to establish input DC offsets through the VREF pin.

The output (Figure 4) has a series 50Ω back-termination resistor to drive 50Ω cables, and additional resistor and capacitor placements for loading.

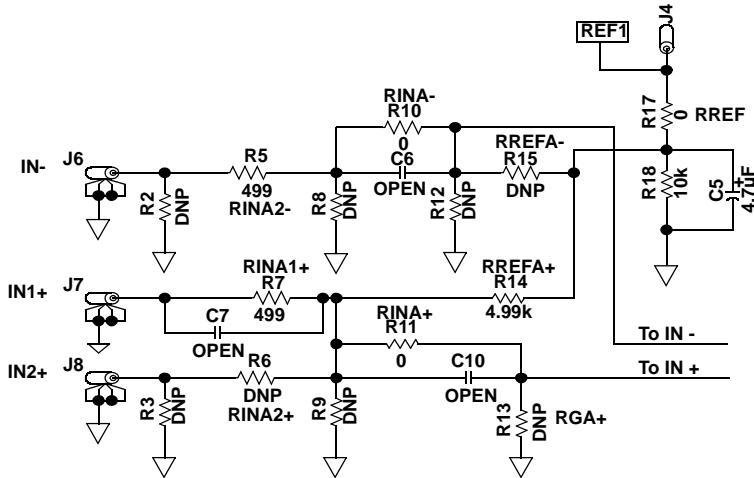

FIGURE 3. INPUT STAGE

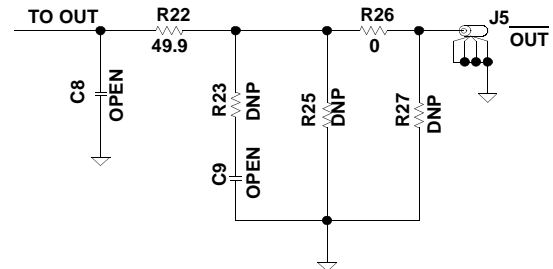
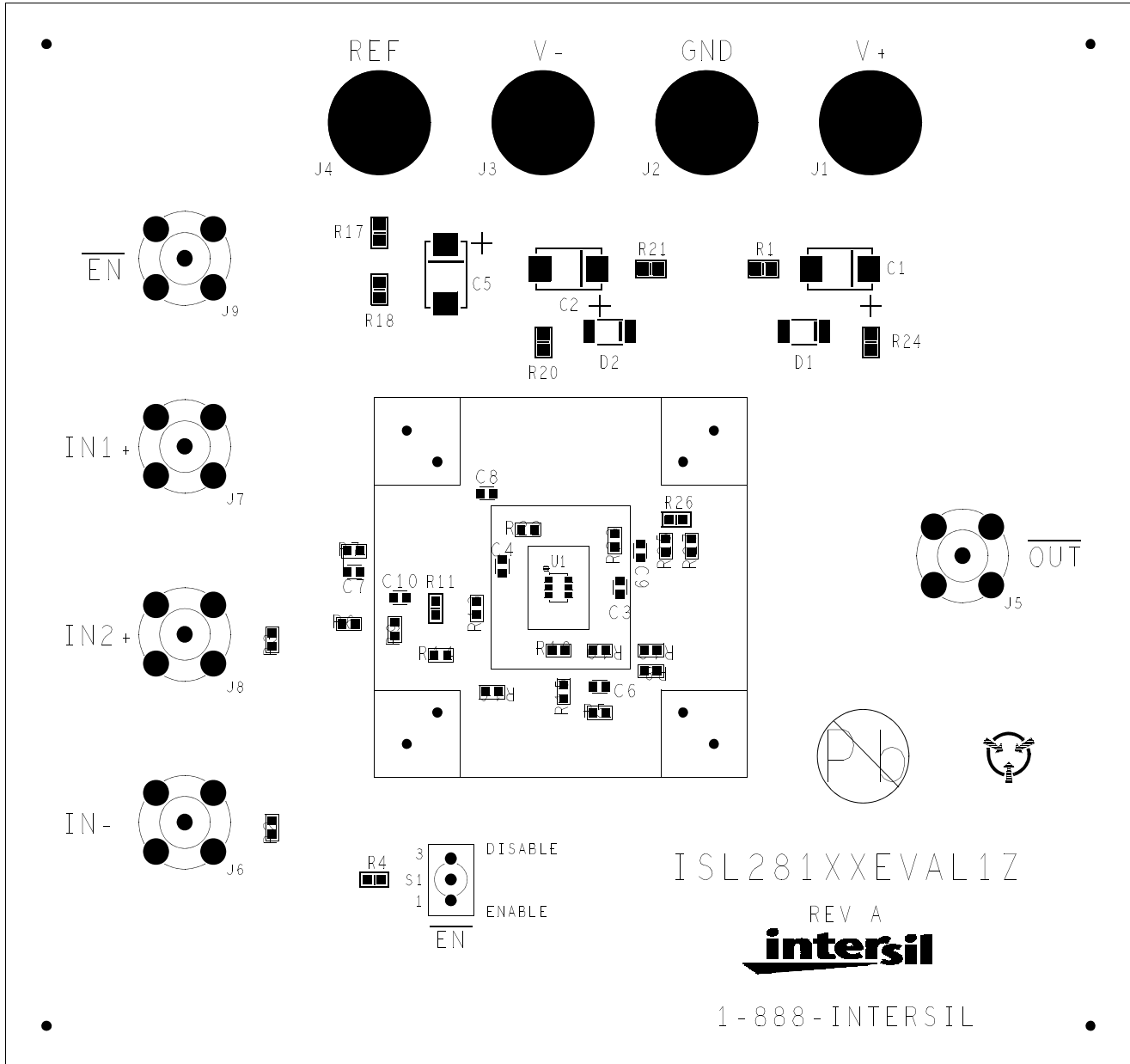

FIGURE 4. OUTPUT STAGE

ISL2819xEVAL1Z Components Parts List

DEVICE NUMBER	DESCRIPTION	COMMENTS
C1, C2, C5	CAP-TANTALUM, SMD, D, 4.7μF, 50V, 10%, LOW ESR, ROHS	Power supply decoupling
C3, C4	CAP, SMD, 0603, 0.1μF, 25V, 10%, X7R, ROHS	Power supply decoupling
C6-C10	CAP, SMD, 0603, DNP-PLACE HOLDER, ROHS	User selectable capacitors - not populated
D1, D2	DIODE-RECTIFIER, SMD, SOD-123, 2P, 40V, 0.5A, ROHS	Reverse power protection
U1 (ISL28190EVAL1Z)	ISL28190FHZ-T7, IC-RAIL-TO-RAIL OP AMP, SOT-23, ROHS	
U1 (ISL28191EVAL1Z)	ISL28191FHZ-T7, IC-RAIL-TO-RAIL OP AMP, SOT-23, ROHS	
R2, R3, R6, R8, R9, R12, R13, R15, R16, R23, R25, R27	RESISTOR, SMD, 0603, 0.1%, MF, DNP-PLACE HOLDER	User selectable resistors - not populated
R1, R10, R11, R17, R20, R21, R24, R26	RES, SMD, 0603, 0Ω, 1/10W, TF, ROHS	0Ω user selectable resistors
R22	RES, SMD, 0603, 49.9Ω, 1/10W, 1%, TF, ROHS	User selectable output resistors
R5, R7	RES, SMD, 0603, 499Ω, 1/10W, 1%, TF, ROHS	Gain resistors
R14, R19	RES, SMD, 0603, 4.99k, 1/10W, 1%, TF, ROHS	Gain resistors
R4, R18	RES, SMD, 0603, 10k, 1/10W, 1%, TF, ROHS	User selectable resistors

ISL2819xEVAL1Z Top View



ISL2819xEVAL1Z Schematic Diagram

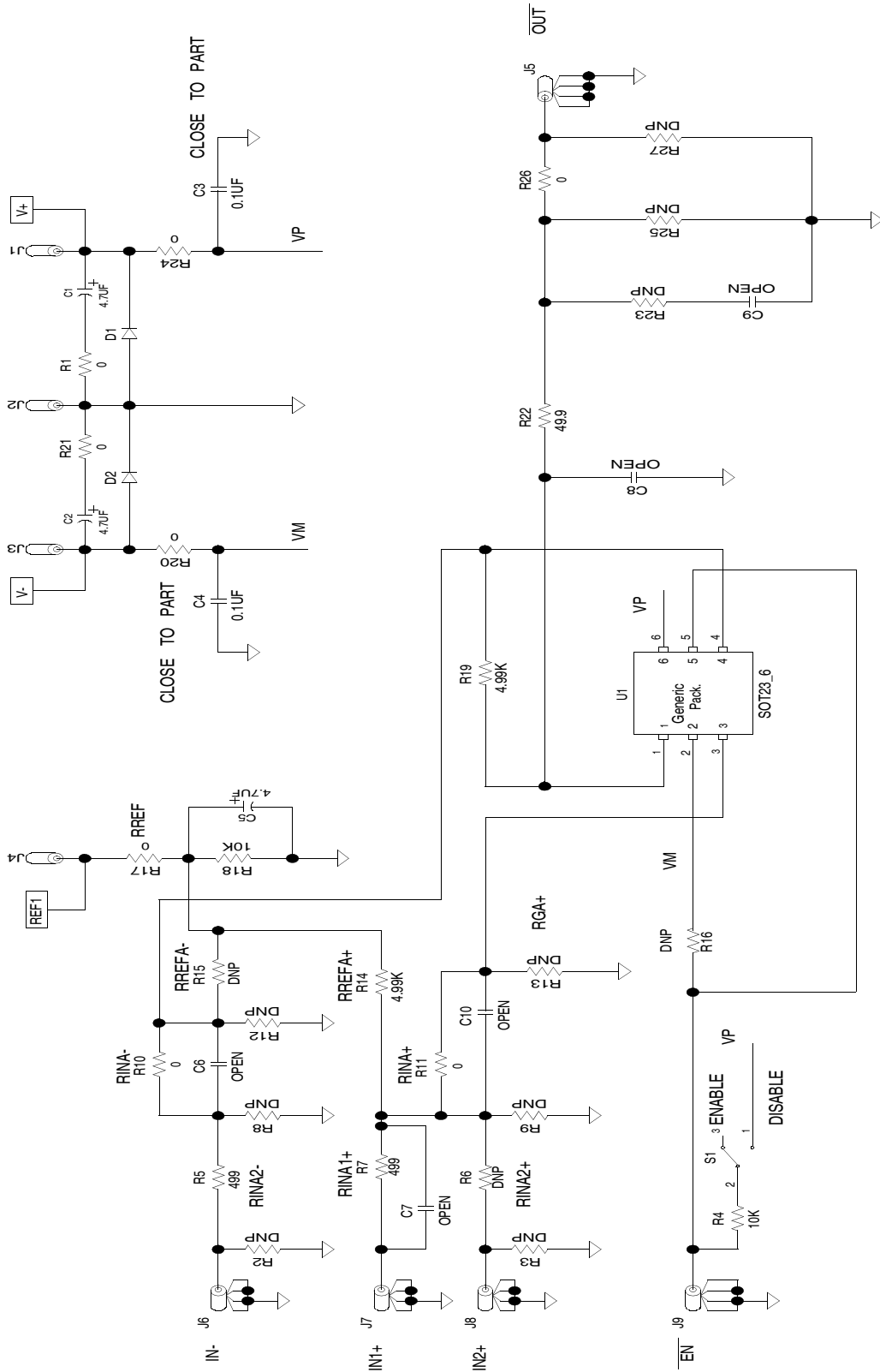

Intersil Corporation reserves the right to make changes in circuit design, software and/or specifications at any time without notice. Accordingly, the reader is cautioned to verify that the Application Note or Technical Brief is current before proceeding.

For information regarding Intersil Corporation and its products, see www.intersil.com