

Description

The ISL6295EVAL1 is an evaluation tool for the ISL6295 low voltage fuel gauge IC. The evaluation tool provides a complete evaluation platform addressing all datasheet specifications and functionalities. The complete evaluation kit includes the ISL6295EVAL1 evaluation board, the DeVaSys USB-I²C interface board, the interconnection cables, the PC base host software CD and manual.

The ISL6295EVAL1 evaluation board incorporates a typical Li-Ion battery pack protection circuit including a safety IC and a dual MOSFET. The circuit also includes a precision sense resistor for the charge and discharge current measurements. An industry standard 10kΩ at +25°C negative temperature coefficient (NTC) device (Semitec 103AT type) is provided for external temperature measurement. Friction-lock headers (Molex KK, 0.1" pin spacing) are provided for a easy connection on bench. Test points for all pins of the ISL6295 fuel gauge IC are provided with insert tips for convenient scope probing.

The ISL6295 is a highly integrated fuel gauge solution for single-cell Li-ion batteries. The IC communicates to the host via the industry standard I²C/SMBus port. While the evaluation software is designed for use with a MS Windows PC platform, it can easily be ported to run on other hardware and OS platforms such as Windows CE or Linux.

Ordering Information

PART #	DESCRIPTION
ISL6295EVAL1	Complete Evaluation Kit for ISL6295

IC Pinout

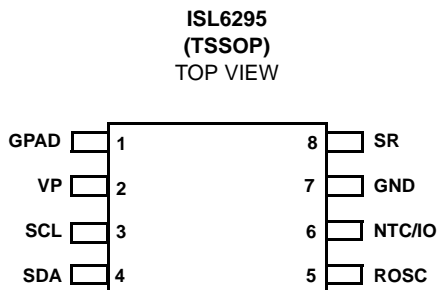

Features

- A Complete Evaluation Platform for the ISL6295 Fuel Gauge IC
- Easy to Use GUI Based Software Demonstrates Capabilities of the ISL6295 Device
- On-Board Precision Current Sense Resistor
- Flexible Power Connectors for Source and Load Connections
- Convenient Test Points for Easy Scope Measurements
- 2.5x1.75 Square Inches Board Size Handy for Evaluation
- USB Interface to the Host PC via the I²C to USB adapter Module
- Includes a Protection Circuit which fully Complies with the Li-Ion Battery Safety Requirements
- Fully Calibrated for the Best Accuracy

What is Included

The following items are included in the ISL6295EVAL1:

- ISL6295EVAL1 Evaluation Module
- DeVaSys USB-I²C Interface Card
- USB Cable
- Semitec 103AT Type Thermistor
- I²C Wire Harness
- Host Driver Installer CDRom
- Application Manual

What Else is Needed

The following instruments will be needed to set up and perform the evaluation:

- PC
 - Pentium II or higher
 - Windows 98, Windows 2000 or NT, Windows XP operation system
 - Minimum 128MB RAM
 - Minimum 1GB hard disk
 - USB port
- A DC power Supply with Adjustable Voltage up to 5V and 2A Current Capability, or a Single Cell Li-Ion Battery
- DC Electronic Load: 20V/2A
- Multimeters
- Oscilloscope
- Cables and Wires

Software Setup - BatteryBench 2.2

- Step 1: Insert the installation CD in the host PC.
- Step 2: If you have disabled the CD Autoplay feature, you can run the setup program manually by selecting the Start menu, choosing Run and typing D:\setup.exe (replace D with whatever is appropriate for your CD-ROM drive).
- Step 3: Follow the on-screen instructions to complete the installation.

Software Setup - DeVaSys USB-I²C/IO Driver

- Step 1: Plug the USB-I²C/IO board into your computer, using the provided USB cable.
- Step 2: Your computer should detect the new hardware and prompt you for the location of the device driver.
- Step 3: Direct the installation dialogs to look in the CDROM for the device driver.
- Step 4: The new hardware wizard should complete and both the RED and GREEN LEDs on the USB-I²C/IO board should light.

Hardware Setup

- Step 1: Connect a fully charged single cell Li-Ion battery or a DC power supply with output set at 4V to the ISL6295EVAL1 connector J3.
- Step 2: Connect the I²C wire harness (provided) between J4 of the I²C Interface card and J2 of the ISL6295EVAL1 as shown in Figure 1.
- Step 3: Launch BatteryBench 2.2. Make sure the "Device Serial ID" window at the top of the page shows the ID number of the interface card. Follow the Voltage Measurement procedure in next section to check the pack voltage A/D result. If the result matches the reading of the voltmeter V1, the setup is correct.
- Step 4: Install a jumper shunt on JP1, then remove before proceeding. This step will allow the protection IC MM3077 to exit its power down mode, and is necessary to enable the discharge current path.
- Step 5: Connect the ammeter IL and the E-load between B+ and B- pins of J1 as shown in Figure 1. Set the E-load to sink 1.0A current. Follow the Current Measurement procedure in next section to check the current A/D result. The result should be a negative number, indicating a discharge current.

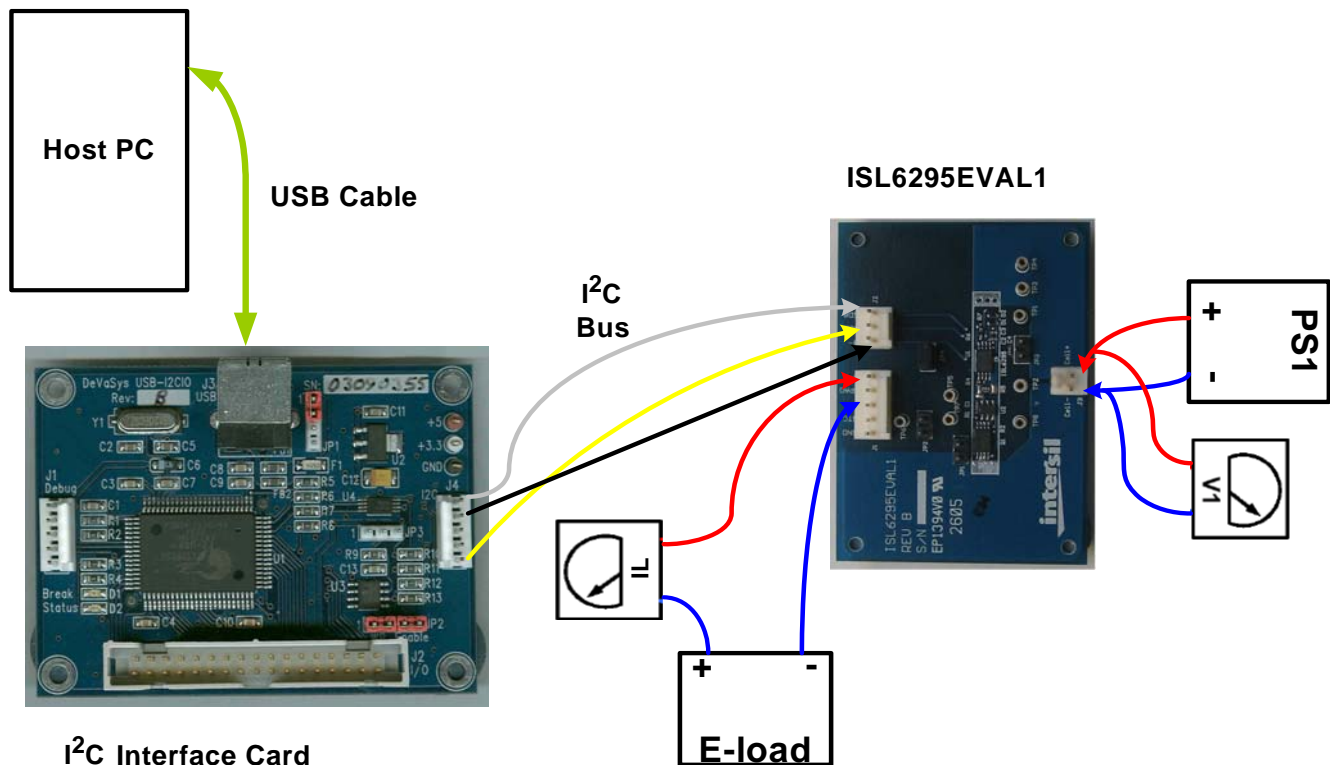

FIGURE 1. CONNECTION OF INSTRUMENTS

Evaluation Procedures

The following section describes the configuration and operation of the eval kit. Follow the “Software Setup” section to install the BatteryBench software in your PC. Follow the “Hardware Setup” section to connect the ISL6295EVAL1 evaluation kit.

Hardware Configuration

There are 4 jumper headers on the ISL6295EVAL1 evaluation board. The jumper settings are described as follows:

JP1 - Insert a jumper shunt on JP1 to bypass the protection FETs in case the evaluation is done with a DC source instead of a battery and you would like to evaluate beyond the 4.3V OVP limit. Note for safety reason the protection FETs must not be bypassed if a battery is used for the evaluation. Severe injury may result if the battery is over charged.

JP2 - Insert a jumper shunt on JP2 to connect the NTC pin to ground if not used.

JP3 - Insert a jumper shunt on JP3 to connect the GPAD pin to ground if not used.

JP4 - JP4 provides connection of an ammeter for the current flowing in or out of the B+ terminal. Insert a jumper shunt on JP4 if an ammeter is not connected.

There are 8 on-board test pins, TP1 to TP8, correspond to the IC pin numbers of the ISL6295 for convenient probing.

Connector J1 is for the pack connections including B+, B-, NTC, GPAD and GND. Connector J2 is for the I²C communication (wire harness provided). Connector J3 is for the cell connection. Each pin of the connectors are clearly marked on the board, please use precaution when making the connections.

Use 22 AWG wire, as short as possible for connection from J3 to the cell to minimize the IR drop on the wire, which may cause significant error for the battery voltage measurement. Also use 22 AWG wire for connection from B+ and B- to the load.

The electrical specifications of the parameters most relevant to the evaluation kit is provided in Table 1. Refer to the ISL6295 datasheet for the complete specifications of the fuel gauge IC.

TABLE 1. ELECTRICAL SPECIFICATIONS

PARAMETERS	OPERATING RANGE	UNITS
Charge/Discharge Current	2.5	A
(VB+) - (VB-)	2.8 to 4.3	V
	2.8 to 7.0 (Jumper shunt on JP1)	V
(Vcell+) - (Vcell-)	2.8 to 4.3	V
	2.8 to 7.0 (Jumper shunt on JP1)	V
GPAD Voltage	0 to 6.2	V
NTC Resistor Value	0 to 22	kΩ
Ambient temp	-20 to +85	°C

Software Configuration

After the BatteryBench 2.2 program is launched, the default tab is the A/D Controls/Results Registers. There are five tabs in the main program window. Each of these functional pages can be entered by left clicking the appropriate tab. Detailed description of each functional page will be provided in the following sections.

A/D Controls/Results Registers Tab

The A/D Controls/results Registers tab allows the user to configure the A/D converter, read the latest real-time measurement of charge/discharge current, pack voltage and temperature. The evaluation procedure is as follows:

1. Click the “Load Default Configs” button to load the default settings into the ISL6295 A/D control registers.
2. The default settings are 15-bit resolution. All input sources except the external temperature sensor are enabled. Make changes if necessary before proceeding. Click the “Update” and “Read” buttons for the changes to take effect.
3. The default data format is Calculated and Compensated in decimal numbers. This means the raw data has been processed to convert to real-life units, i.e. mA for current, mV for voltage, etc. The “Compensated” check box indicates that the calibration factors are included in the calculations. If you would like to display the raw data, which is the number of LSB counts from the A/D, check the “Raw” radio button in the “Display Settings” area.
4. To view the results continuously, check the “Loop” box at the bottom of the page and click the “Reading A/D Values” button. The results will be refreshed at a rated specified by the “Sample Div.” window on the “System Configuration” area.

The upper portion of this page provides System Configuration evaluation. The system control includes the General Purpose Input/Output (GPIO) and the Operation Mode Control (OPmode) evaluation. The “Sample Div.” drop down box allows the user to change the A/D conversion interval if the sample mode is selected by checking the “SAMP” box.

Current Measurement

The evaluation board includes the Li-Ion protection circuit implemented with a protection IC and a dual MOSFET. Since the OVP threshold of the protection IC is set at 4.3V, when a power supply is used, the voltage must be below the OVP threshold to turn on the charge MOSFET. An electronic load or a power resistor is used to force a current through the sense resistor. The full scale dynamic range at the SR pin is $\pm 152\text{mV}$, thus the maximum measurable current is 7.6A if permitted by thermal constraints.

To request the charge and discharge current measurements, the A/D control register Ictrl must be enabled by checking

the enable box for "Current". Specify the A/D conversion resolution, click "Update" and then "Read." The current value will be displayed on the "Results" area. A negative value indicates a discharge current while a positive value indicates a charge current condition.

Since 170mV is used as the reference voltage, if 15-bit resolution is selected for the A/D convention, the LSB in units of current is:

$$\text{Current LSB} = \frac{170\text{mV}}{2^{15} \times 20\text{m}\Omega} = 259.5\mu\text{A}$$

System Configuration

A/D Configuration: 128 ADEN SAMP Sample Div.: 0.5 sec

GPIO Controls: 0 pp0 IE1 OUT1 IN1

OpMode Controls: 2 OEO IE0 OUT0 IN0

S\$SLP Shelf POR sPOR

S\$SLP Div.: 0

Display Settings

Calculated Compensated Raw Decimal Binary Hex

A/D Control Registers

Regs Name	Enable	Resolution	Reference	Results	Settings	Actions	
Current (mA)	<input checked="" type="checkbox"/>	15 bit	Diff	-564.2	240	<input type="button" value="Update"/>	<input type="button" value="Read"/>
Int. Temp. (°C)	<input checked="" type="checkbox"/>	15 bit	S-E	29	249	<input type="button" value="Update"/>	<input type="button" value="Read"/>
Ext. Temp. (°C)	<input type="checkbox"/>	15 bit	S-E	N/A	122	<input type="button" value="Update"/>	<input type="button" value="Read"/>
VPack (mV)	<input checked="" type="checkbox"/>	15 bit	S-E	3483	251	<input type="button" value="Update"/>	<input type="button" value="Read"/>
GPAD (mV)	<input checked="" type="checkbox"/>	15 bit	S-E	11	253	<input type="button" value="Update"/>	<input type="button" value="Read"/>
Offset	<input type="checkbox"/>	15 bit		N/A	118	<input type="button" value="Update"/>	<input type="button" value="Read"/>

A/D Settings

RShnt: 20 mOhm SERef: 340 mV DiffRef: 170 mV

Loop Loop counter: 369

Voltage Measurement

The voltage measurement can be evaluated at the pack voltage and the GPAD voltage. Since the max input range of the A/D converter is 340mV, an internal voltage divider is provided to support up to 7V pack voltage measurement.

To request the pack voltage measurement, the A/D control register VPctrl must be enabled by checking the enable box for "VPack Volt". Specify the A/D conversion resolution, click "Update" and then "Read". The Pack voltage value will be displayed on the "Results" area.

Taking into account the internal voltage divider, the LSB value in a pack voltage measurement using the 340mV reference voltage is given by the following equation:

$$V_{\text{Pack LSB}} = \frac{10.2V}{2^{15}} = 311.3\mu V$$

The GPAD voltage measurement supports up to 6.2V. The 15-bit LSB value is:

$$GPAD \text{ LSB} = \frac{6.2V}{2^{15}} = 189.2\mu V$$

Internal Temperature Measurement

Temperature measurement using the internal temperature sensor can be performed by checking the enable box for "Int. Temp." Specify the A/D conversion resolution, click "Update" and then "Read." The internal temperature value will be displayed on the "Results" area.

The temperature measurement using the internal temperature sensor is derived using the following equation:

$$\text{Internal Temp} = \frac{ITres - 22761}{76.3} \quad (^\circ C)$$

Where ITres is the number of the A/D LSB counts at a 15-bit resolution. The ITres value can be requested by choosing "Raw" on the Display Settings area.

External Temperature Measurement

The NTC connection is provided at Pin 2 of the connector header J1. When the NTC function is enabled, the ISL6295 will source a 12.5μA current thru the NTC pin to the thermistor. To minimize power consumption, the reference output current from the NTC pin is not constantly ON, but periodically enabled when sampling is needed.

Since a thermistor has a negative temperature coefficient, the ISL6295 features an internal voltage inverter to translate the NTC voltage to a PTC voltage so that a larger A/D conversion result would correspond to a higher temperature reading. The actual voltage presented at the ADC input is:

$$V_{\text{ADC}} = V_{\text{REF}} - V_{\text{NTC}}$$

The reference voltage is 340mV for the external temperature measurement and the maximum NTC source current is 16μA. The dynamic range for the NTC input is from 0 to

340mV. Exceeding this dynamic range will result in an inaccurate temperature measurement. Hence it is important to choose a thermistor value such that the voltage does not exceed 340mV over the entire temperature range of interest. If the thermistor resistor value exceeds 340mV at low temperatures, a shunt resistor method, where a fixed resistor is placed in parallel with the thermistor, can be used. The parallel resistor reduces the overall resistance, particularly at the lower temperature range.

Figure 2 shows the dynamic ranges of the Semitec 103AT thermistor with and without the 24.9kΩ parallel resistor at minimum and maximum NTC source current. Without the parallel resistor, the NTC voltage will exceed 340mV at around +5°C at 16μA. With the parallel resistor the NTC voltage is below 340mV for down to -30°C at 16μA.

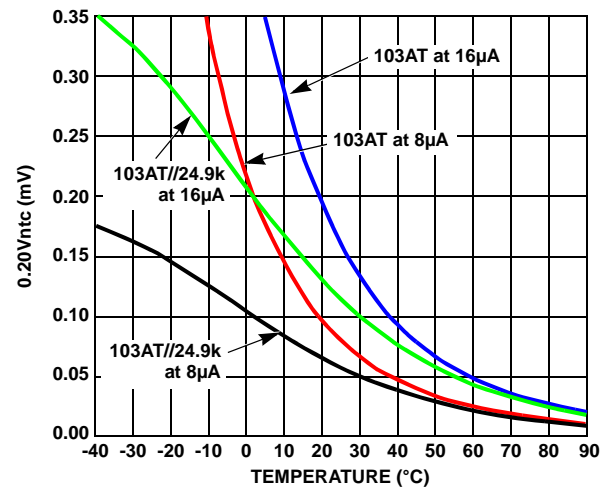

FIGURE 2. EXT TEMP MEASUREMENT WITH 103AT THERMISTOR AND PARALLEL RESISTOR

For temperature measurement using the external thermistor, check the enable box for "Ext. Temp." Specify the A/D conversion resolution, click "Update" and then "Read." The external temperature value will be displayed on the "Results" area.

For your convenience a Semitec 103AT thermistor is included in the evaluation kit. A look-up table is also provided for the 103AT thermistor and is located in C:\Program Files\Intersil Corp\ISL6295\ntclut.def. The table can be modified if needed using MS Word program. The table format is a single column of 10 entries. These entries list the thermistor resistance values correspond to a temperature range of -20°C to +70°C with a +10°C increment. The first entry is for -20°C and the last entry is for +70°C. If a parallel resistor is used, the entries should list the combined resistance of the thermistor and the resistor.

Offset Voltage Measurement

The ISL6295 incorporates a self-contained offset measurement as one of the input source selections for the A/D converter. When selected and enabled, the input of the A/D converter is internally shorted to the GND pin and an A/D conversion is performed. The result will be displayed on the "Results" area. Note this is only the IC offset, does not include the offset from the system. The evaluation boards have been factory calibrated to compensate the system offset.

Trip Controls/Accumulators Tab

The Trip Controls/Accumulators tab allows the user to switch the power modes of the ISL6295 and configure the accumulator functions.

Trip Control

The ISL6295 has five operational power modes: Power ON, Reset, Run, Sample, Sample-Sleep and Shelf-Sleep. The default mode after power on rest is Run mode. In the "Trip Control/TPV Registers" area, the user can specify the transition conditions from Run mode to the others. The Trip Point Values (TPV) are also entered in this area. For

example, if you'd like to switch from Run mode to Sample Sleep Mode by the pack voltage, enter a threshold value in the VCtrip box, for instance 3100mV. Click the "SET" button. Check the VCent box and click the "TRIP CTRL" button, then reduce the supply voltage at the VP pin to below 3100mV. The IC supply current will drop from 80μA to 20μA, indicating the operation has been switched to Sample-Sleep mode. Refer to Table 2 for the trip point value and the comparison registers.

TABLE 2. TRIP POINT VALUES

TPV REGISTER	LOCATION	COMPARISON REGISTER	ENABLE BIT
I+trip	60h	Ires	Iex
I-trip	64h	Ires	Ient
VPtrip	68h	VPres	VPex
VCtrip	6Ch	VPres or GPADres	VPent or GPADent
SStrip	70h	VPres	Shent

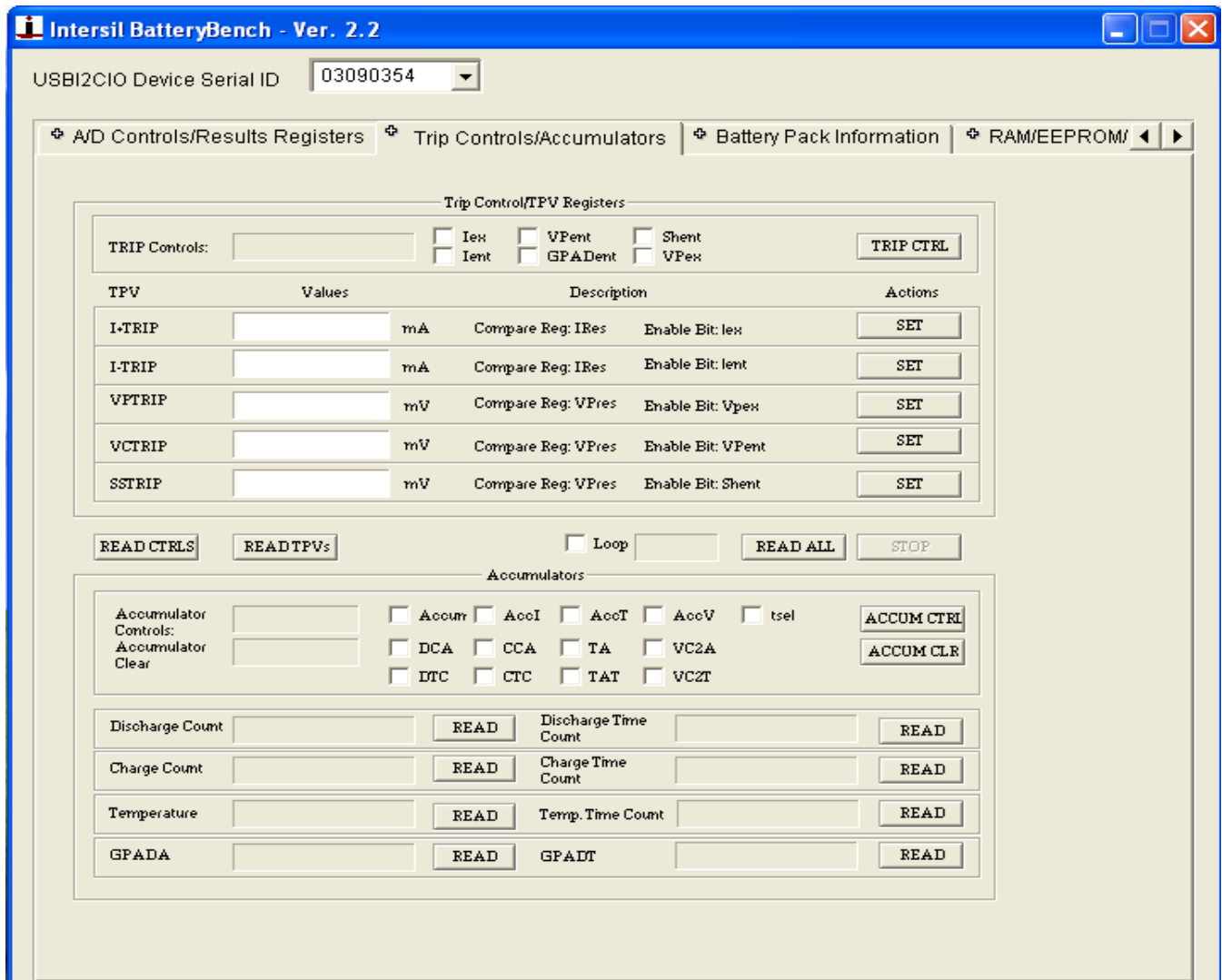

Accumulators

The Trip Controls/Accumulators tab allows the user to see the values or clear the values of the ISL6295 accumulators. To see the accumulator values, check the appropriate control names as listed in Table 3, and click the “ACCUM CTRL” tab. The current values will be displayed. To view the continuous update, check the “Loop” box and click the “READ ALL” button. To clear the value of an accumulator or counter, check the box next to the name of the accumulator or counter, and click the “ACCUM CLR” button.

TABLE 3. ACCUMULATOR CONTROL NAMES

Accum	Accumulator master enable
AccI	Current Accumulator enable
AccT	Temperature Accumulator enable
AccV	GPAD Voltage Accumulator Enable
Int Temp	Temperature Accumulation selection. Unchecked: for internal temp sensor Checked: for external temp sensor

The screenshot shows the Intersil BatteryBench software interface. The main window title is "Intersil BatteryBench - Ver. 2.2". At the top, the "USB2CIO Device Serial ID" is set to "03090354". Below this, there are four tabs: "Trip Controls/Accumulators", "Battery Pack Information", "RAM/EEPROM/LUT Contents", and "Fuel Gauging Driv". The "Trip Controls/Accumulators" tab is active.

The "Register/Memory Test" section includes:

- Addr (Hex): 0x9d
- Memory Bank: EE (bank0)
- Register/Memory Value: 9384
- Size: 2 bytes (selected)
- Format: Decimal (selected)
- Buttons: READ, WRITE, ReDisplay

The "EEPROM Contents" section displays a table with the following data:

Offset #	Contents							
	Byte 0	Byte 1	Byte 2	Byte 3	Byte 4	Byte 5	Byte 6	Byte 7
0x00	0	0	0	0	0	0	0	0
0x08	0	0	0	0	0	0	0	0
0x10	0	0	0	0	0	0	0	0
0x18	0	0	0	0	0	0	0	0
0x20	0	0	0	0	0	0	0	0
0x28	0	0	0	0	0	0	0	0
0x30	0	0	0	0	0	0	0	0

The "EODV/Residual Capacity LUT" section displays a table with the following data:

Description	C Rate	Temperature Ranges						
		Temp1	Temp2	Temp3	Temp4	Temp5	Temp6	Temp7
Temperature Axis	<= 0 (%C)	<= 0 (degC)	<= 0 (degC)	<= 0 (degC)	<= 0 (degC)	<= 0 (degC)	<= 0 (degC)	<= 0 (degC)
EODV @	<= 0 (%C)	0 (mV)	0 (mV)	0 (mV)	0 (mV)	0 (mV)	0 (mV)	0 (mV)
EODV @	<= 0 (%C)	0 (mV)	0 (mV)	0 (mV)	0 (mV)	0 (mV)	0 (mV)	0 (mV)
EODV @	<= 0 (%C)	0 (mV)	0 (mV)	0 (mV)	0 (mV)	0 (mV)	0 (mV)	0 (mV)
EODV @	> 0 (%C)	0 (mV)	0 (mV)	0 (mV)	0 (mV)	0 (mV)	0 (mV)	0 (mV)
Residual Capacity (CTP)		0 (mAh)	0 (mAh)	0 (mAh)	0 (mAh)	0 (mAh)	0 (mAh)	0 (mAh)

EEPROM/LUT Contents Tab

The EEPROM/LUT Contents tab gives the user access to all ISL6295 registers, volatile or non-volatile EEPROM memory locations. The EODV (end of discharge voltage) table for fuel gauge modeling is also provided on this page.

To read from a memory location, enter the address in the “addr” box in hex format, specify the memory bank number (refer to the memory map on the datasheet), specify the data length in number of byte (the program supports reading and writing 1, 2, or 4 bytes only), then click the “READ” button. The content will be displayed in a default decimal format. You may select Hex or Binary format in the “Format” area.

To write to a memory location, enter the value in the display box and click the “WRITE” button.

CAUTION: Some critical calibration and initialization data is programmed into the EEPROM locations with default values at the time of the ISL6295 manufacture. Any modification to these values may cause incorrect operation or malfunction of the part. Refer to Table 4 for the reserved locations.

TABLE 4. RESERVED EEPROM LOCATIONS

NAME	ADDRESS	NAME	ADDRESS
SMB Address	0x80	Pack Volt Gain	0x90, 0x91
Band Gap Trim	0x81	Freq Gain	0x92, 0x93
Volt Ref Trim	0x82	GPAD Gain	0x94, 0x95
Main OSC Trim	0x83	GPAD Offset	0x96
clkTM	0x84	Int Temp Gain	0x99, 0x9A
Test Mux	0x85	Int temp Offset	0x9B
Aux OSC Trim	0x86	Ext Temp Gain	0x9D, 0x9E
Current Gain	0x8D, 0x8E	Ext Temp Offset	0x9F
Current Offset	0x8F	-	-

Intersil BatteryBench - Ver. 2.2

USB2C10 Device Serial ID: 03090354

Trip Controls/Accumulators | **Battery Pack Information** | RAM/EEPROM/LUT Contents | Fuel Gauging Driv

Battery Pack Information

Field Name	Value	Field Name	Value	Field Name	Value
Serial Number	12345	Mfg Name	INTERSIL	Mfg Date	1980-0-0

Calibration/Testing Info

Pattern	512	Tester ID	3	Calibration Status	1
Current Gain	10000	VPack Gain	9209	GPAD Gain	10000
Current Offset	0	VPack Offset	0	GPAD Offset	0
Internal Temp. Offset	-5	External Temp. Gain	9384	Frequency Gain	10000

Fuel Gauge Driver Info

EOD Voltage (mV)	3100	EOC Voltage (mV)	4100	EOC Taper Curr (mA)	127
EOD Capacity (mAh)	100	Cycles	1	Fuel Gauging Setting	0xffff
Full Capacity (mAh)	600	Note: EOD - End of Discharge EOC - End of Charge			

Year: 2000
Month: 1
Day: 1

Buttons: Set Mfg Date, Write to EEPROM, Read from EEPROM, Import from DEF File, Export to DEF File, Import from LUT File, Export to LUT File

Battery Pack Information Tab

The Battery Pack Information tab allows the user to specify information necessary for fuel gauge operation. The information entered on this page includes: battery pack information, calibration information and the fuel gauge driver information.

Display the default setting first by clicking "Read from EEPROM". Make changes if necessary by overriding the fields (note some fields such as the Calibration/Testing Info, are read-only). If you would like to keep the updates permanently, click the "Write to EEPROM" button.

The Battery Pack Information section allows the user to record the serial number, the manufacturer's name and the manufacture date. Enter the manufacturing date in the drop down boxes and click "Set Mfg Date".

The Calibration/Testing section provides the calibration information for the critical parameters such as voltage, current, frequency and temperature. The calibration constants displayed here have been pre-programmed by

Intersil and are read-only. These calibration factors will be used during the fuel gauging calculation.

The Fuel Gauge Driver Info section allows the user to enter fuel gauge related battery information such as EOC voltage, EOD voltage, EOC current, etc. (Note that a valid EOC Taper Current entry is between 10mA and 255mA). Changes will not take effect until user clicks "Write to EEPROM".

Setting EOD voltage to a non-zero value will override the EODV lookup table value. Since the fully charged condition is qualified when both the EOC voltage and the EOC taper current are met, these values must be set to some realistic numbers to qualify a fully charge condition. Typical values are 4.1V for EOC voltage and 100mA for EOC taper current.

Fuel Gauging Driver Tab

The Fuel Gauging Driver tab provides user the opportunity to perform a high accuracy calculation of the remaining cell capacity using the Intersil's fuel gauging algorithm.

Application Note 1174

ISL6295EVAL1 BILL OF MATERIALS

ITEM	QTY	REFERENCE	PART DESCRIPTION	PCB FOOTPRINT	PART NUMBER	VENDOR
1	1	U1	ISL6295 fuel gauge IC	8L-TSSOP	ISL6295CV	Intersil
2	1	U2	Single cell protection IC	SOT-26A	MM3077DNRE	Mitsumi
3	1	Q1	Dual N-CH MOSFET, 20V, 20mΩ	8L-TSSOP	Si6880EDQ	Siliconix
4	2	R6, R7	SMD resistor, 680Ω, 1/16W	0402	ERJ-2RKF6810X	Panasonic
5	2	R1, R2	SMD resistor, 1.0k, 1/16W	0402	ERJ-2RKF1001X	Panasonic
6	1	R4	SMD resistor, 221k, 1%, 1/16W	0402	ERJ-2RKF2213X	Panasonic
7	1	R5	Sensor resistor, 20mΩ, 1% 1/4W	1206	WSL1206	Vishay
8	3	C1, C2, C4	Ceramic cap, 100nF, 10V, X7R	0402	ECJ-0EB1A104K	Panasonic
9	1	C3	Ceramic cap, 1.0nF, 25V, X7R	0402	ECJ-0EB1E102K	Panasonic
10	2	D1, D2	Zener diode, 5.6V	SOD523	BZX585-C5V6	Phillips
11	1	PCB	FR4, 0.062", 1 OZ copper	-	ED130/4DS	Any
12	8	TP1 to TP8	Test pin, 37 mil Dia. 0.4" height	-	0300-2-15-01-47-27-10-0	Mill Max
13	4	JP1 to JP4	2.54mm header, 2CKT	-	22-28-4020	Molex
14	1	J1	2.54mm center header, 5CKT	-	22-11-2052	Molex
15	1	J2	2.54mm center header, 3CKT	-	22-11-2032	Molex
-	1	Mate to J2	2.54mm terminal housing, 3CKT	-	22-01-3037	Molex
16	1	J3	2.54mm center header, 2CKT	-	22-11-2022	Molex
17	4	-	Pumpon, 0.44X0.2, black	-	SJ-5303	3M/ESM

PCB Layout

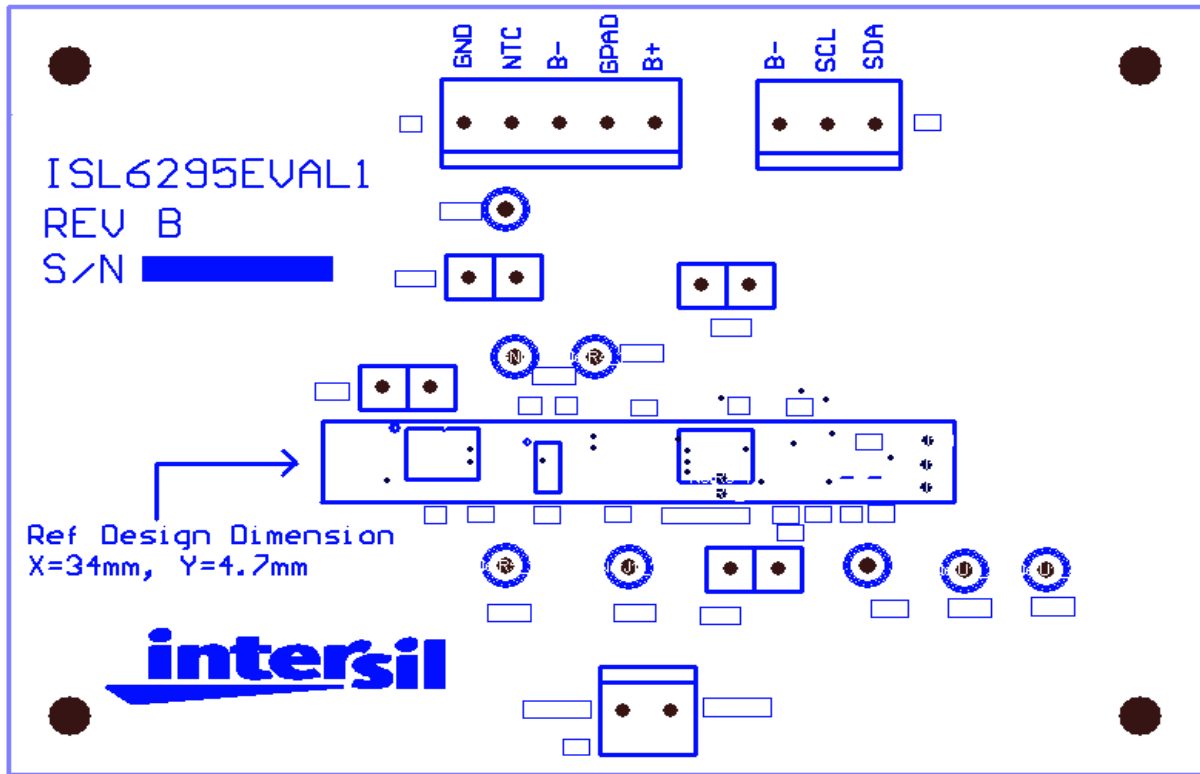

FIGURE 4. SILK LAYER

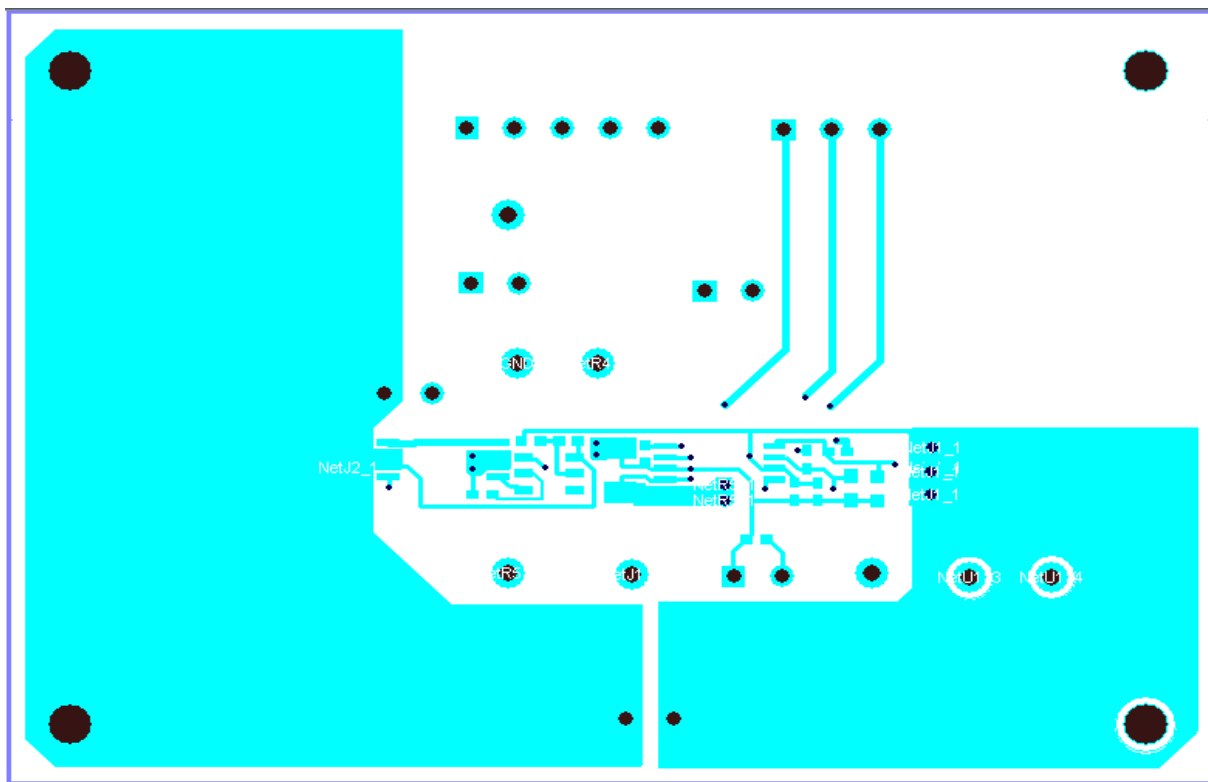

FIGURE 5. TOP LAYER

PCB Layout (Continued)

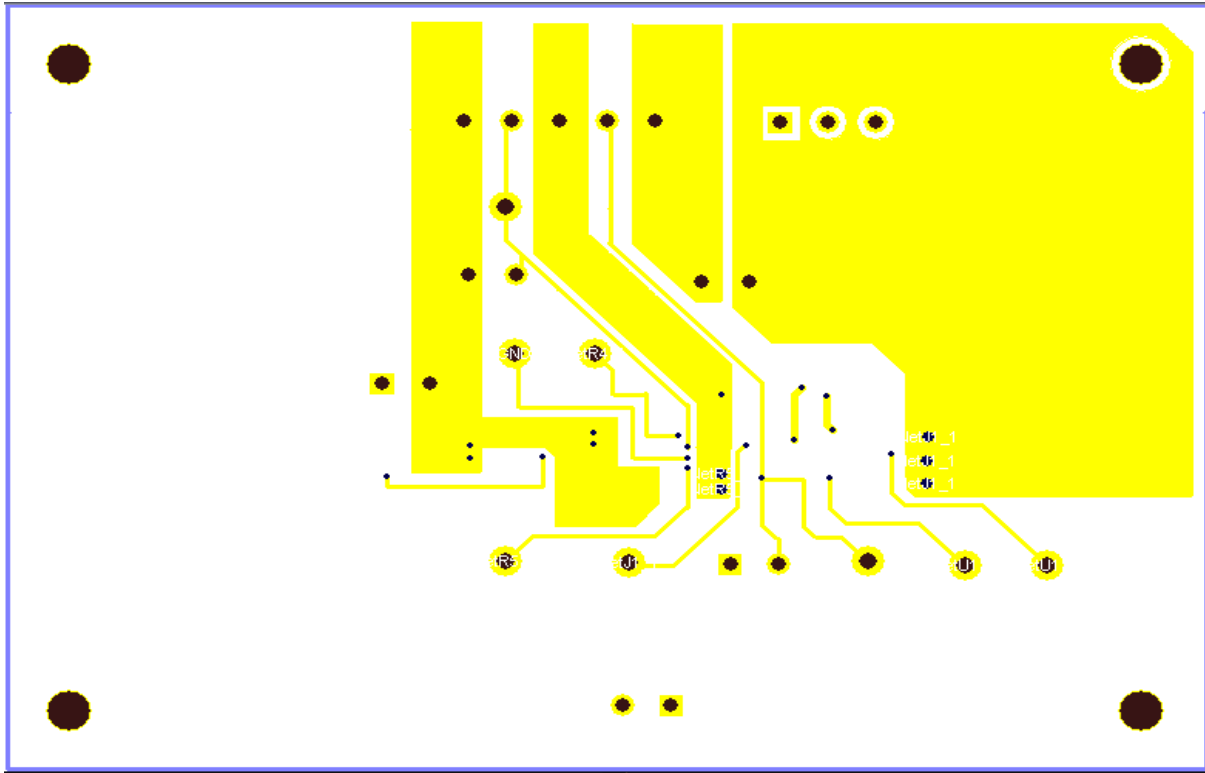

FIGURE 6. BOTTOM LAYER

All Intersil U.S. products are manufactured, assembled and tested utilizing ISO9000 quality systems.
Intersil Corporation's quality certifications can be viewed at www.intersil.com/design/quality

Intersil products are sold by description only. Intersil Corporation reserves the right to make changes in circuit design, software and/or specifications at any time without notice. Accordingly, the reader is cautioned to verify that data sheets are current before placing orders. Information furnished by Intersil is believed to be accurate and reliable. However, no responsibility is assumed by Intersil or its subsidiaries for its use; nor for any infringements of patents or other rights of third parties which may result from its use. No license is granted by implication or otherwise under any patent or patent rights of Intersil or its subsidiaries.

For information regarding Intersil Corporation and its products, see www.intersil.com