

D2-41x51 DAE-4 Intelligent Digital Amplifier PWM Controller and Audio Processor

D2-41051, D2-41151 DAE-4 IC Devices

The D2-41051 and D2-41151 (D2-41x51) devices are complete System-on-Chip (SoC) Audio Processor and Class-D Amplifier Controllers, offering a powerful yet very cost effective audio solution for high volume consumer products, including Digital TV systems, PC Multimedia Speakers, and Portable Device Docking Stations. This 4th generation Digital Audio Engine (DAE-4) device combines extensive integrated DSP processing and configurable audio processing algorithms, for complete audio system control. The D2-41x51 devices are built upon the proven technology present in D2Audio's D2-814xx, D2-914xx, and D2-926xx families of Class-D Controller ICs, while providing an optimized feature set for high volume and cost-critical products.

The D2Audio D2-41x51 devices offer the optimum balance of functionality and lowest system material cost, especially in a SoC system architectures with I²S audio output. All audio processing and amplifier control is handled by the D2-41x51, and its ease of integration to the existing system processor handles all system control functions.

Features

- DAE-4 Controller IC
- All Digital Class-D Amplifier Controller with Integrated Digital Signal Processing (DSP)
- Up to 5 Channels of Digital Signal Processing (DSP)
- Fully Programmable Audio Signal Path Parameters
- Includes Equalizers, Filters, Mixers and Other Common Audio Processing Blocks
- Digital Loudspeaker Correction and Optimization
- Asynchronous Sample Rate Converters, Sample Rates from 32kHz up to 192kHz
- Supports 2.0, 2.1 or Bi-Amp Amplifier Outputs with Discrete or Integrated Power Stages
- SoundSuite™ Immersive Processing Software
- 3rd Party Support: SRS WOW/HD™
- I²C Host Control Port
- 48-Lead QFN Package

Applications

- iPod Docking Stations
- Stereo Multimedia Speakers With Separate Powered Subwoofer
- Installed-Home Wall Amplifiers
- High-End DTV

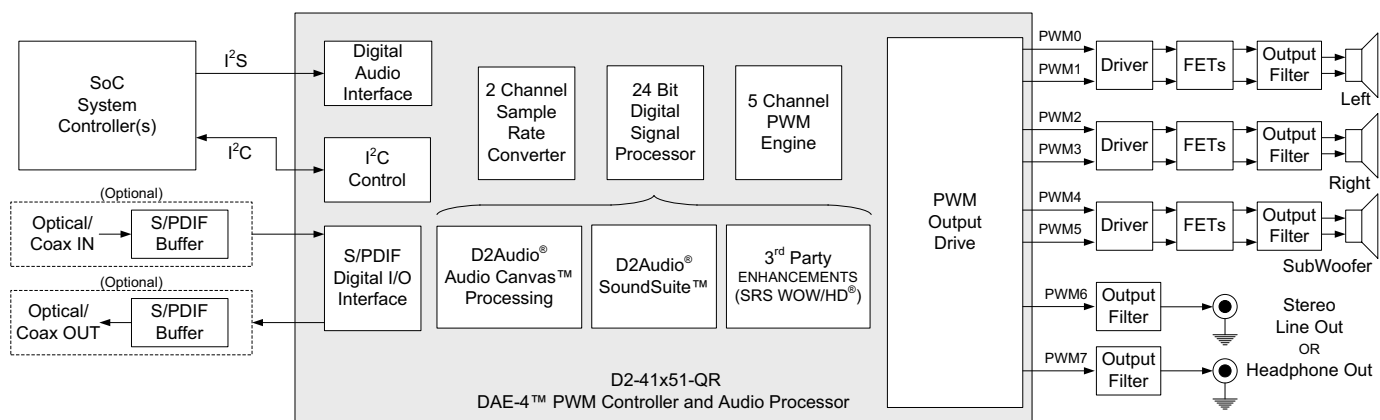

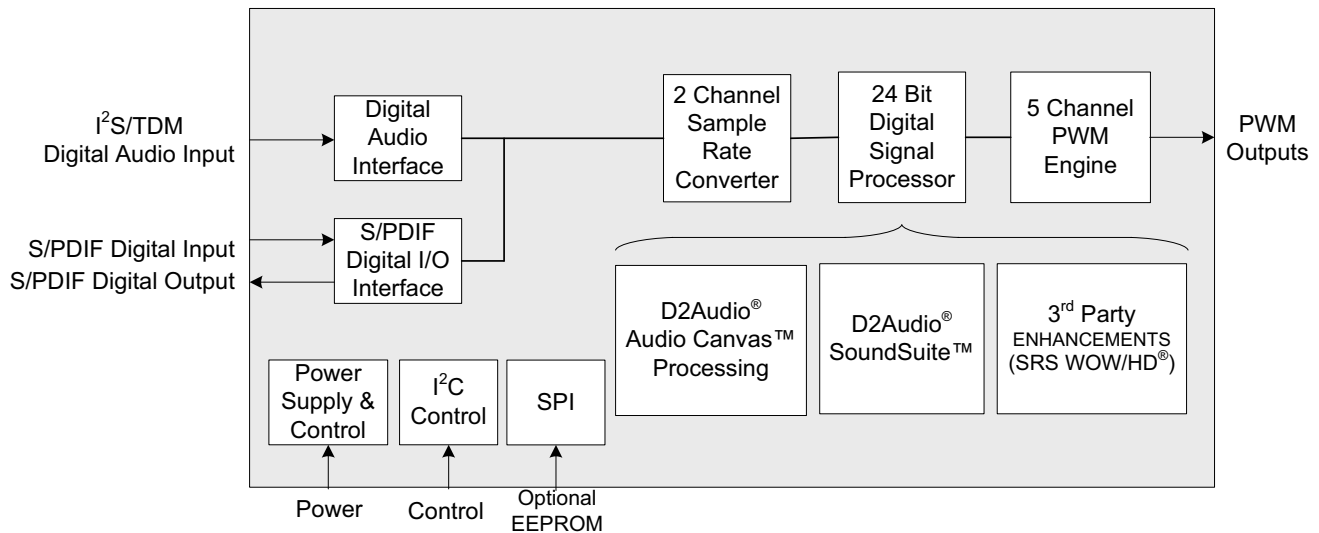

Functional Overview

The D2-41x51 devices are integrated System-on-Chip (SoC) audio processor and Class D amplifier PWM controller. They include complete digital audio input selection, signal routing, complete audio processing, and selectable PWM output options for driving multiple output power stage configurations. Stereo I²S and stereo S/PDIF digital input support, plus I²C and 2-wire SPI control interfaces enable integration compatibility with existing system architectures and solutions. The audio path includes a stereo Sample Rate Converter (SRC) plus device-specific audio enhancement processing algorithms.

An I²C Host Control Port, and Stereo I²S Digital inputs allows seamless integration to existing system architectures and product solutions. The Digital Audio inputs are processed by a stereo Sample Rate Converter (SRC) that feeds a 5-channel PWM engine. The 5 integrated audio processing paths and PWM output controllers provide drive for flexible audio outputs, including Stereo Speakers, 2.1 Speaker and Stereo Bi-Amp Speaker solutions, as well as Stereo Line or Headphone Outputs, and a Subwoofer Line Output. The flexible output configuration supports Full-Bridge, Half-Bridge and Bridge-Tied-Load (BTL) output stage topologies, with either discrete or integrated output stages.

Fully configurable and routable audio signal parameters and signal flow are supported by Audio Canvas™ software. Audio flow and processing options are easily modified in production, allowing multiple product models to be configured with a single audio system architecture. In addition to the independent 5-band-per-channel equalizers, tone controls, Dynamic Range Compression (DRC), and volume controls, the D2-41x51-QR supports the D2Audio SoundSuite™ (WideSound™, DeepBass™, DigitalEQ™, ClearVoice™) enhancements, plus 3rd-Party enhancements including SRS WOW/HD™.

Audio Enhancement Feature Processing

Additional enhancement audio processing algorithms are included within specific part number options of the D2-41x51 devices. These specific enhancements are:

- D2Audio™ SoundSuite™ (WideSound™, DeepBass™, Audio Align™, and ClearVoice™) Audio Processing (with the D2-41051 device)
- SRS WOW/HD™ (with the D2-41151 device)

intersil®

www.intersil.com

1001 Murphy Ranch Road
Milpitas, CA 95035

North America 1-888-INTERSIL (1-888-468-3774)
International (01) 321-724-7143